

Silicon N-Channel MOSFET

Features

- 9A, 200V, $R_{DS(on)}$ (Max 0.4 Ω)@ $V_{GS}=10V$
- Ultra-low Gate Charge(Typical 43nC)
- Fast Switching Capability
- 100%Avalanche Tested
- Maximum Junction Temperature Range(150°C)

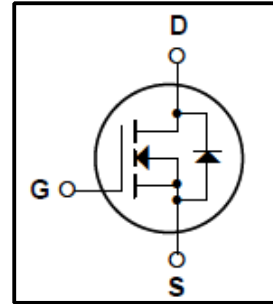

General Description

This Power MOSFET is produced using Winsemi's advanced planar stripe, DMOS technology. This latest technology has been especially designed to minimize on-state resistance, have a high rugged avalanche characteristics. This devices is specially well suited for low voltage applications such as automotive, high efficiency switching for DC/DC converters, and DC motor control.

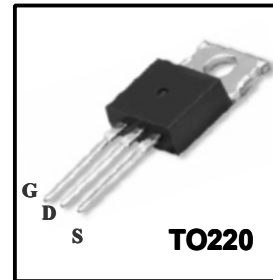

Absolute Maximum Ratings

Symbol	Parameter	Value	Units
V_{DSS}	Drain Source Voltage	200	V
I_D	Continuous Drain Current(@ $T_c=25^\circ C$)	9	A
	Continuous Drain Current(@ $T_c=100^\circ C$)	5.7	A
I_{DM}	Drain Current Pulsed (Note1)	36	A
V_{GS}	Gate to Source Voltage	± 30	V
E_{AS}	Single Pulsed Avalanche Energy (Note 2)	160	mJ
E_{AR}	Repetitive Avalanche Energy (Note 1)	7.2	mJ
dv/dt	Peak Diode Recovery dv/dt (Note 3)	5.5	V/ns
P_D	Total Power Dissipation(@ $T_c=25^\circ C$)	72	W
	Derating Factor above 25°C	0.57	W/°C
T_J, T_{stg}	Junction and Storage Temperature	-55~150	°C
T_L	Maximum lead Temperature for soldering purposes	300	°C

Thermal Characteristics

Symbol	Parameter	Value			Units
		Min	Typ	Max	
R_{QJC}	Thermal Resistance, Junction-to-Case	-	-	1.74	°C/W
R_{QCS}	Thermal Resistance, Case to Sink	-	0.5	-	°C/W
R_{QJA}	Thermal Resistance, Junction-to-Ambient	-	-	62.5	°C/W

Electrical Characteristics (Tc = 25°C)

Characteristics	Symbol	Test Condition	Min	Type	Max	Unit	
Gate leakage current	I _{GSS}	V _{GS} = ±30 V, V _{DS} = 0 V	-	-	±100	nA	
Gate-source breakdown voltage	V _{(BR)GSS}	I _G = ±10 μA, V _{DS} = 0 V	±30	-	-	V	
Drain cut-off current	I _{DSS}	V _{DS} = 200 V, V _{GS} = 0 V	-	-	10	μA	
Drain-source breakdown voltage	V _{(BR)DSS}	I _D = 250 μA, V _{GS} = 0 V	200	-	-	V	
Break Voltage Temperature Coefficient	$\frac{\Delta BV_{DSS}}{\Delta T_J}$	I _D =250μA, Referenced to 25°C	-	0.2	-	V/°C	
Gate threshold voltage	V _{GS(th)}	V _{DS} = 10 V, I _D =250 μA	2	-	4	V	
Drain-source ON resistance	R _{DS(ON)}	V _{GS} = 10 V, I _D = 5.4A	-	-	0.4	Ω	
Forward Transconductance	g _{fs}	V _{DS} = 50 V, I _D =5.4A	3.8	-	-	S	
Input capacitance	C _{iss}	V _{DS} = 25 V,	-	800	-	pF	
Reverse transfer capacitance	C _{rss}	V _{GS} = 0 V,	-	76	-		
Output capacitance	C _{oss}	f = 1 MHz	-	240	-		
Switching time	Rise time	t _r	V _{DD} =100 V,	-	9.4	-	ns
	Turn-on time	t _{on}	I _D = 5.9 A	-	28	-	
	Fall time	t _f	R _G =12 Ω	-	39	-	
	Turn-off time	t _{off}	(Note4,5)	-	20	-	
Total gate charge (gate-source plus gate-drain)	Q _g	V _{DD} = 160 V,	-	43	-	nC	
Gate-source charge	Q _{gs}	V _{GS} = 10 V,	-	7	-		
Gate-drain ("miller") Charge	Q _{gd}	I _D = 5.9 A (Note4,5)	-	23	-		

Source-Drain Ratings and Characteristics (Ta = 25°C)

Characteristics	Symbol	Test Condition	Min	Type	Max	Unit
Continuous drain reverse current	I _{DR}	-	-	-	9	A
Pulse drain reverse current	I _{DRP}	-	-	-	36	A
Forward voltage (diode)	V _{DSF}	I _{DR} = 9 A, V _{GS} = 0 V	-	1.4	2.0	V
Reverse recovery time	t _{rr}	I _{DR} = 5.9A, V _{GS} = 0 V,	-	170	340	ns
Reverse recovery charge	Q _{rr}	dI _{DR} / dt = 100 A / μs	-	1.1	2.2	μC

- Note 1.Repeativity rating :pulse width limited by junction temperature
 2.L=500uH,I_{AS}=9 A,V_{DD}=50V,R_G=0Ω,Starting T_J=25°C
 3.I_{SD}≤9A,di/dt≤300A/us, V_{DD}<BV_{DSS},STARTING T_J=25°C
 4.Pulse Test: Pulse Width≤300us,Duty Cycle≤2%
 5.Essentially independent of operating temperature.

This transistor is an electrostatic sensitive device
 Please handle with caution

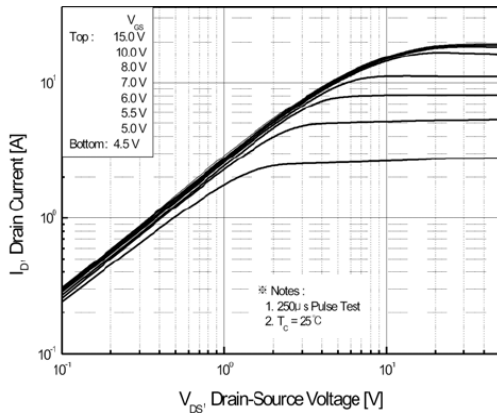

Fig. 1 On-State Characteristics

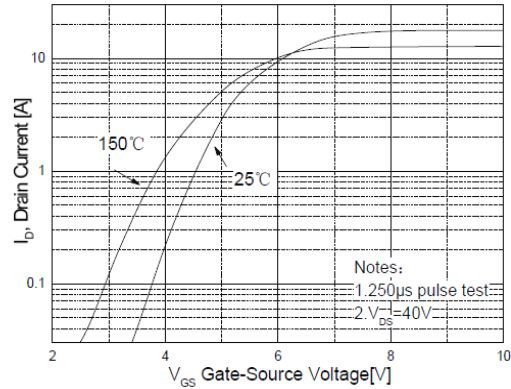

Fig. 2 Transfer Characteristics

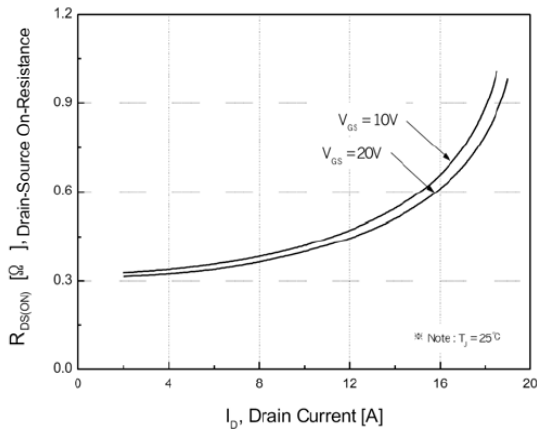

Fig. 3 On-Resistance Variation vs Drain Current

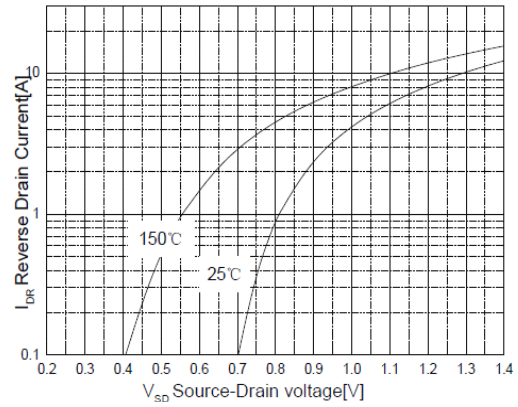

Fig. 4 Body Diode Forward Voltage Variation vs. Source Current and Temperature

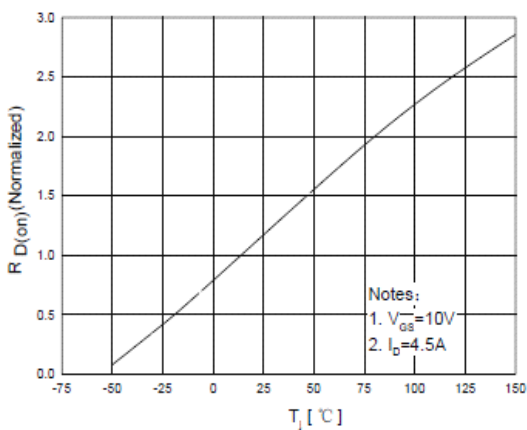

Fig. 5 On-Resistance Variation vs Junction Temperature

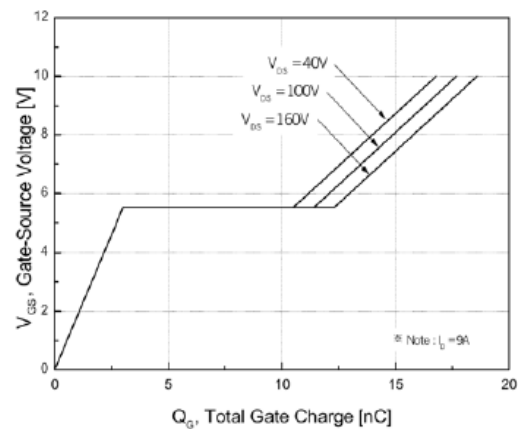

Fig. 6 Gate Charge Characteristics

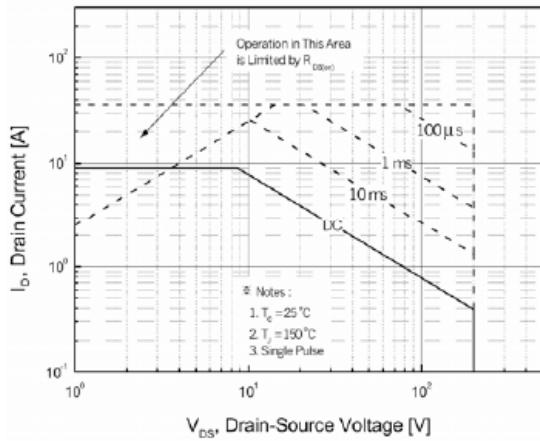

Fig.7 Maximum Safe Operation Area

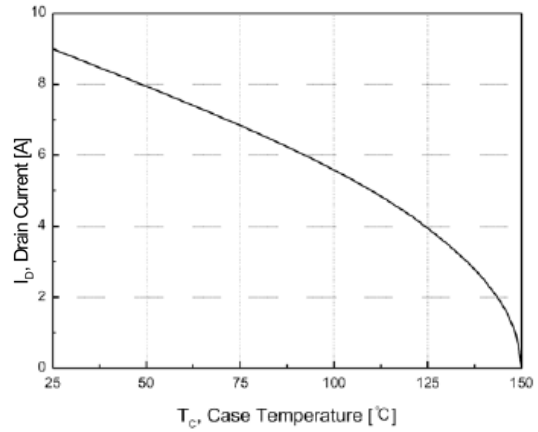

Fig.8 Maximum Drain Current vs Case Temperature

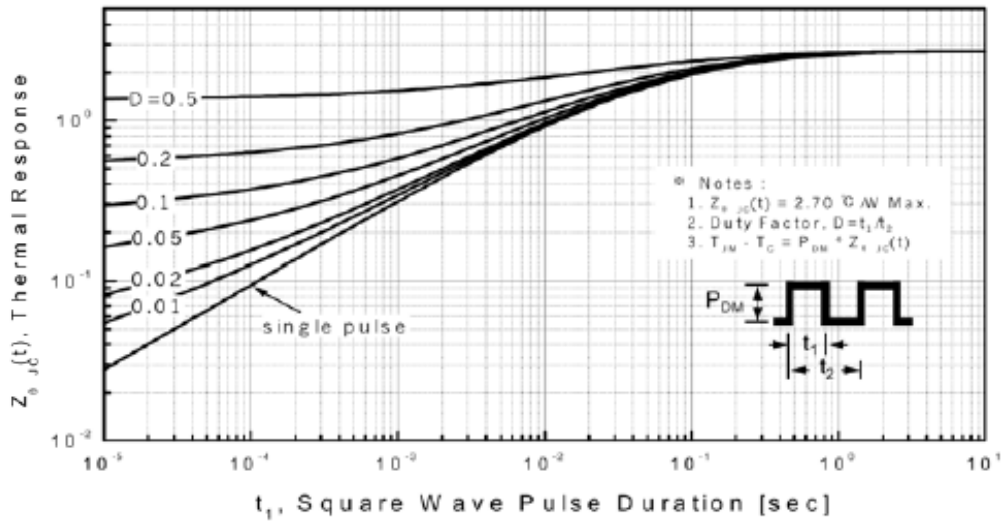

Fig.9 Transient Thermal Response Curve

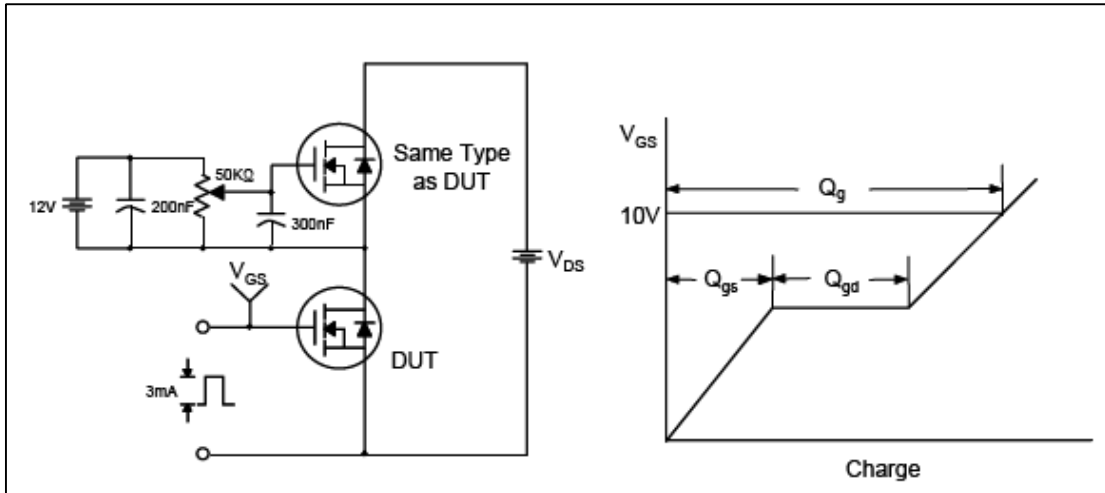

Fig.10 Gate Test Circuit & Waveform

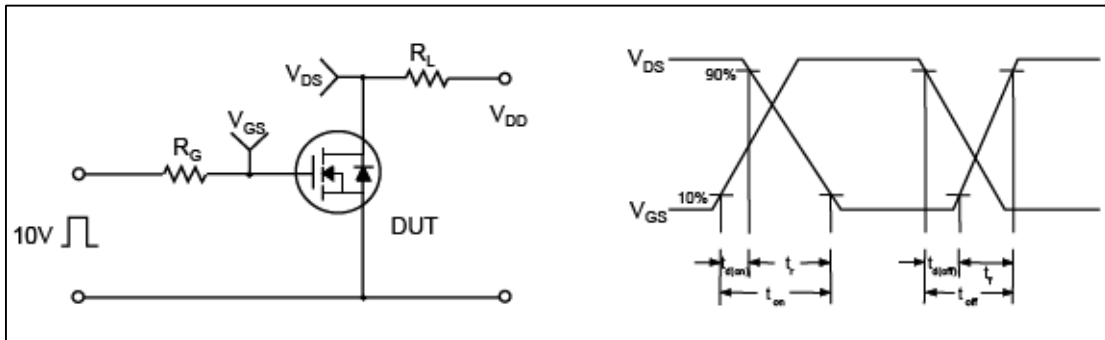

Fig.11 Resistive Switching Test Circuit & Waveform

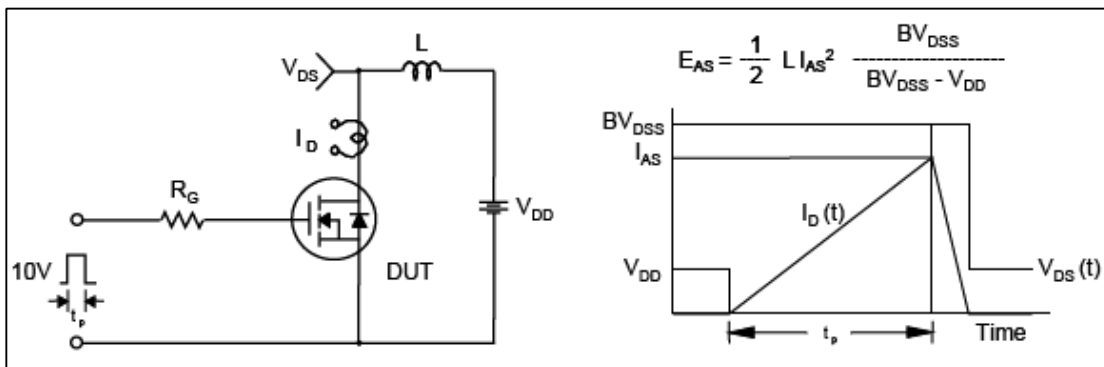

Fig.12 Unclamped Inductive Switching Test Circuit & Waveform

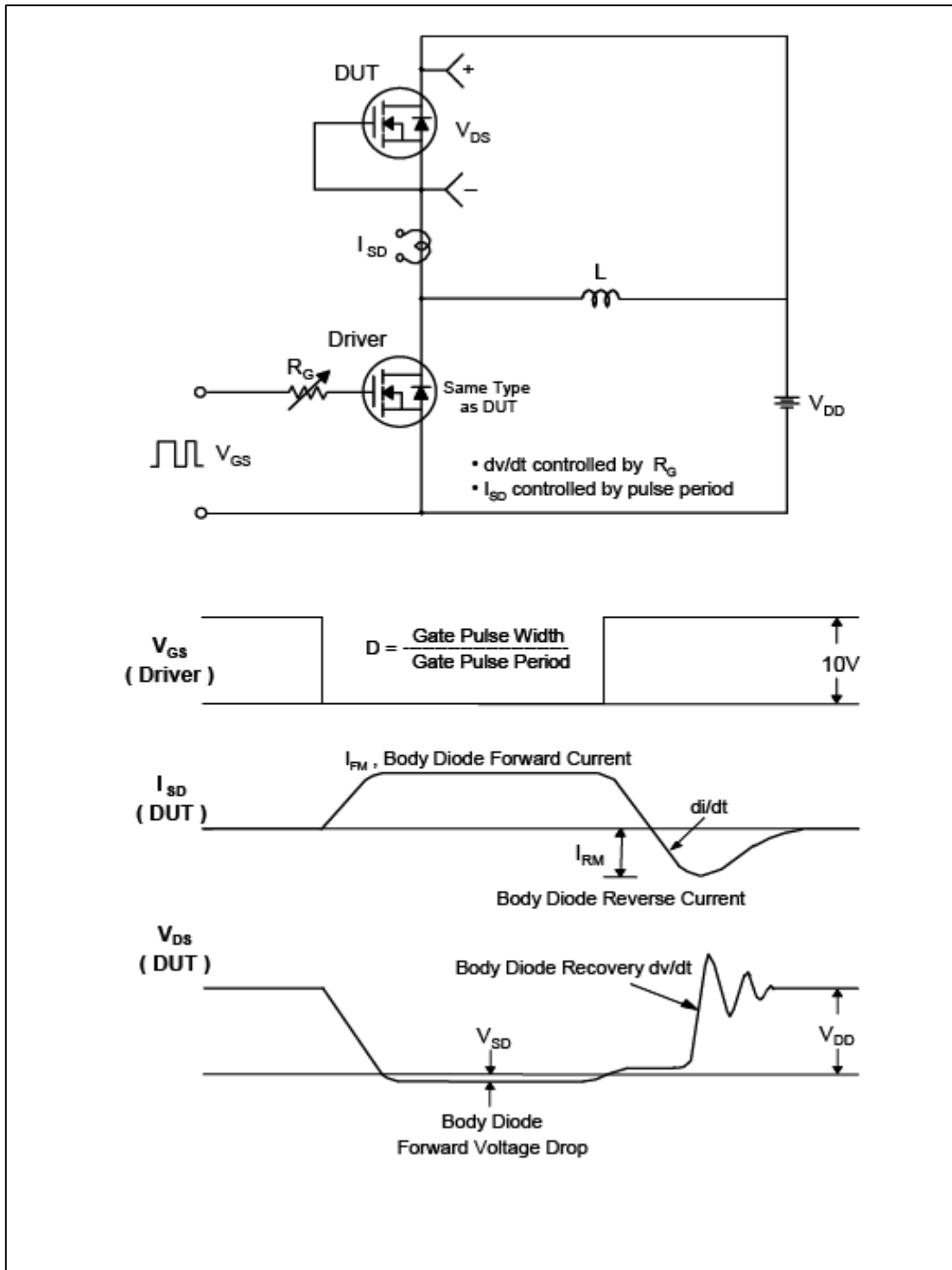

Fig.13 Peak Diode Recovery dv/dt Test Circuit & Waveform

TO-220 Package Dimension

