

Silicon N-Channel MOSFET

Features

- 59A,100V, $R_{DS(on)}$ (Max 18m Ω)@ $V_{GS}=10V$
- Ultra-low Gate Charge(Typical 1180nC)
- Fast Switching Capability
- 100%Avalanche Tested
- Maximum Junction Temperature Range(175 $^{\circ}C$)

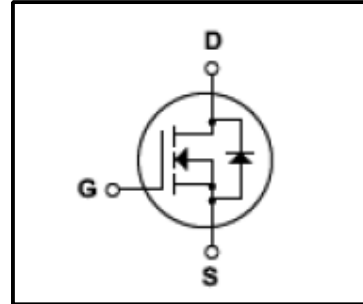

General Description

This Power MOSFET is produced using Winsemi's advanced planar stripe,DMOS technology. This latest technology has been especially designed to minimize on -state resistance,have a high rugged avalanche characteristics. This devices is specially well suited for switching regulators, switching convertors, motor and relay drivers , and drivers for high power bipolar switching transistor demanding high speed and low gate drive power.

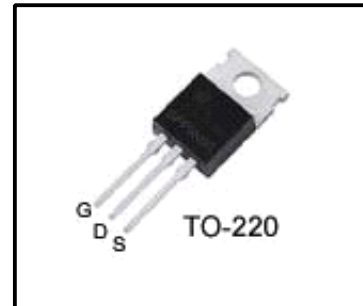

Absolute Maximum Ratings

Symbol	Parameter	Value	Units
V_{DSS}	Drain Source Voltage	100	V
I_D	Continuous Drain Current(@ $T_c=25^{\circ}C$)	59	A
	Continuous Drain Current(@ $T_c=100^{\circ}C$)	42	A
I_{DM}	Drain Current Pulsed (Note1)	240	A
V_{GS}	Gate to Source Voltage	± 20	V
E_{AS}	Single Pulsed Avalanche Energy (Note2)	170	mJ
E_{AR}	Repetitive Avalanche Energy (Note1)	7.4	mJ
dv/dt	Peak Diode Recovery dv /dt (Note3)	5.8	V/ ns
P_D	Total Power Dissipation(@ $T_c=25^{\circ}C$)	136	W
	Derating Factor above 25 $^{\circ}C$	1.3	W/ $^{\circ}C$
T_J, T_{stg}	Junction and Storage Temperature	-55~150	$^{\circ}C$
T_L	Maximum lead Temperature for soldering purposes	300	$^{\circ}C$

Thermal Characteristics

Symbol	Parameter	Value			Units
		Min	Typ	Max	
R_{QJC}	Thermal Resistance , Junction -to -Case	-	-	0.92	$^{\circ}C/W$
R_{QCS}	Thermal Resistance , Case-to-Sink	-	0.5	-	$^{\circ}C/W$
R_{QJA}	Thermal Resistance , Junction-to -Ambient	-	-	62.5	$^{\circ}C/W$

Electrical Characteristics(Tc=25°C)

Characteristics	Symbol	Test Condition	Min	Type	Max	Unit	
Gate leakage current	I _{GSS}	V _{GS} =±20V,V _{DS} =0V	-	-	±100	nA	
Gate-source breakdown voltage	V _{(BR)GSS}	I _G =±10 μA,V _{DS} =0V	±30	-	-	V	
Drain cut -off current	I _{DSS}	V _{DS} =100V,V _{GS} =0V	-	-	20	μA	
Drain -source breakdown voltage	V _{(BR)DSS}	I _D =250 μA,V _{GS} =0V	100	-	-	V	
Break voltage Temperature Coefficient	ΔBV _{DSS} / ΔT _J	I _D =1mA, Referenced to 25°C	-	0.1	-	V/°C	
Gate threshold voltage	V _{GS(th)}	V _{DS} =10V,I _D =250 μA	2	-	4	V	
Drain -source ON resistance	R _{DS(ON)}	V _{GS} =10V,I _D =35A	-	-	18	mΩ	
Forward Transconductance	g _{fs}	V _{DS} =50V,I _D =35A	-	35	-	S	
Input capacitance	C _{iss}	V _{DS} =25V,	-	2990	-	pF	
Reverse transfer capacitance	C _{rss}	V _{GS} =0V,	-	160	-		
Output capacitance	C _{oss}	f=1MHz	-	3000	-		
Switching time	Rise time	t _r	V _{DD} =28V,	-	18	-	ns
	Turn-on time	t _{on}	I _D =75A,	-	86	-	
	Fall time	t _f	R _G =6.8Ω,	-	47	-	
	Turn-off time	t _{off}	(Note4,5)	-	60	-	
Total gate charge(gate-source plus gate-drain)	Q _g	V _{DD} =80V, V _{GS} =10V,	-	1180	-	nC	
Gate-source charge	Q _{gs}	I _D =35A	-	190	-		
Gate-drain("miller") Charge	Q _{gd}	(Note4,5)	-	300	-		

Source-Drain Ratings and Characteristics(Ta=25°C)

Characteristics	Symbol	Test Condition	Min	Type	Max	Unit
Continuous drain reverse current	I _{DR}	-	-	-	59	A
Pulse drain reverse current	I _{DRP}	-	-	-	240	A
Forward voltage(diode)	V _{DSF}	I _S =35A,V _{GS} =0V	-	-	1.5	V
Reverse recovery time	t _{rr}	I _{DR} =75A,V _{DD} =25V,	-	56	75	ns
Reverse recovery charge	Q _{rr}	dI _{DR} / dt =100 A / μs	-	106	160	μC

Note 1.Repeativity rating :pulse width limited by junction temperature

2.L=50μH I_{AS}=59A,V_{DD}=50V,R_G=25Ω ,Starting T_J=25°C

3.I_{SD}≤59A,di/dt≤300A/us,V_{DD}<BV_{DSS},STARTING T_J=25°C

4.Pulse Test:Pulse Width≤300us,Duty Cycle≤2%

5. Essentially independent of operating temperature.

This transistor is an electrostatic sensitive device

Please handle with caution

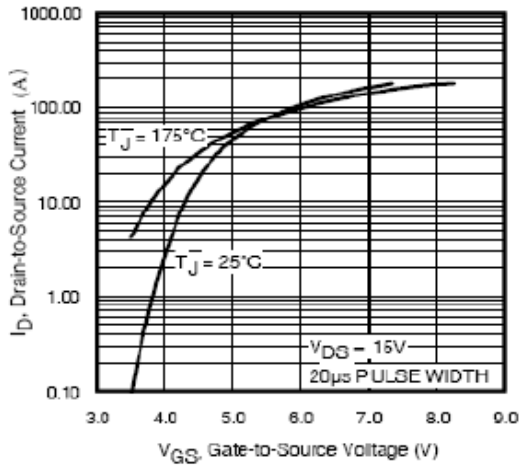

Fig.1 On -State Characteristics

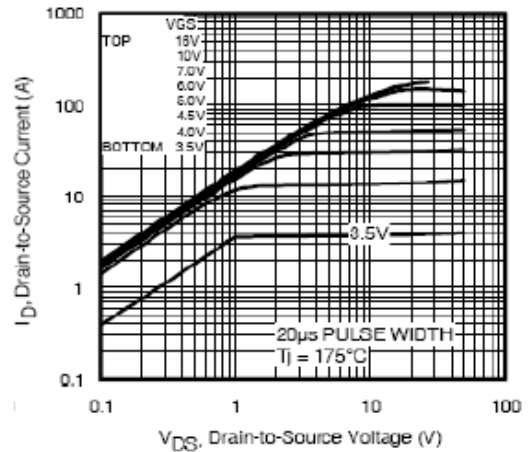

Fig.2 Typical Output Characteristics

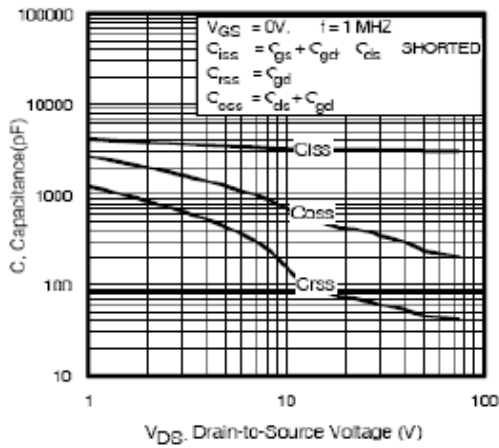

Fig.3 Typical Capacitance vs Drain Current

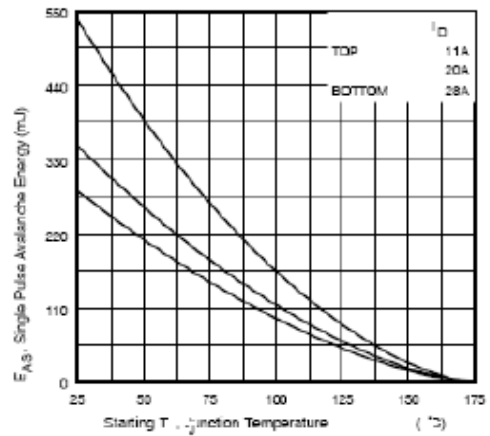

Fig.4 Maximum Avalanche Energy vs Drain Current

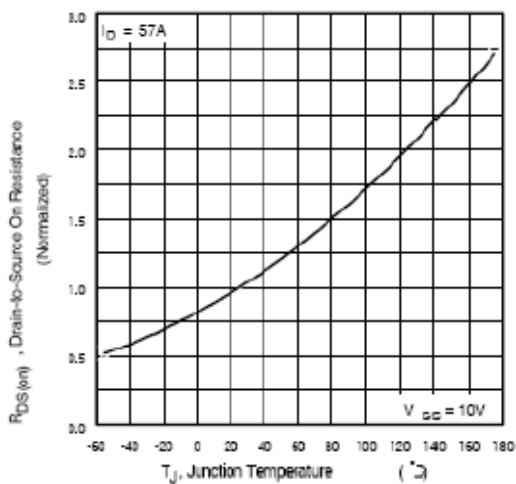

Fig.5 On-Resistance Variation vs Junction Temperature

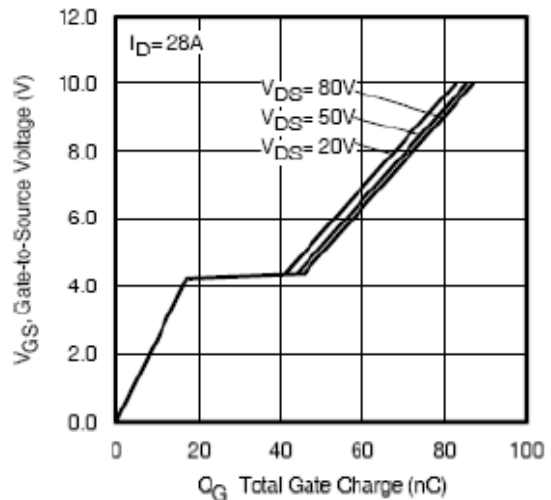

Fig.6 Gate charge Characteristics

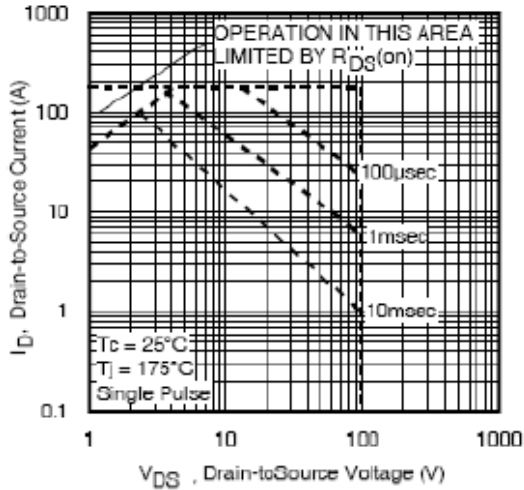

Fig.7 Maximum Safe Operation Area

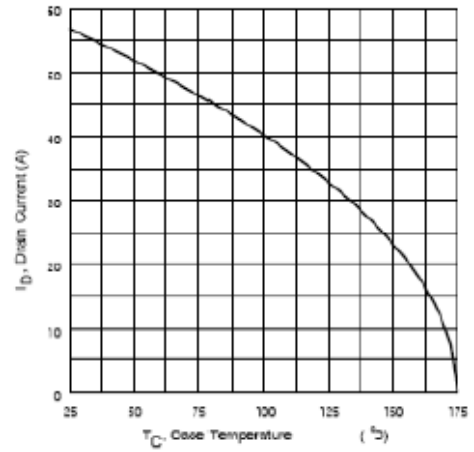

Fig.8 Maximum Drain current vs Case Temperature

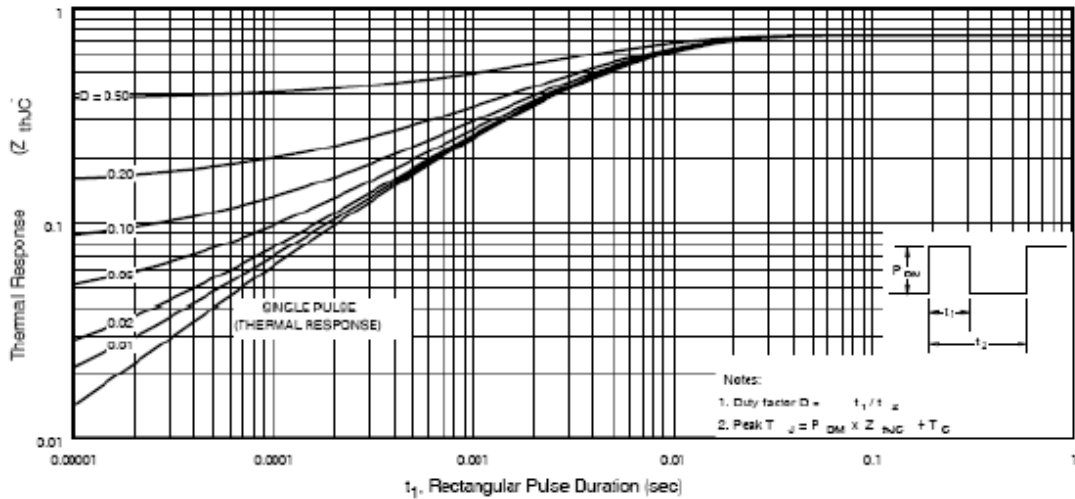

Fig.9 Transient Thermal Response Curve

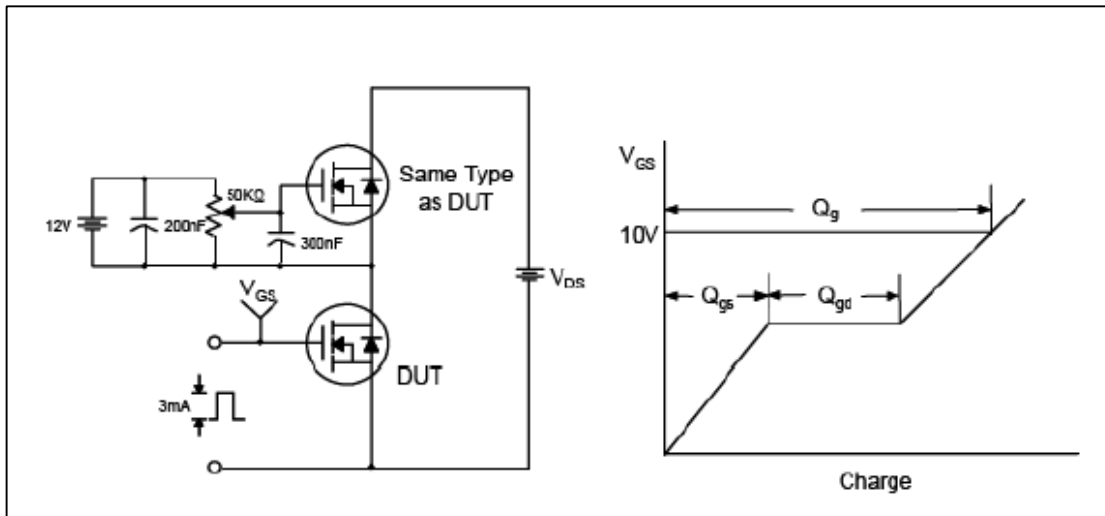

Fig.10 Gate Test circuit & Waveform

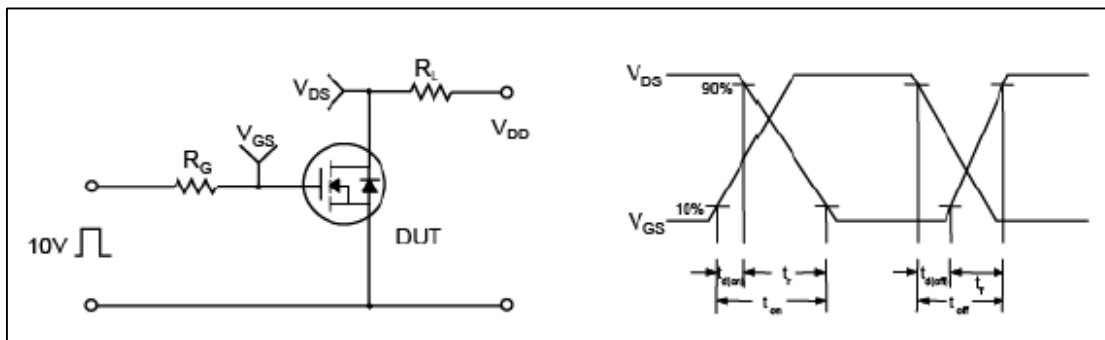

Fig.11 Resistive Switching Test Circuit & Waveform

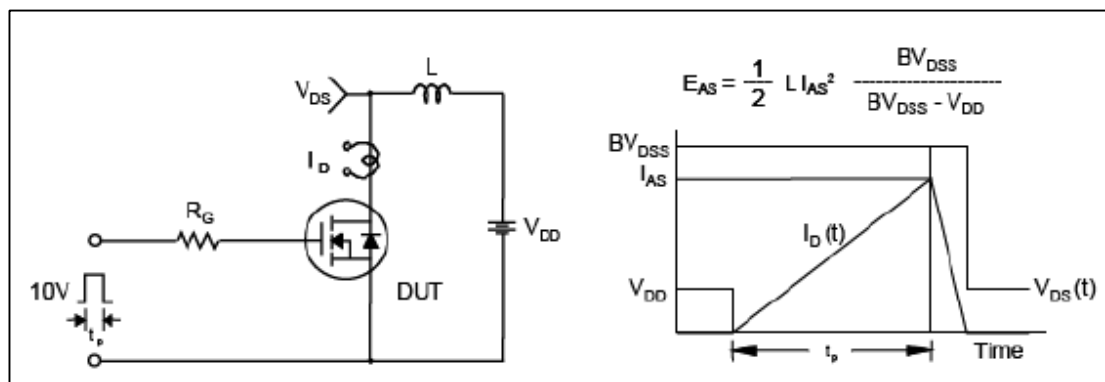

Fig.12 Uncamped Inductive Switching Test Circuit & Waveform

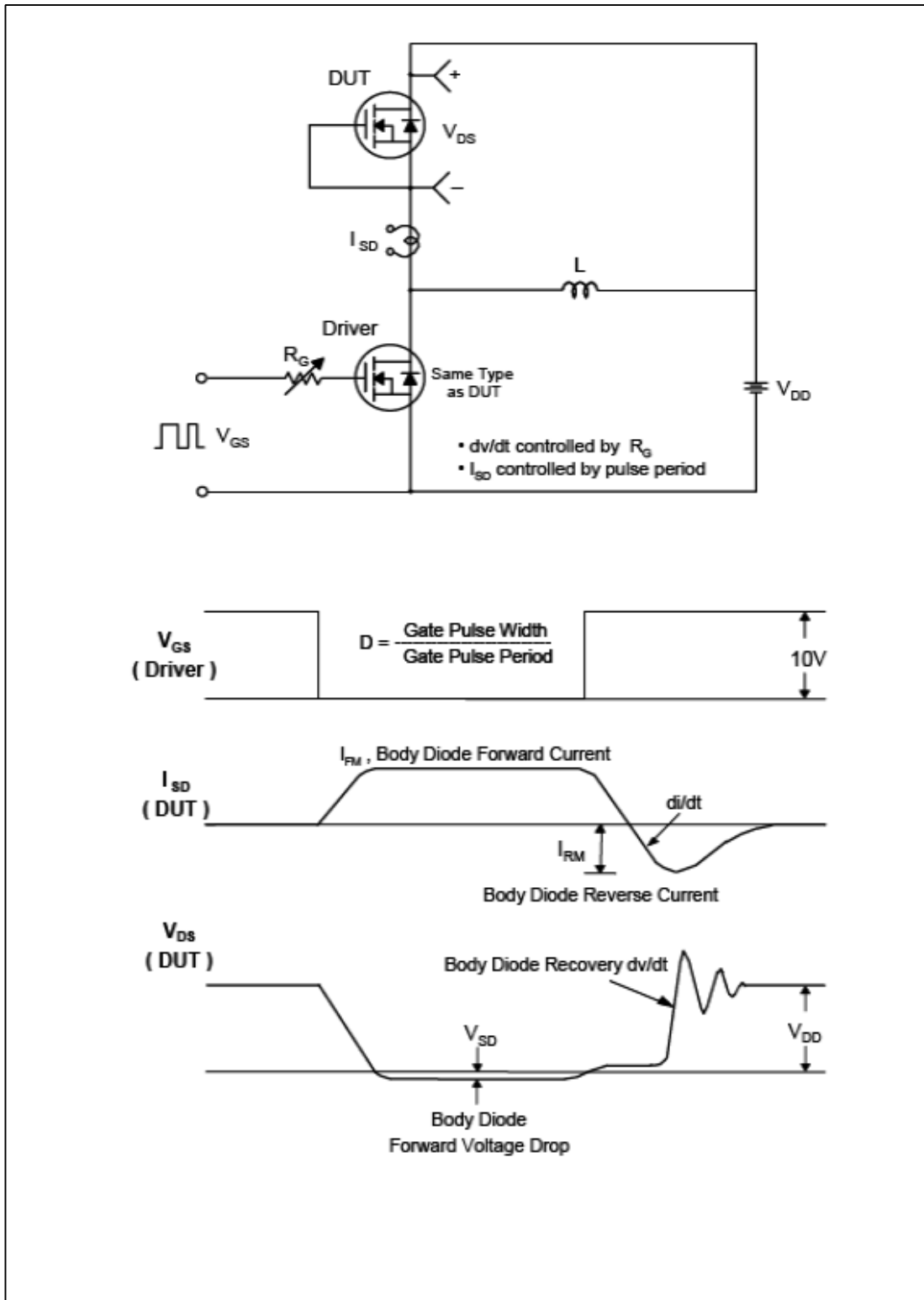

Fig.13 Peak Diode Recovery dv/dt Test Circuit & Waveform

TO-220 Package Dimension

