

Silicon N-Channel MOSFET

Features

- 10A,400V, $R_{DS(on)}$ (Max 0.55 Ω)@ $V_{GS}=10V$
- Ultra-low Gate Charge(Typical 60nC)
- Fast Switching Capability
- 100%Avalanche Tested
- Maximum Junction Temperature Range(150 °C)

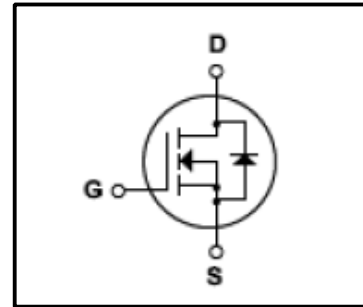

General Description

This Power MOSFET is produced using Winsemi's advanced planar stripe, VDMOS technology. This latest technology has been especially designed to minimize on-state resistance, have a high rugged avalanche characteristics. This device is specially well suited for high efficiency switch mode power supplies, power factor correction and half bridge and full bridge resonant topology line a electronic lamp ballast.

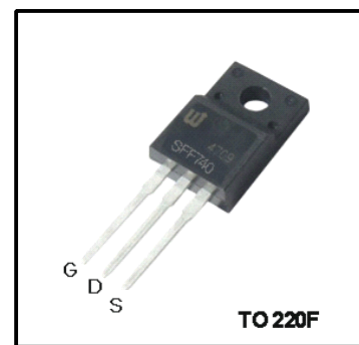

Absolute Maximum Ratings

| Symbol | Parameter | Value | Units |
|----------------|---|----------|-------|
| V_{DSS} | Drain Source Voltage | 400 | V |
| I_D | Continuous Drain Current(@ $T_c=25^\circ C$) | 10* | A |
| | Continuous Drain Current(@ $T_c=100^\circ C$) | 6.3* | A |
| I_{DM} | Drain Current Pulsed (Note1) | 40* | A |
| V_{GS} | Gate to Source Voltage | ± 30 | V |
| E_{AS} | Single Pulsed Avalanche Energy (Note2) | 450 | mJ |
| E_{AR} | Repetitive Avalanche Energy (Note1) | 13 | mJ |
| dv/dt | Peak Diode Recovery dv /dt (Note3) | 4 | V/ ns |
| P_D | Total Power Dissipation(@ $T_c=25^\circ C$) | 44 | W |
| | Derating Factor above 25°C | 0.35 | W/°C |
| T_J, T_{stg} | Junction and Storage Temperature | -55~150 | °C |
| T_L | Maximum lead Temperature for soldering purposes | 300 | °C |

*Drain current limited by maximum junction temperature

Thermal Characteristics

| Symbol | Parameter | Value | | | Units |
|-----------|---|-------|-----|------|-------|
| | | Min | Typ | Max | |
| R_{QJC} | Thermal Resistance , Junction -to -Case | - | - | 2.86 | °C/W |
| R_{QJA} | Thermal Resistance , Junction-to -Ambient | - | - | 62.5 | °C/W |

Electrical Characteristics(Tc=25°C)

| Characteristics | Symbol | Test Condition | Min | Type | Max | Unit | |
|--|---|---|---|------|------|------|----|
| Gate leakage current | I _{GSS} | V _{GS} =±30V,V _{DS} =0V | - | - | ±100 | nA | |
| Gate-source breakdown voltage | V _{(BR)GSS} | I _G =±10 μA,V _{DS} =0V | ±30 | - | - | V | |
| Drain cut -off current | I _{DSS} | V _{DS} =400V,V _{GS} =0V | - | - | 25 | μA | |
| Drain -source breakdown voltage | V _{(BR)DSS} | I _D =250 μA,V _{GS} =0V | 400 | - | - | V | |
| Break voltage Temperature Coefficient | ΔBV _{DSS} / ΔT _J | I _D =250μA, Referenced to 25°C | - | 0.4 | - | V/°C | |
| Gate threshold voltage | V _{GS(th)} | V _{DS} =10V,I _D =250 μA | 2 | - | 4 | V | |
| Drain -source ON resistance | R _{DS(ON)} | V _{GS} =10V,I _D =5A | - | 0.48 | 0.55 | Ω | |
| Forward Transconductance | g _{fs} | V _{DS} =40V,I _D =5A | - | 9.6 | - | S | |
| Input capacitance | C _{iss} | V _{DS} =25V, | - | 1400 | 1800 | pF | |
| Reverse transfer capacitance | C _{rss} | V _{GS} =0V, | - | 36 | 46 | | |
| Output capacitance | C _{oss} | f=1MHz | - | 150 | 195 | | |
| Switching time | Rise time | tr | V _{DD} =200V, I _D =10A, R _G =25Ω, (Note4,5) | - | 20 | 50 | ns |
| | Turn-on time | ton | | - | 80 | 170 | |
| | Fall time | tf | | - | 125 | 260 | |
| | Turn-off time | toff | | - | 85 | 180 | |
| Total gate charge(gate-source plus gate-drain) | Q _g | V _{DD} =320V, V _{GS} =10V, | - | 60 | 71 | nC | |
| Gate-source charge | Q _{gs} | I _D =10A | - | 7 | - | | |
| Gate-drain("miller") Charge | Q _{gd} | (Note4,5) | - | 27 | - | | |

Source-Drain Ratings and Characteristics(Ta=25°C)

| Characteristics | Symbol | Test Condition | Min | Type | Max | Unit |
|----------------------------------|------------------|---|-----|------|-----|------|
| Continuous drain reverse current | I _{DR} | - | - | - | 10 | A |
| Pulse drain reverse current | I _{DRP} | - | - | - | 40 | A |
| Forward voltage(diode) | V _{DSF} | I _{DR} =10A,V _{GS} =0V | - | 1.4 | 1.5 | V |
| Reverse recovery time | trr | I _{DR} =10A,V _{GS} =0V, | - | 330 | - | ns |
| Reverse recovery charge | Q _{rr} | dI _{DR} / dt =100 A / μs | - | 3.57 | - | μC |

Note 1.Repeativity rating :pulse width limited by junction temperature

2.L=7.9mH I_{AS}=10A,V_{DD}=50V,R_G=0Ω ,Starting T_J=25°C

3.I_{SD}≤10A,di/dt≤300A/us,V_{DD}<BV_{DSS},STARTING T_J=25°C

4.Pulse Test:Pulse Width≤300us,Duty Cycles≤2%

5. Essentially independent of operating temperature.

This transistor is an electrostatic sensitive device

Please handle with caution

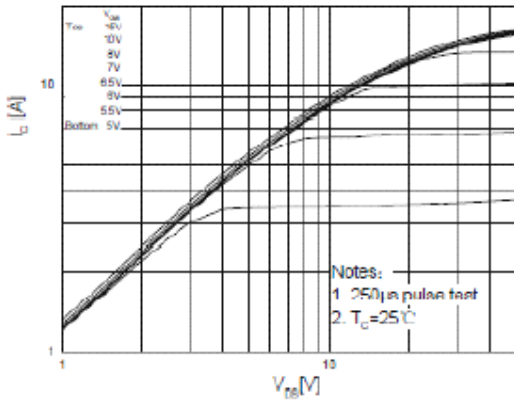

Fig.1 On-State Characteristics

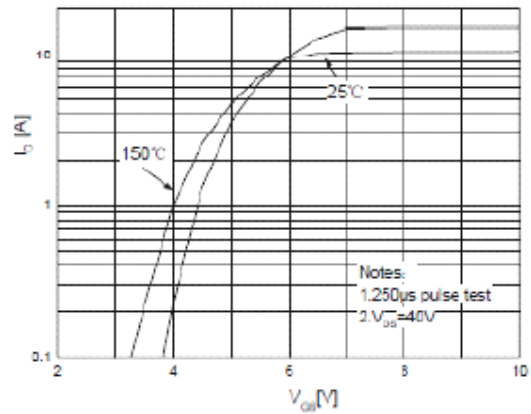

Fig.2 Transfer characteristics

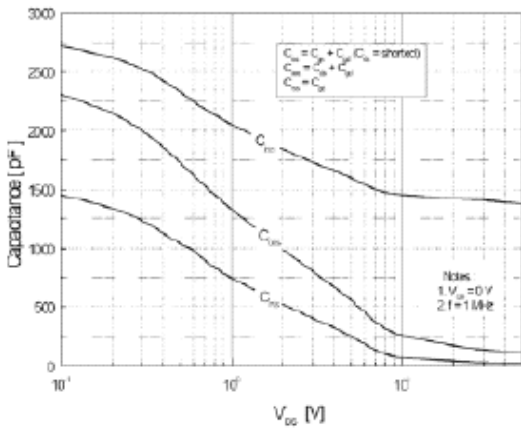

Fig.3 Capacitance Variation vs Drain Voltage

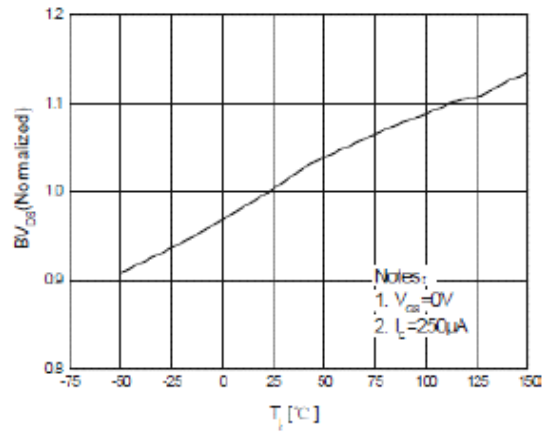

Fig.4 Breakdown voltage Variation vs Temperature

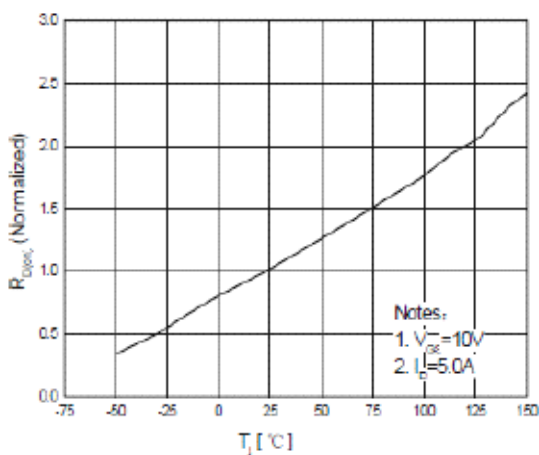

Fig.5 On-Resistance Variation vs Junction Temperature

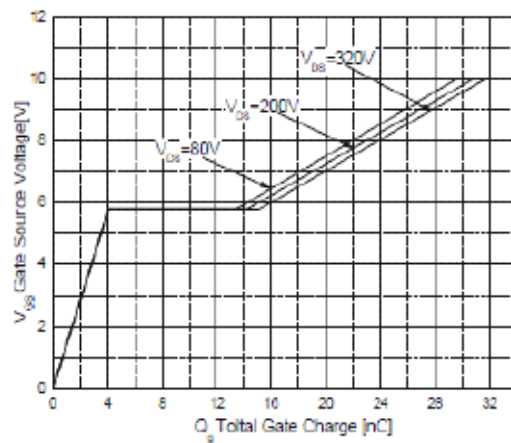

Fig.6 Gate Charge Characteristics

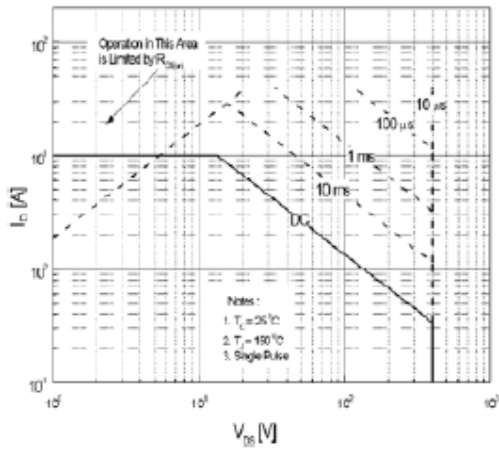

Fig.7 Maximum Safe Operation Area

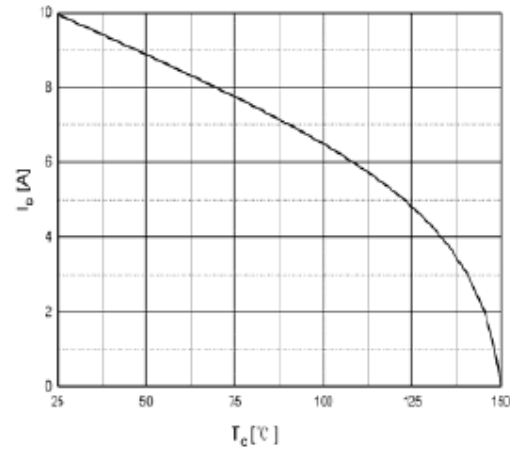

Fig.8 Maximum Drain Current vs Case Temperature

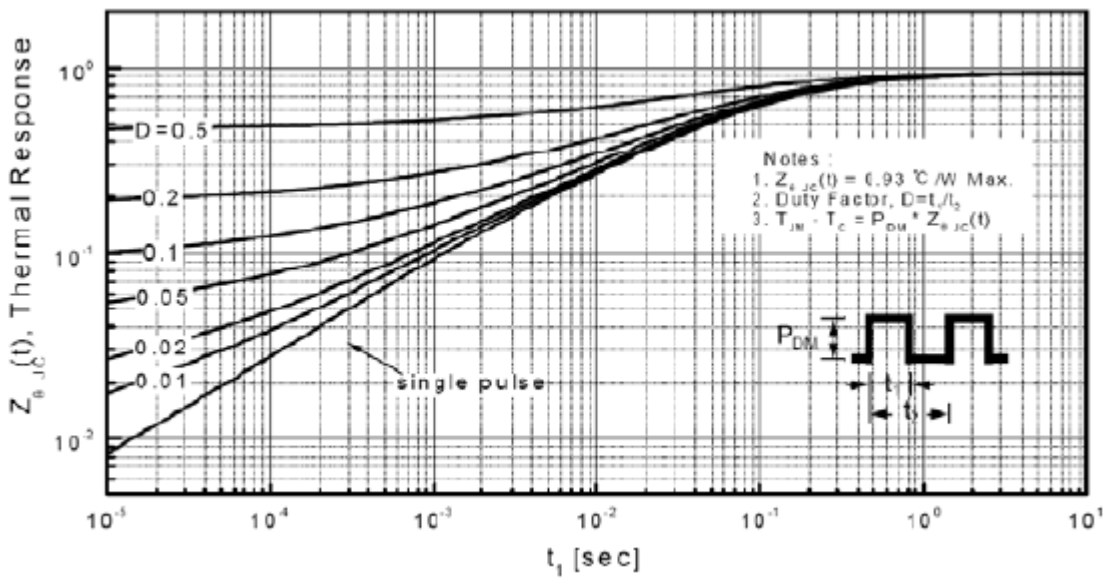

Fig.9 Transient Thermal Response curve

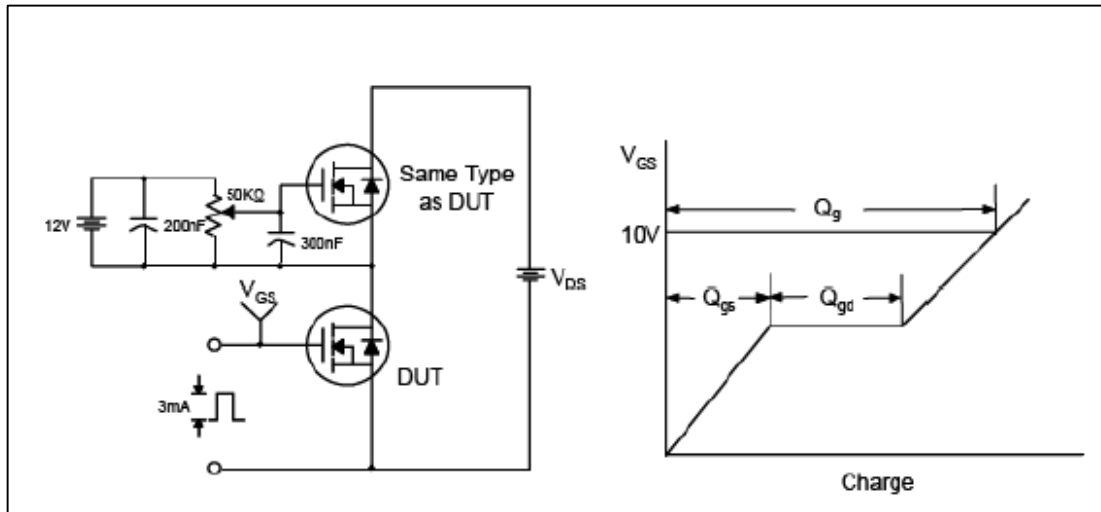

Fig.10 Gate Test circuit & Waveform

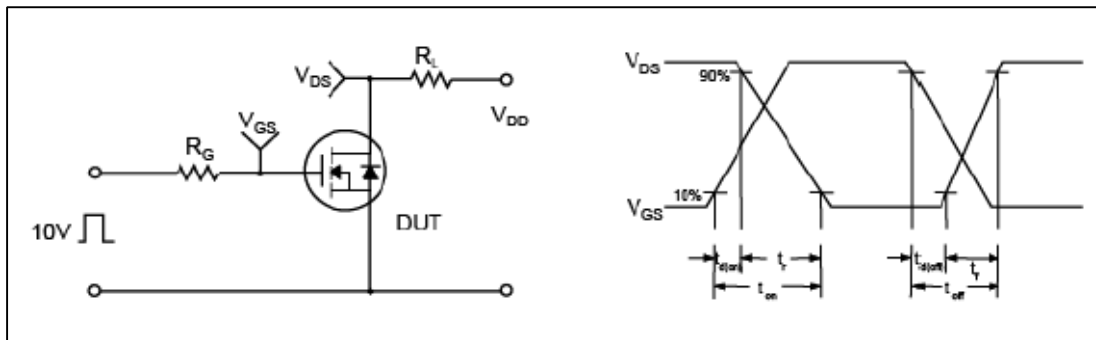

Fig.11 Resistive Switching Test Circuit & Waveform

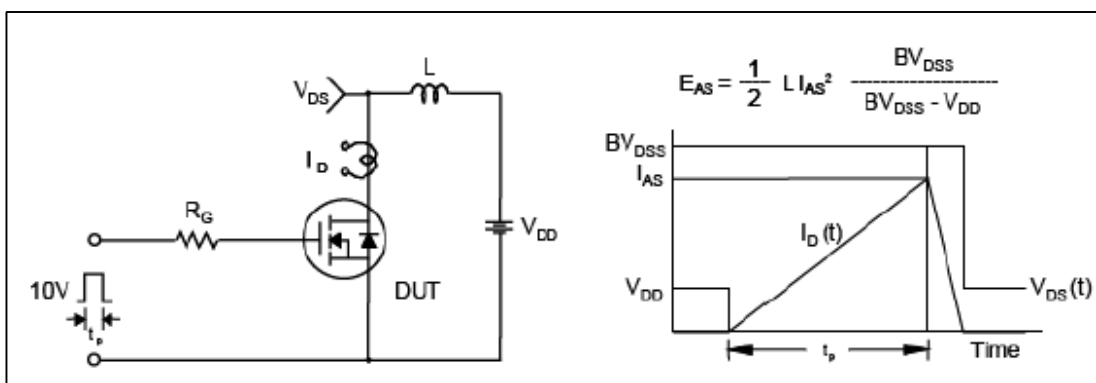

Fig.12 Uncamped Inductive Switching Test Circuit & Waveform

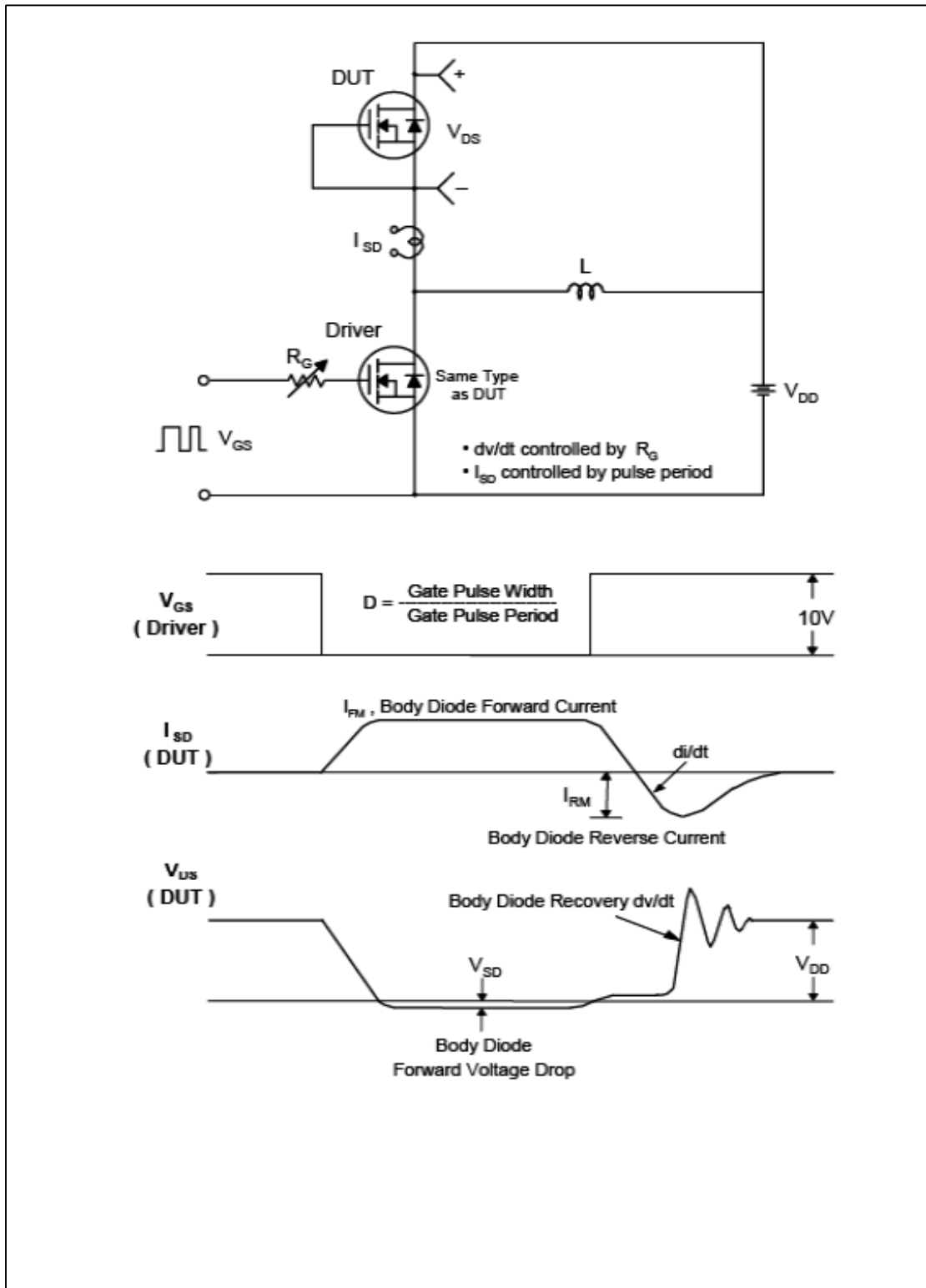

Fig.13 Peak Diode Recovery dv/dt Test Circuit & Waveform

TO-220F Package Dimension

