

Description

The MOSFET provide the best combination of fast switching, low on-resistance and cost-effectiveness.

MOSFET Product Summary		
V _{DS} (V)	R _{DS(on)} (Ω)	I _D (A)
20	0.29@ V _{GS} =4.5V	0.5

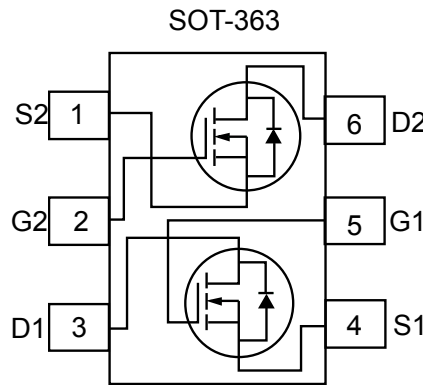

Absolute maximum rating@25°C

Parameter	Symbol	Maximum	Units
Drain-Source Voltage	V _{DS}	20	V
Gate-Source Voltage	V _{GS}	8	V
Continuous Drain Current(T _J =150°C)	I _D	Continuous	0.5
		Pulsed	1.5
Maximum Power Dissipation	P _D	0.3	W
Operating Junction and Storage Temperature Range	T _J , T _{STG}	-55 to 150	°C
Electrostatic Discharge Rating MIL-STD-883D Human Body Model (100pF/1500Ω)	ESD	6.0	kV
Thermal Characteristics			
Parameter	Symbol	Maximum	Units
Thermal Resistance, Junction-to-Ambient	R _{θJA}	415	°C/W

Electrical characteristics per line@25 °C (unless otherwise specified)

Parameter	Symbol	Conditions	Min.	Typ.	Max.	Units
Drain-Source Breakdown Voltage	BV_{DSS}	$I_D = 250\mu A, V_{GS} = 0V$	20		-	V
Zero Gate Voltage Drain Current	I_{DSS}	$V_{DS} = 20V, V_{GS} = 0V$	-	-	1	μA
Gate-Body Leakage Current	I_{GSS}	$V_{DS} = 0V, V_{GS} = 8V$	-	-	100	nA
Gate Threshold Voltage	$V_{GS(th)}$	$V_{DS} = V_{GS}, I_D = 250\mu A$	0.65	0.8	1.5	V
Static Drain-Source On-Resistance	$R_{DS(ON)}$	$V_{GS} = 4.5V, I_D = 0.5A$		0.29	0.34	Ω
		$V_{GS} = 2.7V, I_D = 0.2A$		0.35	0.42	
On-State Drain Current	$I_{D(ON)}$	$V_{GS} = 2.7V, V_{DS} = 5V$	0.5			A
Forward Trans conductance	g_{FS}	$V_{DS} = 5V, I_D = 0.5A$		1.45		S
Total Gate Charge	Q_g	$V_{GS} = 4.5V, V_{DS} = 5V,$ $I_D = 0.5A$		1.64	2.3	nC
Gate-Source Charge	Q_{gs}			0.38		
Gate-Drain Charge	Q_{gd}			0.45		
Input Capacitance	C_{ISS}	$V_{GS} = 0V, V_{DS} = 10V,$ $f = 1MHz$	-	50		pF
Output Capacitance	C_{OSS}		-	28		pF
Reverse Transfer Capacitance	C_{RSS}		-	9		pF
Turn-On Delay Time	$t_{d(on)}$	$V_{DD} = 5V, R_{GEN} = 50\Omega,$ $V_{GS} = 4.5V, I_D = 0.5A$	-	3	6	ns
Turn-Off Delay Time	$t_{d(off)}$		-	17	30	ns
Turn-On Rise Time	t_r		-	8.5	18	ns
Turn-On Fall Time	t_f		-	13	25	ns
Drain-Source Diode Forward Voltage	V_{SD}	$V_{GS} = 0V, I_S = 0.25A$		0.8	1.2	V
Maximum Body-Diode Continuous Current	I_S				0.25	A

Typical Characteristics

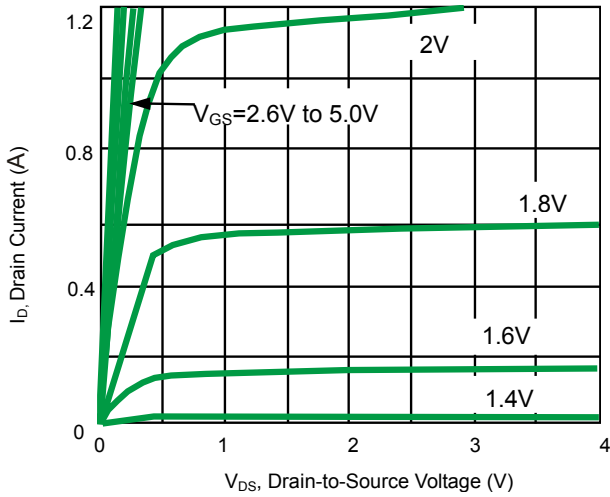

Fig 1. On-Region Characteristics

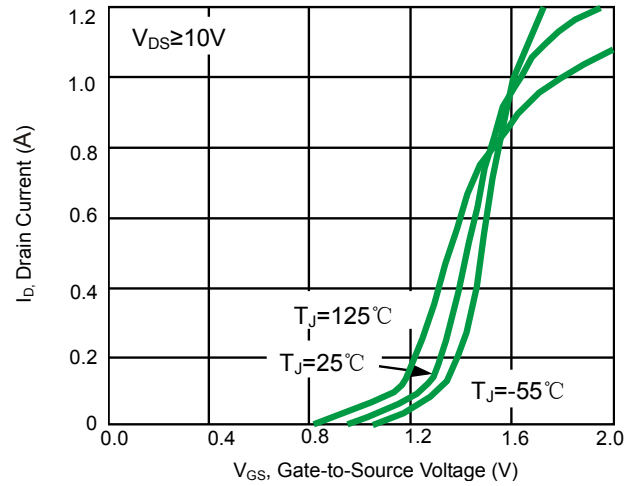

Fig 2. Transfer Characteristics

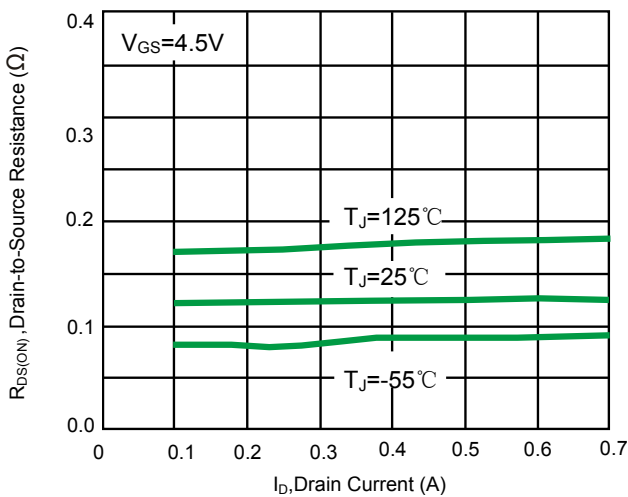

Fig 3. On-Resistance vs. Drain Current and Temperature

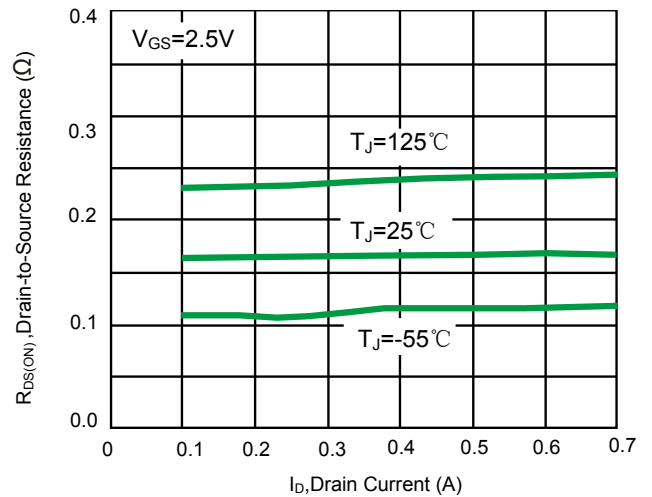

Fig 4. On-Resistance vs. Drain Current and Temperature

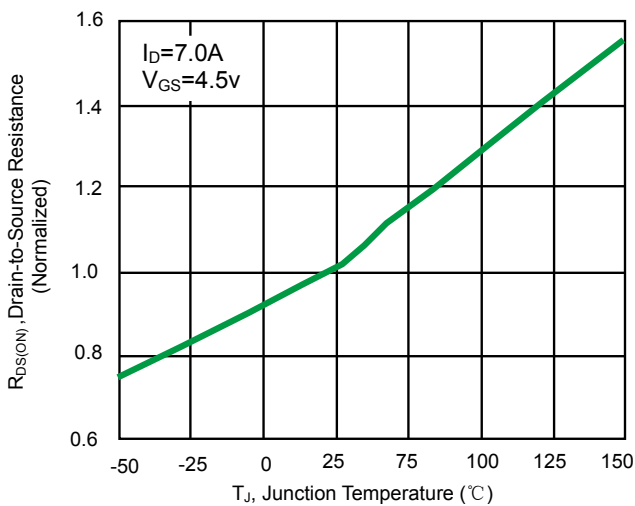

Fig 5. On-Resistance Variation with Temperature

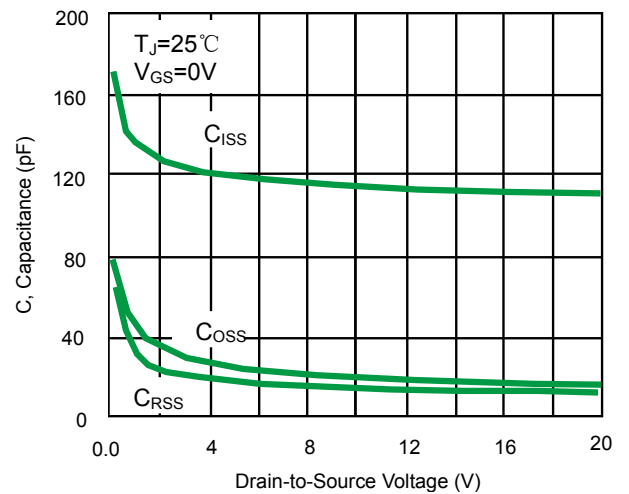

Fig 6. Characteristics Variation

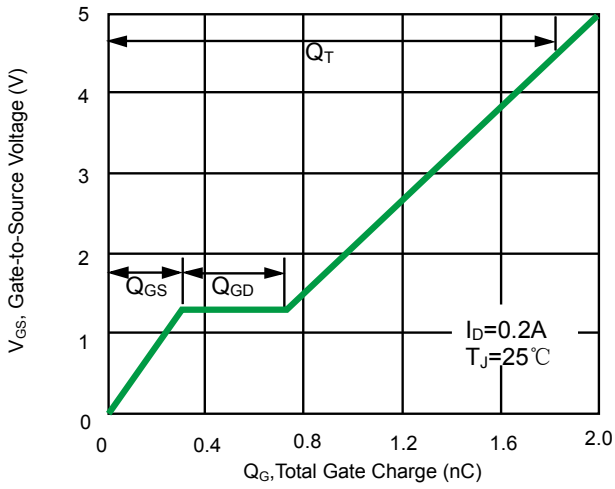

Fig 7. Gate-to-Source Voltage vs. Total Gate Charge

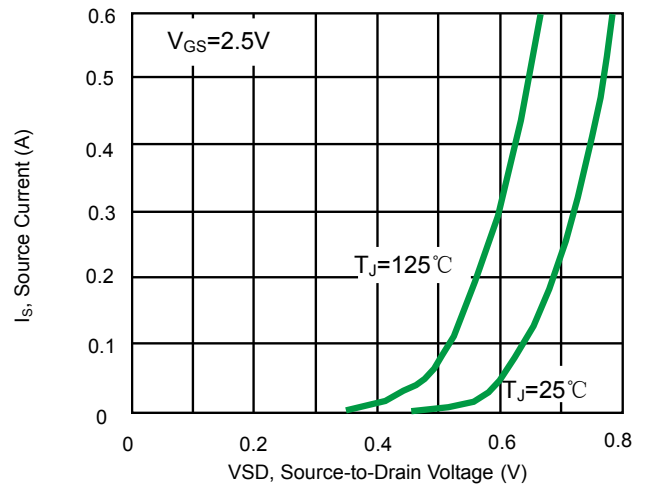

Fig 8. Diode Forward Voltage vs. Current

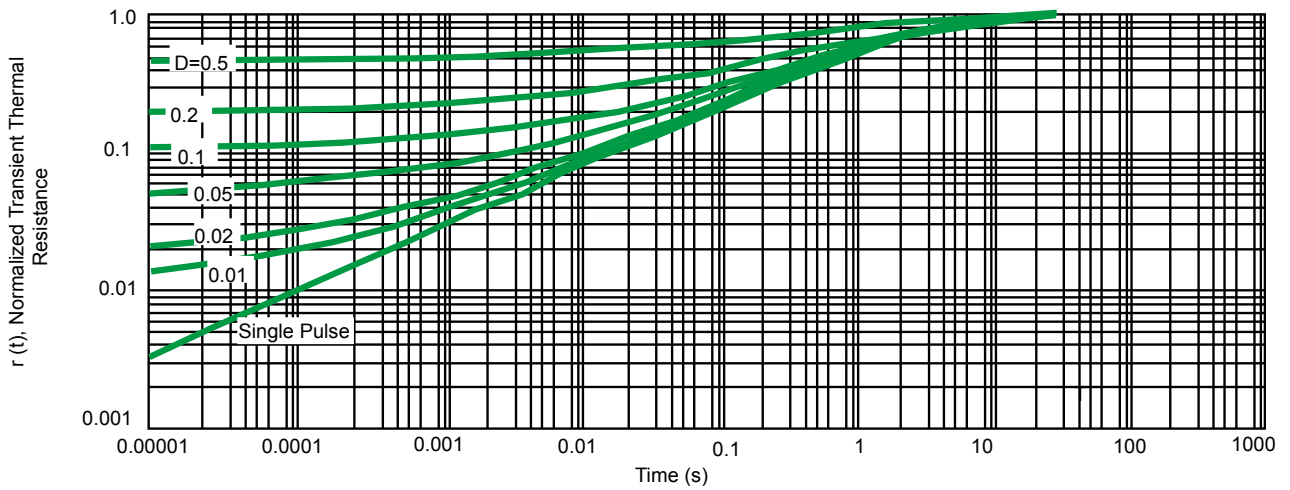
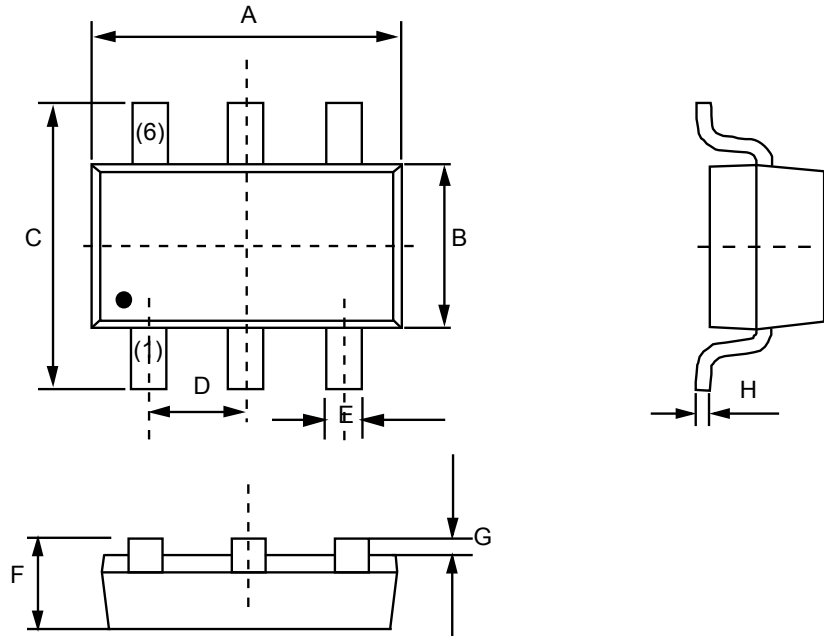



Fig 9. Normalized Thermal Response

Product dimension (SOT-363)



Dim	Millimeters		Inches	
	MIN	MAX	MIN	MAX
A	2.0	2.2	0.079	0.087
B	1.15	1.35	0.045	0.053
C	2.15	2.45	0.085	0.096
D	0.65BSC		0.026BSC	
E	0.15	0.35	0.006	0.014
F	0.90	1.10	0.035	0.043
G	0.00	0.10	0.000	0.004
H	0.08	0.15	0.003	0.006

IMPORTANT NOTICE

 and **Prisemi**[®] are registered trademarks of **Prisemi Electronics Co., Ltd (Prisemi)** ,Prisemi reserves the right to make changes without further notice to any products herein. Prisemi makes no warranty, representation or guarantee regarding the suitability of its products for any particular purpose, nor does Prisemi assume any liability arising out of the application or use of any product or circuit, and specifically disclaims any and all liability, including without limitation special, consequential or incidental damages. “Typical” parameters which may be provided in Prisemi data sheets and/or specifications can and do vary in different applications and actual performance may vary over time. All operating parameters, including “Typicals” must be validated for each customer application by customer’s technical experts. Prisemi does not convey any license under its patent rights nor the rights of others. The products listed in this document are designed to be used with ordinary electronic equipment or devices, Should you intend to use these products with equipment or devices which require an extremely high level of reliability and the malfunction of with would directly endanger human life (such as medical instruments, aerospace machinery, nuclear-reactor controllers, fuel controllers and other safety devices), please be sure to consult with our sales representative in advance.

Website: <http://www.prisemi.com>

For additional information, please contact your local Sales Representative.

©Copyright 2009, Prisemi Electronics

 **Prisemi**[®] is a registered trademark of Prisemi Electronics.

All rights are reserved.