

Power MOSFET Stage for Boost Converters

PSBM 24/05

$$I_{D25} = 35 \text{ A}$$

$$V_{DSS} = 500 \text{ V}$$

$$R_{DS(on)} = 0.12 \Omega$$

Module for Power Factor Correction

Preliminary Data Sheet

V_{RSM} (V)	V_{RRM} (V)	Type
600	500	PSBM 24/05

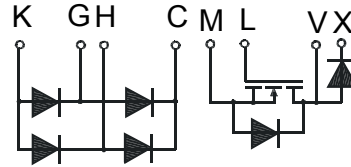

1 2
NTC optional



MOSFET

Symbol	Test Conditions	Maximum Ratings	
V_{DSS}	$T_{VJ} = 25 \text{ °C to } 150 \text{ °C}$	500	V
V_{DGR}	$T_{VJ} = 25 \text{ °C to } 150 \text{ °C}, R_{GS} = 10 \Omega$	500	V
V_{GS}	continuous	± 20	V
I_D	$T_s = 85 \text{ °C}$	24	A
I_D	$T_s = 25 \text{ °C}$	35	A
I_{DM}	$T_s = 25 \text{ °C}$, pulse width limited by T_{VJ}	95	A
P_D	$T_s = 85 \text{ °C}$	170	W
I_S	$V_{GS} = 0 \text{ V}, T_s = 25 \text{ °C}$	24	A
I_{SM}	$V_{GS} = 0 \text{ V}, T_s = 25 \text{ °C}$, pulse width limited by T_{VJ}	95	A

Symbol	Test Conditions	Characteristic Values	
$T_{VJ} = 25 \text{ °C}$, unless otherwise specified			
V_{DSS}	$V_{GS} = 0 \text{ V}, I_D = 2 \text{ mA}$	min. 500	V
$V_{GS(th)}$	$V_{DS} = 20 \text{ V}, I_D = 20 \text{ mA}$	min. 2	V
$V_{GS(th)}$	$V_{DS} = 20 \text{ V}, I_D = 20 \text{ mA}$	max. 5	V
I_{GSS}	$V_{GS} = \pm 20 \text{ V}, V_{DS} = 0 \text{ V}$	max. ± 500	nA
I_{DSS}	$V_{DS} = 500 \text{ V}, V_{GS} = 0 \text{ V}$	max. 2	mA
$R_{DS(on)}$	$T_{VJ} = 25 \text{ °C}$	max. 0.12	Ω
R_{Gint}	$T_{VJ} = 25 \text{ °C}$	max. 1.5	Ω
g_{fs}	$V_{DS} = 15 \text{ V}, I_{DS} = 12 \text{ A}$	typ. 30	S
V_{DS}	$I_{DS} = 24 \text{ A}, V_{GS} = 0 \text{ V}$	max. 1.5	V
$t_{d(on)}$	$V_{DS} = 250 \text{ V}, I_{DS} = 12 \text{ A}, V_{GS} = 10 \text{ V}$ $Z_{gen} = 1 \Omega, L\text{-load}$	max. 100	ns
$t_{d(off)}$		max. 220	ns
C_{iss}	$V_{DS} = 25 \text{ V}, f = 1 \text{ MHz}, V_{GS} = 0 \text{ V}$	typ. 8.5	nF
C_{oss}		typ. 0.9	nF
C_{rss}		typ. 0.3	nF
Q_g	$V_{DS} = 250 \text{ V}, I_D = 12 \text{ A}, V_{GS} = 10 \text{ V}$	typ. 350	nC
R_{thJH}		max. 0.38	K/W

Module

Symbol	Test Conditions	Maximum Ratings	
T_{VJ}		-40...+150	$^{\circ}\text{C}$
T_{JM}		150	$^{\circ}\text{C}$
T_{stg}		-40...+150	$^{\circ}\text{C}$
V_{isol}	50/60 Hz $t = 1 \text{ min}$	3000	V~
	$I_{isol} \leq 1 \text{ mA}$ $t = 1 \text{ s}$	3600	V~
M_d	Mounting torque (M 4)	1.5-2.0	Nm
Weight	typ.	24	g

Features

- High level of integration - only one power semiconductor module required for the whole PFC rectifier
- Isolation voltage 3600 V~
- Planar glass passivated chips
- Ultrafast boost diode
- Leads suitable for PC board soldering
- Thermistor (optional)
- UL registered, E 148688

Applications

- Power factor pre-conditioner for SMPS, UPS, battery chargers and inverters
- Boost topology for SMPS including 1~ rectifier bridge
- Power supply for welding equipment

Advantages

- Easy to mount with two screws
- Space and weight savings
- high temperature and power cycling capability
- Small and light weight
- 3 functions in one package

Caution: These Devices are sensitive to electrostatic discharge. Users should observe proper ESD handling precautions.

Data according to IEC 60747 refer to a single diode unless otherwise stated

Boost Diode

Symbol	Test Conditions	Maximum Ratings	
V_{RRM}		600	V
I_{FAV}	$T_S = 85\text{ °C}$, rectangular $\delta = 0.5$	40	A
I_{FSM}	$T_{VJ} = 45\text{ °C}$, $T = 10\text{ ms}$ (50Hz)	300	A
		$T = 8.3\text{ ms}$ (60Hz)	320
	$T_{VJ} = 150\text{ °C}$, $T = 10\text{ ms}$ (50Hz)	260	A
		$T = 8.3\text{ ms}$ (60Hz)	280
P	$T_S = 85\text{ °C}$	36	W

Symbol Test Conditions Characteristic Values

$T_{VJ} = 25\text{ °C}$, unless otherwise specified

V_F	$I_F = 22\text{ A}$, $T_{VJ} = 25\text{ °C}$	max.	1.65	V	
		$T_{VJ} = 150\text{ °C}$	max.	1.4	V
I_R	$V_R = 600\text{ V}$, $T_{VJ} = 25\text{ °C}$	max.	1.5	mA	
		$V_R = 480\text{ V}$, $T_{VJ} = 25\text{ °C}$	max.	0.25	mA
		$T_{VJ} = 125\text{ °C}$	max.	7	mA
V_{T0}	for power-loss calculations only	max.	1.14	V	
r_T	$T_{VJ} = 125\text{ °C}$	max.	10	mΩ	
I_{RM}	$I_F = 30\text{ A}$, $-di_F/dt = 240\text{ A}/\mu\text{s}$	max.	11	A	
	$V_R = 350\text{ V}$, $T_{VJ} = 100\text{ °C}$	typ.	10	A	
R_{thJH}		max.	1.8	K/W	

Rectifier Diodes

Symbol	Test Conditions	Maximum Ratings	
V_{RRM}		800	V
I_{dAV}	$T_S = 85\text{ °C}$, sinus 180 °	40	A
I_{FSM}	$T_{VJ} = 45\text{ °C}$, $T = 10\text{ ms}$ (50Hz)	300	A
		$T = 8.3\text{ ms}$ (60Hz)	320
	$T_{VJ} = 150\text{ °C}$, $T = 10\text{ ms}$ (50Hz)	260	A
		$T = 8.3\text{ ms}$ (60Hz)	280
P	$T_S = 85\text{ °C}$	33	W

Symbol Test Conditions Characteristic Values

$T_{VJ} = 25\text{ °C}$, unless otherwise specified

V_F	$I_F = 20\text{ A}$, $T_{VJ} = 25\text{ °C}$	max.	1.4	V
		$T_{VJ} = 125\text{ °C}$	max.	1.4
I_R	$V_R = 800\text{ V}$, $T_{VJ} = 25\text{ °C}$	max.	0.25	mA
		$V_R = 640\text{ V}$, $T_{VJ} = 125\text{ °C}$	max.	2
V_{T0}	for power-loss calculations only	max.	1.05	V
r_T	$T_{VJ} = 125\text{ °C}$	max.	16	mΩ
R_{thJH}		max.	2.0	K/W

Module

Symbol	Test Conditions	Characteristic Values	
d_s	Creeping distance on surface	11.2	mm
d_A	Creeping distance in air	5.6	mm
a	Max. allowable acceleration	50	m/s ²
R_{25}^*	NTC @ 25 °C	470.000	Ω

Package style and outline

Dimensions in mm (1mm = 0.0394")

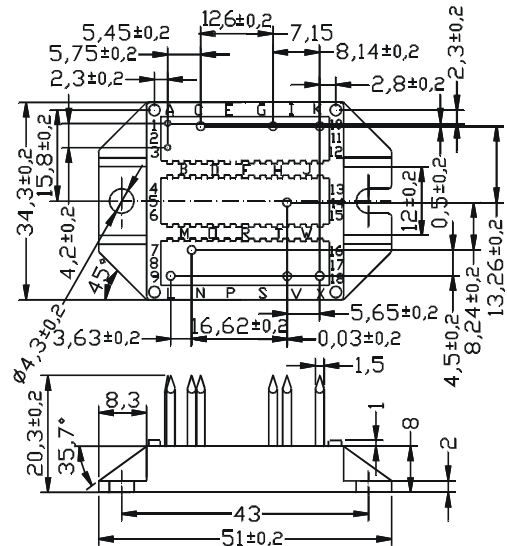

*NTC will be changed in future to 5.000 Ω.