

N-Channel Power MOSFET (50A, 60Volts)

DESCRIPTION

The Nell **50N06** is a three-terminal silicon device with current conduction capability of 50A, fast switching speed, low on-state resistance, breakdown voltage rating of 60V, and max. threshold voltage of 4 volts.

They are designed for use in applications such as switching regulators, switching converters, motor drivers and relay drivers. These transistors can be operated directly from integrated circuits.

FEATURES

- $R_{DS(ON)} = 22m\Omega @ V_{GS} = 10V$
- Ultra low gate charge(40nC max.)
- Low reverse transfer capacitance ($C_{RSS} = 80pF$ typical)
- Fast switching capability
- 100% avalanche energy specified
- Improved dv/dt capability
- 175°C operation temperature

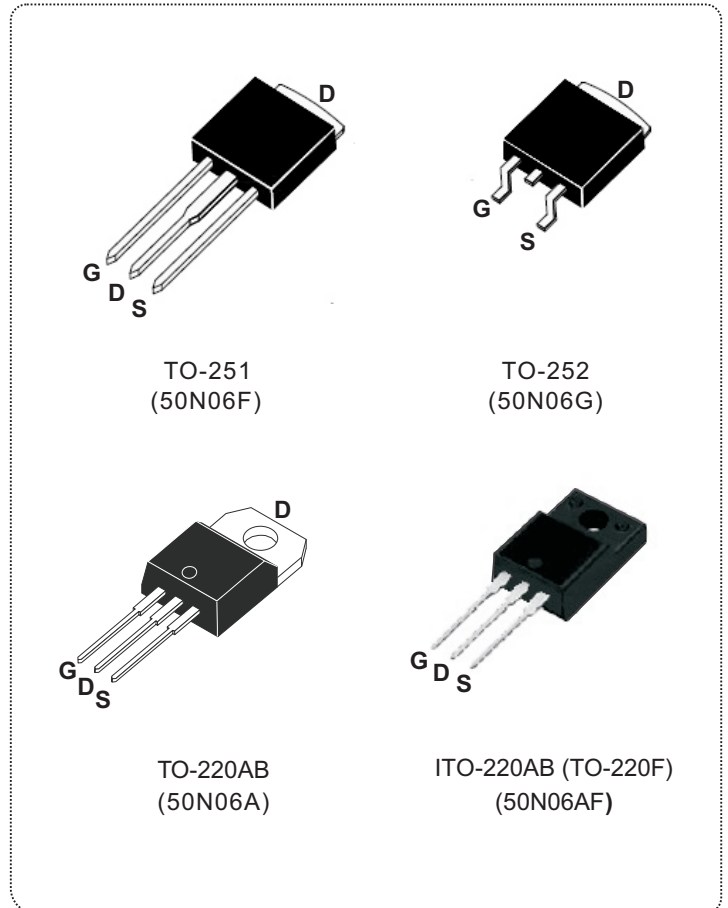

PRODUCT SUMMARY	
I_D (A)	50
V_{DSS} (V)	60
$R_{DS(ON)}$ (Ω)	0.022 @ $V_{GS} = 10V$
Q_G (nC) max.	40

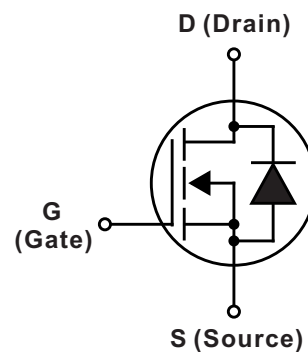

ABSOLUTE MAXIMUM RATINGS (T _C = 25°C unless otherwise specified)				
SYMBOL	PARAMETER	TEST CONDITIONS	VALUE	UNIT
V _{DSS}	Drain to Source voltag	T _J =25°C to 150°C	60	V
V _{DGR}	Drain to Gate voltage	R _{GS} =20KΩ	60	
V _{GS}	Gate to Source voltage		±20	
I _D	Continous Drain Current	T _C =25°C	50	A
		T _C =100°C	35	
I _{DM}	Pulsed Drain current(Note 1)		200	
E _{AS}	Single pulses avalanche energy(Note 2)		480	mJ
E _{AR}	Repetitive avalanche energy(Note 1)		13	
dv/dt	Peak diode recovery dv/dt(Note 3)		7	V/ns
P _D	Total power dissipation, T _C =25°C	TO-251	130	W
		TO-252	130	
		TO-220	120	
		TO-220F	70	
T _J	Operation junction temperature		-55 to 175	°C
T _{STG}	Storage temperature		-55 to 175	
T _L	Maximum soldering temperature, for 10 seconds	1.6mm from case	300	
	Mounting torque, #6-32 or M3 screw		10 (1.1)	lbf·in (N·m)

Note: 1.Repetitive rating: pulse width limited by junction temperature.
 2.L = 5.6mH, I_{AS} = 50A, V_{DD} = 25V, R_G = 0Ω, starting T_J=25°C.
 3.I_{SD} ≤ 50A, di/dt ≤ 300A/us, V_{DD} ≤ V_{(BR)DSS}, starting T_J=25°C.

THERMAL RESISTANCE					
SYMBOL	PARAMETER	Min.	Typ.	Max.	UNIT
R _{th(j-c)}	Thermal resistance, junction to case	TO-251/TO-252		1.15	°C/W
		TO-220		1.24	
		TO-220F		1.78	
R _{th(c-s)}	Thermal resistance, case to heatsink		0.5		
R _{th(j-a)}	Thermal resistance, junction to ambient	TO-251/TO-252		100	
		TO-220/TO-220F		62.5	

ELECTRICAL CHARACTERISTICS (T _C = 25°C unless otherwise specified)						
SYMBOL	PARAMETER	TEST CONDITIONS	Min.	Typ.	Max.	UNIT
V _{(BR)DSS}	Drain to source breakdown voltage	I _D = 250μA, V _{GS} = 0V	60			V
ΔV _{(BR)DSS} /ΔT _J	Breakdown voltage temperature coefficient	I _D = 250μA, referenced to 25°C		0.07		V/°C
I _{DSS}	Drain to source leakage current	V _{DS} = 60V, V _{GS} = 0V	T _C = 25°C		1.0	μA
			T _C = 150°C		50	
I _{GSS}	Gate to source forward leakage current	V _{GS} = 20V, V _{DS} = 0V			100	nA
	Gate to source reverse leakage current	V _{GS} = -20V, V _{DS} = 0V			-100	
R _{DS(ON)}	Static drain to source on-state resistance	I _D = 50A, V _{GS} = 10V		18	22	mΩ
V _{GS(TH)}	Gate threshold voltage	V _{GS} = V _{DS} , I _D = 250μA	2.0		4.0	V
C _{ISS}	Input capacitance	V _{DS} = 25V, V _{GS} = 0V, f = 1MHz		900	1220	pF
C _{OSS}	Output capacitance			430	550	
C _{RSS}	Reverse transfer capacitance			80	100	
t _{d(ON)}	Turn-on delay time	V _{DD} = 30V, I _D = 25A, R _G = 50Ω (Note 1, 2)		40	60	ns
t _r	Rise time			100	200	
t _{d(OFF)}	Turn-off delay time			90	180	
t _f	Fall time			80	160	
Q _G	Total gate charge	V _{DS} = 48V, V _{GS} = 10V, I _D = 50A (Note 1, 2)		30	40	nC
Q _{GS}	Gate to source charge			9.6		
Q _{GD}	Gate to drain charge (Miller charge)			10		

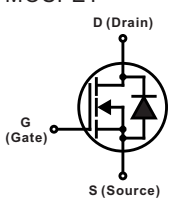
SOURCE TO DRAIN DIODE RATINGS AND CHARACTERISTICS (T _C = 25°C unless otherwise specified)						
SYMBOL	PARAMETER	TEST CONDITIONS	Min.	Typ.	Max.	UNIT
V _{SD}	Diode forward voltage	I _{SD} = 50A, V _{GS} = 0V			1.5	V
I _S	Continuous source current	Integral reverse P-N junction diode in the MOSFET 			50	A
I _{SM}	Pulsed source current				200	
t _{rr}	Reverse recovery time	I _S = 50A, V _{GS} = 0V, dI _F /dt = 100A/μs		55		ns
Q _{rr}	Reverse recovery charge				80	

Note: 1. Pulse test: Pulse width ≤ 300μs, duty cycle ≤ 2%.
2. Essentially independent of operating temperature.

ORDERING INFORMATION SCHEME

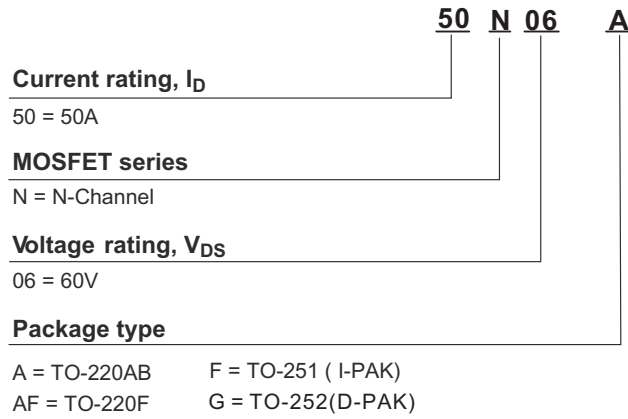

■ TEST CIRCUITS AND WAVEFORMS

Fig.1A Peak diode recovery dv/dt test circuit

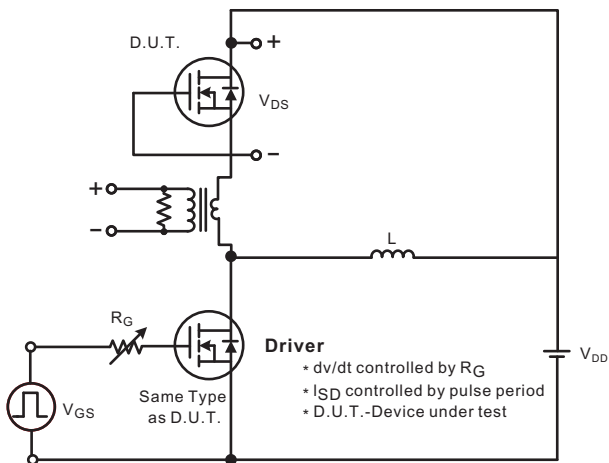
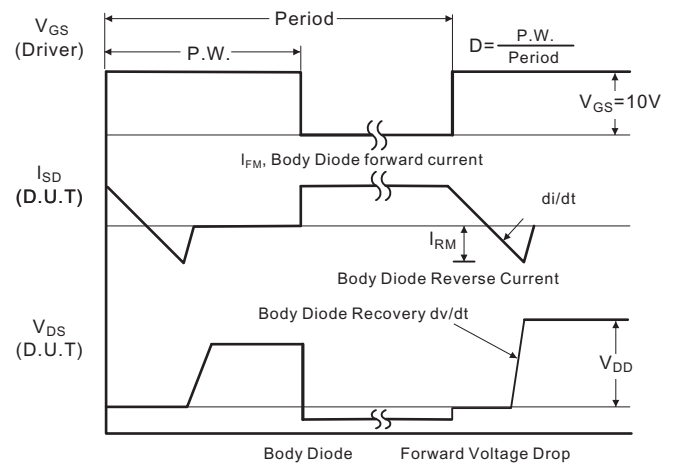

Fig.1B Peak diode recovery dv/dt waveforms



■ TEST CIRCUITS AND WAVEFORMS (Cont.)

Fig.2A Switching test circuit

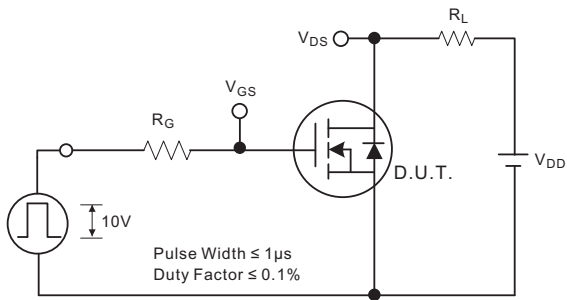

Fig.2B Switching Waveforms

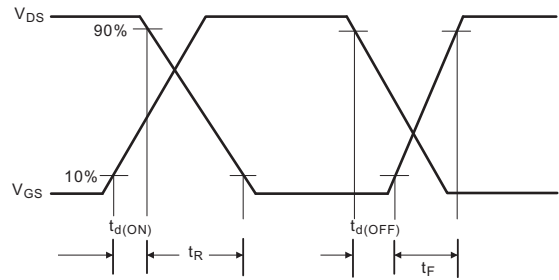

Fig.3A Gate charge test circuit

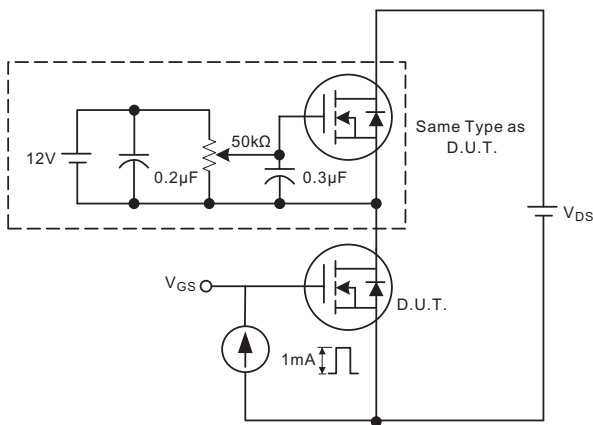

Fig.3B Gate charge waveform

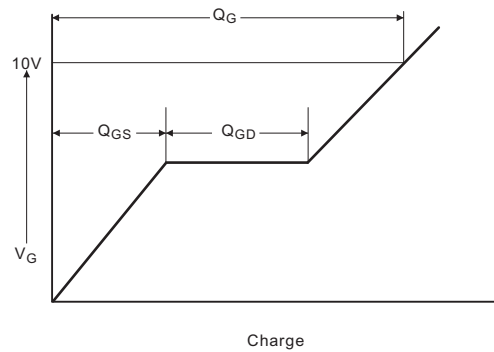

Fig.4A Unclamped Inductive switching test circuit

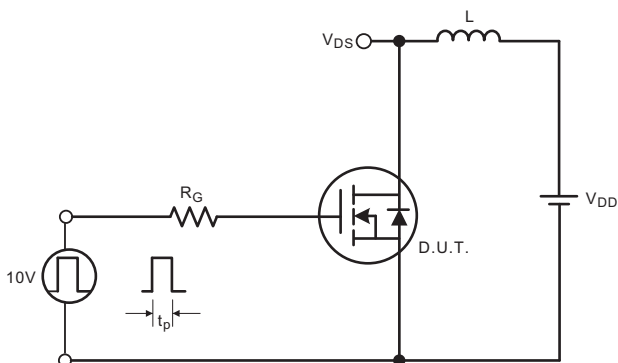
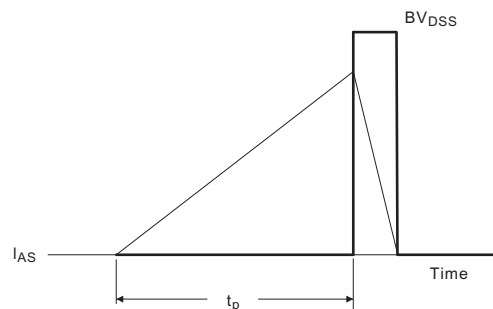

Fig.4B Unclamped Inductive switching waveforms



■ TYPICAL CHARACTERISTICS

Fig.1 On-State characteristics

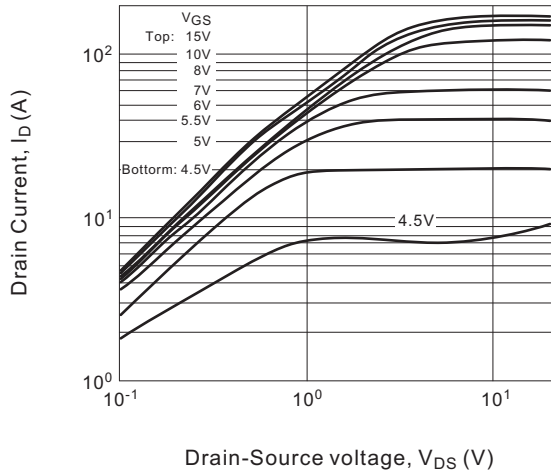

Fig.2 Transfer characteristics

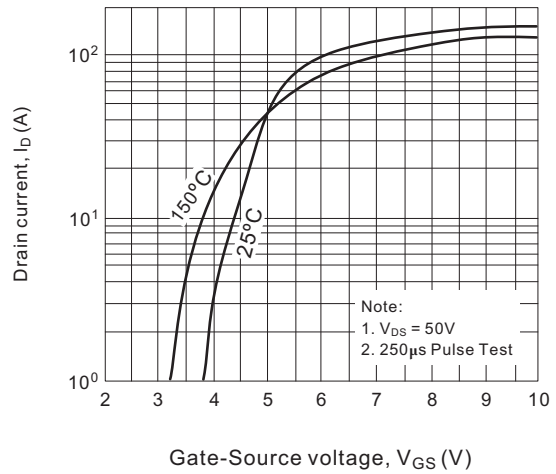

Fig.3 On-Resistance variation vs drain current and gate voltage

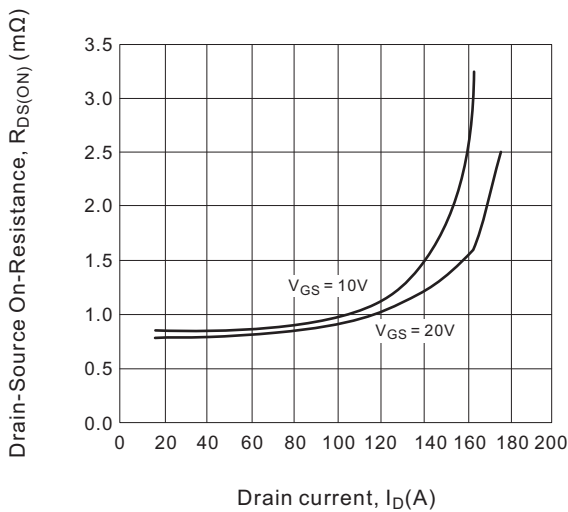

Fig.4 On state current vs. allowable case temperature

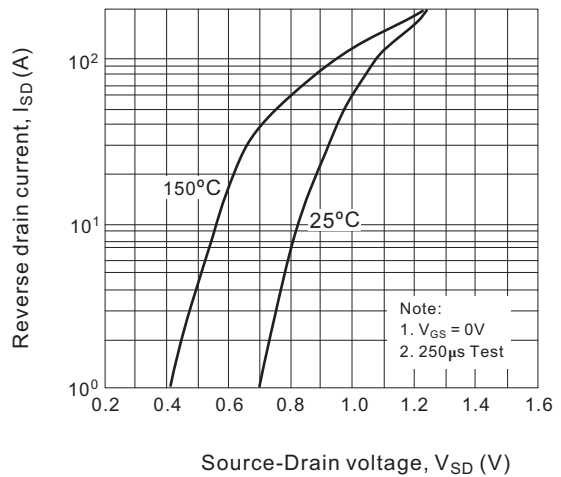

Fig.5 Capacitance characteristics (Non-Repetitive)

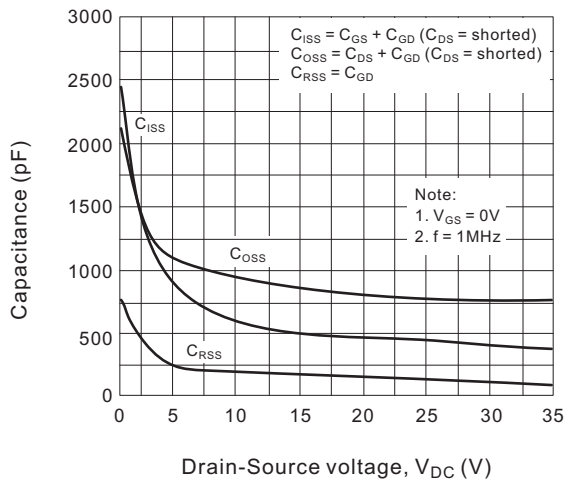

Fig.6 Gate charge characteristics

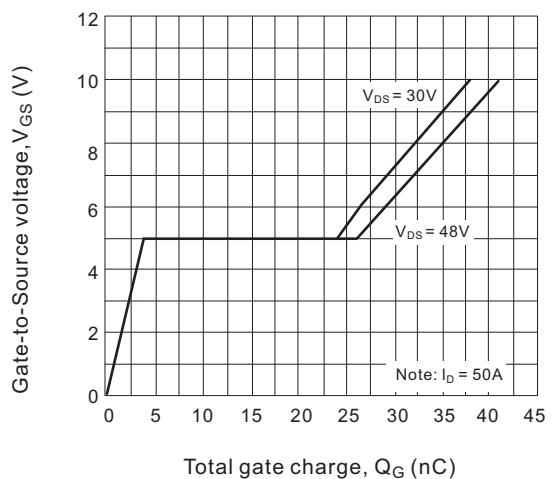

Fig.7 Breakdown voltage variation vs junction temperature

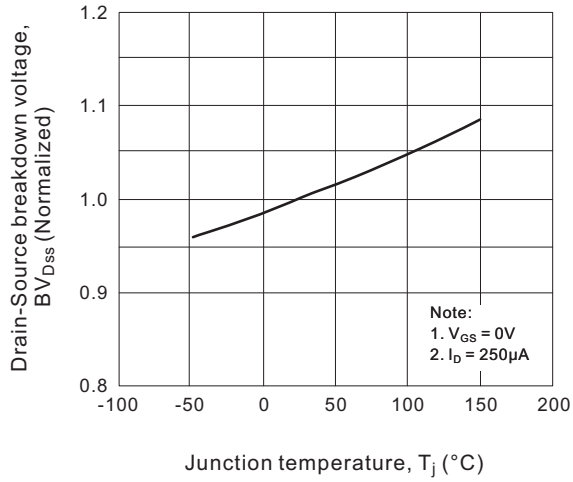

Fig.8 On-Resistance variation vs junction temperature

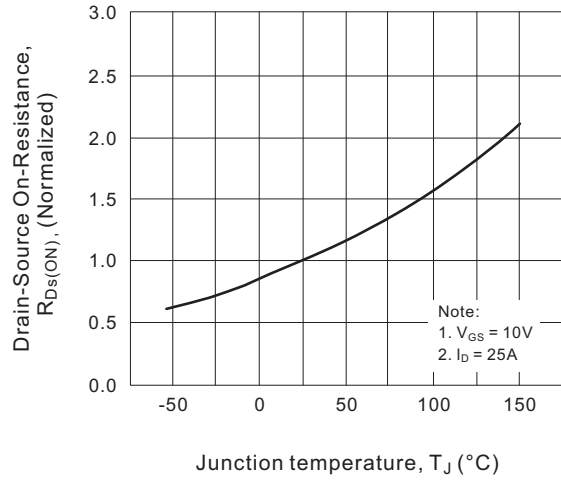

Fig.9 Maximum safe operating

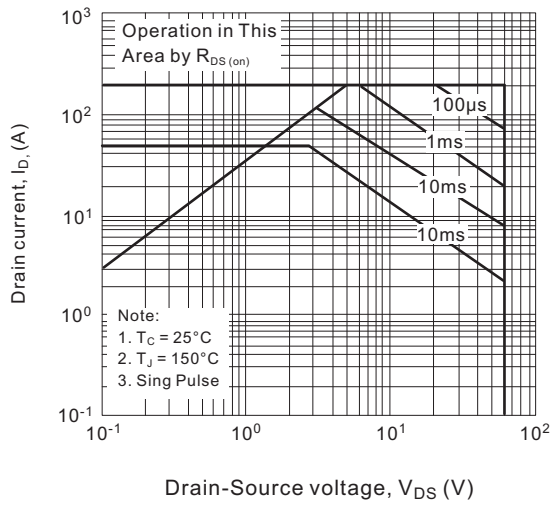

Fig.10 Maximum drain current vs. case temperature

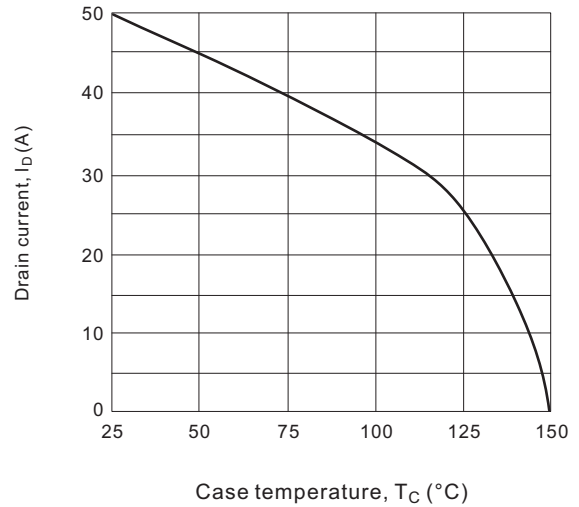
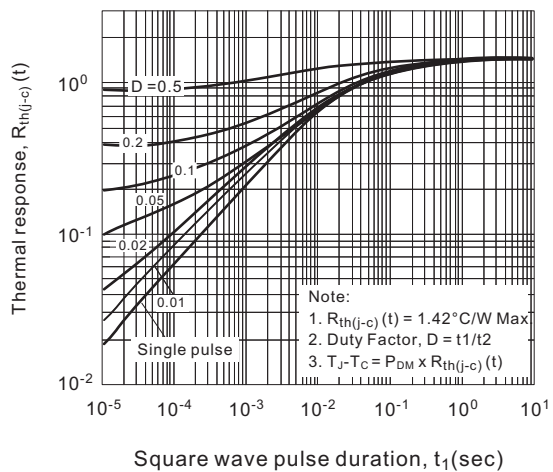

Fig.11 Transient thermal response curve



Case Style

Nell High Power Products

TO-220AB

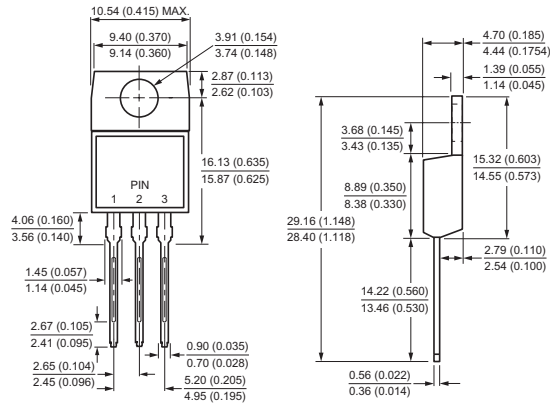

TO-251 (I-PAK)

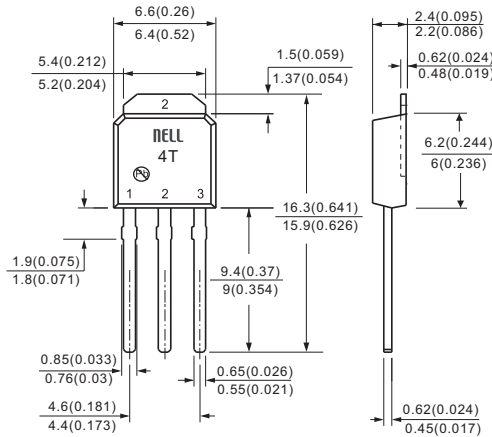

TO-252 (D-PAK)

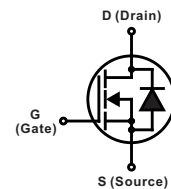
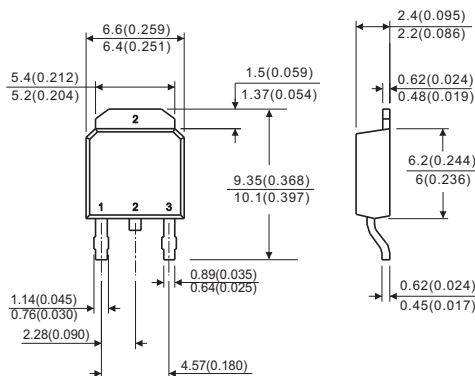

All dimensions in millimeters(inches)

Case Style

ITO-220AB

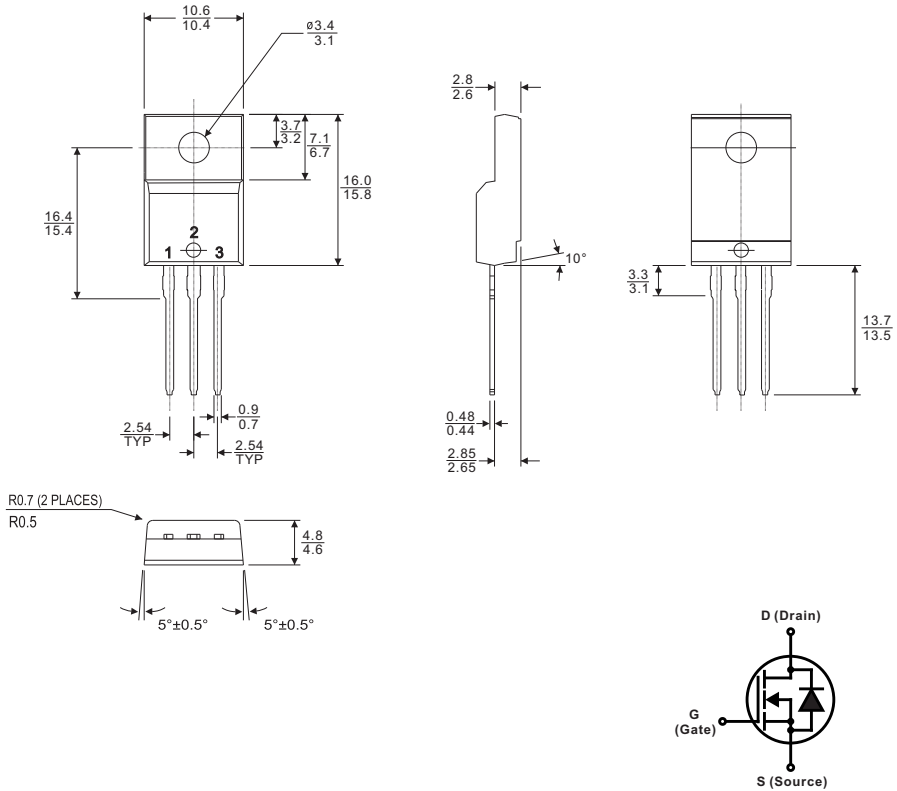

All dimensions in millimeters