



# C2M0160120D

## Silicon Carbide Power MOSFET Z-FET™ MOSFET

N-Channel Enhancement Mode

### Features

- High Speed Switching with Low Capacitances
- High Blocking Voltage with Low  $R_{DS(on)}$
- Easy to Parallel and Simple to Drive
- Resistant to Latch-Up
- Halogen Free, RoHS Compliant

### Benefits

- Higher System Efficiency
- Reduced Cooling Requirements
- Increased System Switching Frequency

### Applications

- Auxiliary Power Supplies
- Solar Inverters
- High Voltage DC/DC Converters
- High-frequency applications

$V_{DS}$	1200 V
$I_{D(MAX)}$ @ 25°C	17.7 A
$R_{DS(on)}$	160 mΩ

### Package

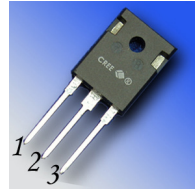

TO-247-3

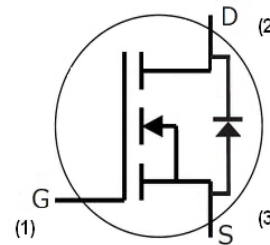

Part Number	Package
C2M0160120D	TO-247-3

### Maximum Ratings ( $T_C = 25^\circ\text{C}$ unless otherwise specified)

Symbol	Parameter	Value	Unit	Test Conditions	Note
$I_{DS(DC)}$	Continuous Drain Current	17.7	A	$V_{GS}@20\text{ V}, T_C = 25^\circ\text{C}$	Fig. 19
		11		$V_{GS}@20\text{ V}, T_C = 100^\circ\text{C}$	
$I_{DS(pulse)}$	Pulsed Drain Current	45	A	Pulse width $t_p = 50\ \mu\text{s}$ duty limited by $T_{jmax}, T_C = 25^\circ\text{C}$	
$V_{GS}$	Gate Source Voltage	-10/+25	V		
$P_{tot}$	Power Dissipation	125	W	$T_C=25^\circ\text{C}$	Fig. 20
$T_J, T_{stg}$	Operating Junction and Storage Temperature	-55 to +150	°C		
$T_L$	Solder Temperature	260	°C	1.6mm (0.063") from case for 10s	
$M_d$	Mounting Torque	1	Nm lbf-in	M3 or 6-32 screw	
		8.8			



## Electrical Characteristics (T<sub>C</sub> = 25°C unless otherwise specified)

Symbol	Parameter	Min.	Typ.	Max.	Unit	Test Conditions	Note
V <sub>(BR)DSS</sub>	Drain-Source Breakdown Voltage	1200			V	V <sub>GS</sub> = 0 V, I <sub>DS</sub> = 50 μA	
V <sub>GS(th)</sub>	Gate Threshold Voltage	2.0	2.5		V	V <sub>DS</sub> = 10V, I <sub>DS</sub> = 0.5 mA	Fig. 11
		1.5	1.9		V	V <sub>DS</sub> = 10V, I <sub>DS</sub> = 0.5 mA, T <sub>J</sub> = 150°C	
I <sub>DSS</sub>	Zero Gate Voltage Drain Current		1	100	μA	V <sub>DS</sub> = 1200 V, V <sub>GS</sub> = 0 V	
			10	250		V <sub>DS</sub> = 1200 V, V <sub>GS</sub> = 0 V T <sub>J</sub> = 150°C	
I <sub>GSS</sub>	Gate-Source Leakage Current			0.25	μA	V <sub>GS</sub> = 20 V, V <sub>DS</sub> = 0 V	
R <sub>DS(on)</sub>	Drain-Source On-State Resistance		160	196	mΩ	V <sub>GS</sub> = 20 V, I <sub>D</sub> = 10 A	Fig. 4, 5, 6
			290	400		V <sub>GS</sub> = 20 V, I <sub>D</sub> = 10A, T <sub>J</sub> = 150°C	
g <sub>fs</sub>	Transconductance		4.3		S	V <sub>DS</sub> = 20 V, I <sub>DS</sub> = 10 A	Fig. 7
			4.1			V <sub>DS</sub> = 20 V, I <sub>DS</sub> = 10 A, T <sub>J</sub> = 150°C	
C <sub>iss</sub>	Input Capacitance		527		pF	V <sub>GS</sub> = 0 V V <sub>DS</sub> = 800 V f = 1 MHz V <sub>AC</sub> = 25 mV	Fig. 16, 17
C <sub>oss</sub>	Output Capacitance		47				
C <sub>rss</sub>	Reverse Transfer Capacitance		4				
E <sub>oss</sub>	C <sub>oss</sub> Stored Energy		15				μJ
t <sub>d(on)v</sub>	Turn-On Delay Time		7		ns	V <sub>DD</sub> = 800 V, V <sub>GS</sub> = -5/20 V I <sub>D</sub> = 10 A R <sub>G(ext)</sub> = 0 Ω, R <sub>L</sub> = 40 Ω Timing relative to V <sub>DS</sub>	Fig. 27
t <sub>fv</sub>	Fall Time		7				
t <sub>d(off)v</sub>	Turn-Off Delay Time		13				
t <sub>rv</sub>	Rise Time		12				
R <sub>G</sub>	Internal Gate Resistance		6.5		Ω	f = 1 MHz, V <sub>AC</sub> = 25 mV	

## Built-in SiC Body Diode Characteristics

Symbol	Parameter	Typ.	Max.	Unit	Test Conditions	Note
V <sub>SD</sub>	Diode Forward Voltage	3.1		V	V <sub>GS</sub> = -5 V, I <sub>F</sub> = 5 A, T <sub>J</sub> = 25 °C	Fig 9, 10
		2.9			V <sub>GS</sub> = -2 V, I <sub>F</sub> = 5 A, T <sub>J</sub> = 150 °C	

## Thermal Characteristics

Symbol	Parameter	Typ.	Max.	Unit	Test Conditions	Note
R <sub>θJC</sub>	Thermal Resistance from Junction to Case	0.9	1.0	K/W		Fig. 21
R <sub>θCS</sub>	Case to Sink, w/ Thermal Compound	0.25				
R <sub>θJA</sub>	Thermal Resistance From Junction to Ambient		40			

## Gate Charge Characteristics

Symbol	Parameter	Typ.	Max.	Unit	Test Conditions	Note
Q <sub>gs</sub>	Gate to Source Charge	6.9		nC	V <sub>DS</sub> = 800 V, V <sub>GS</sub> = -5/20 V I <sub>D</sub> = 10 A Per JEDEC24 pg 27	Fig. 12
Q <sub>gd</sub>	Gate to Drain Charge	13.6				
Q <sub>g</sub>	Gate Charge Total	32.6				

## Typical Performance

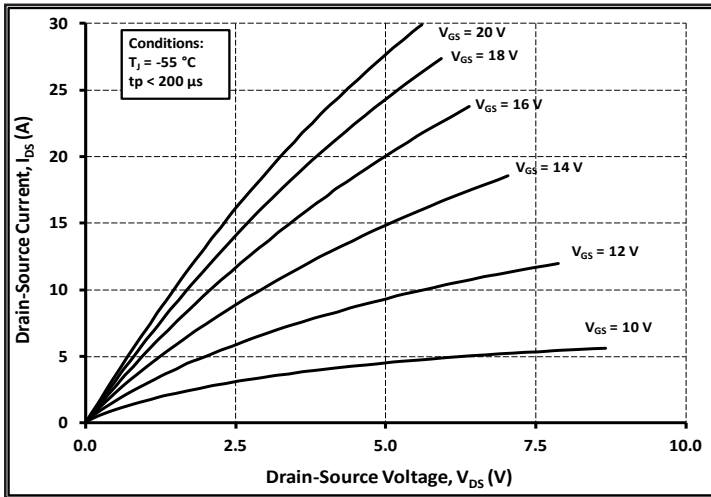

Figure 1. Typical Output Characteristics  $T_j = -55\text{ }^\circ\text{C}$

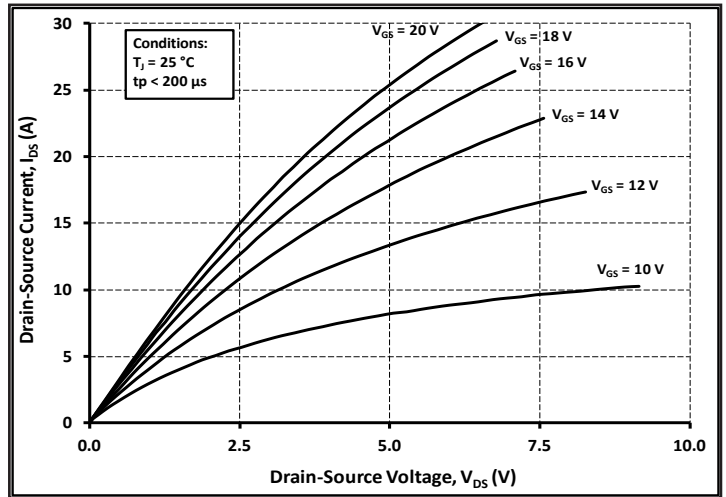

Figure 2. Typical Output Characteristics  $T_j = 25\text{ }^\circ\text{C}$

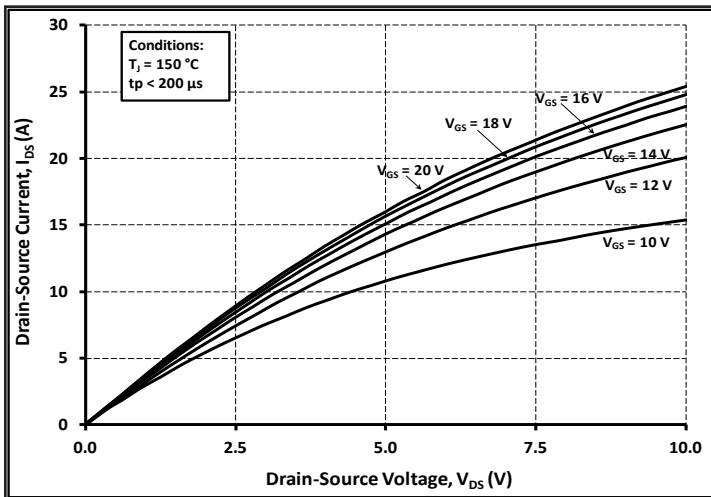

Figure 3. Typical Output Characteristics  $T_j = 150\text{ }^\circ\text{C}$

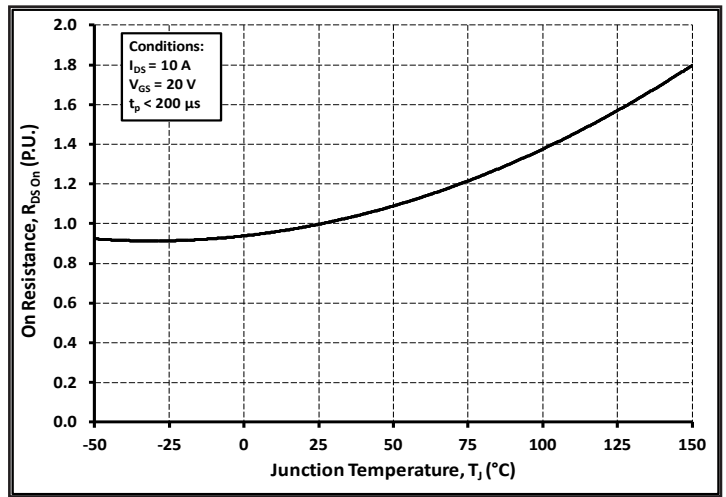

Figure 4. Normalized On-Resistance vs. Temperature

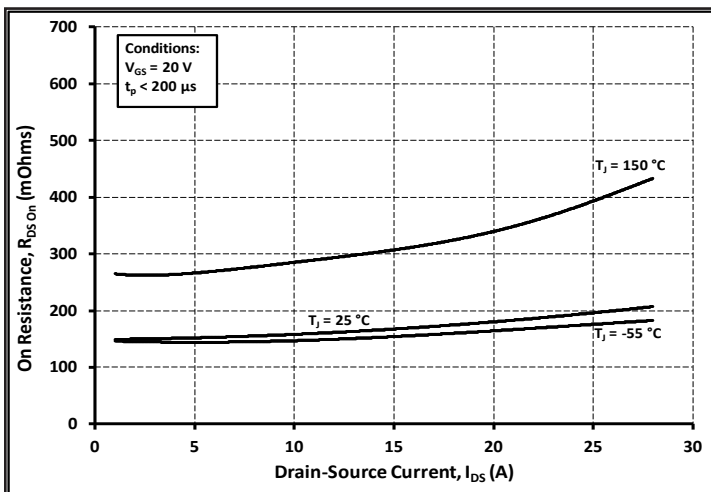

Figure 5. Typical On-Resistance vs. Drain Current For Various Temperatures

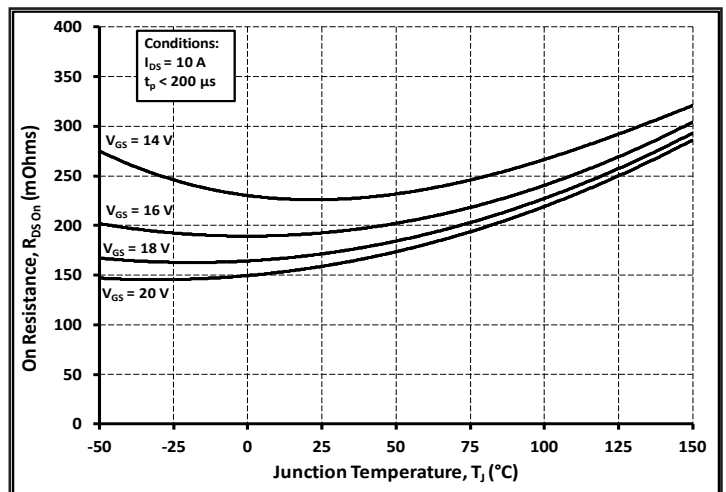

Figure 6. Typical On-Resistance vs. Temperature For Various Gate Voltage

# Typical Performance

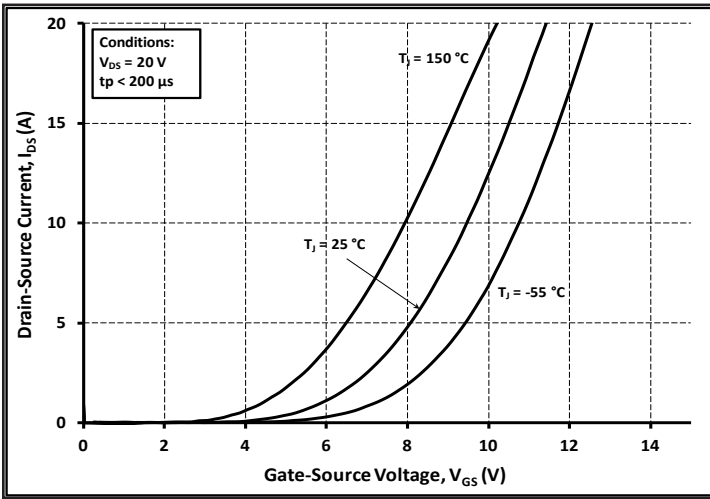

Figure 7. Typical Transfer Characteristic For Various Temperatures

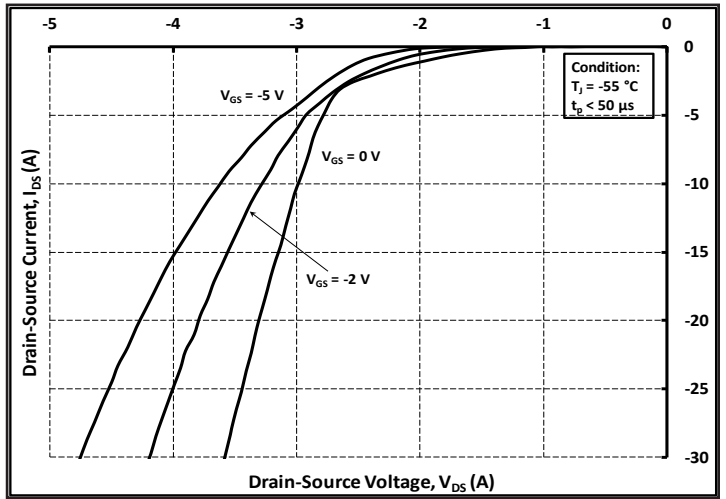

Figure 8. Typical Body Diode Characteristic  $T_J = -55\text{ }^\circ\text{C}$

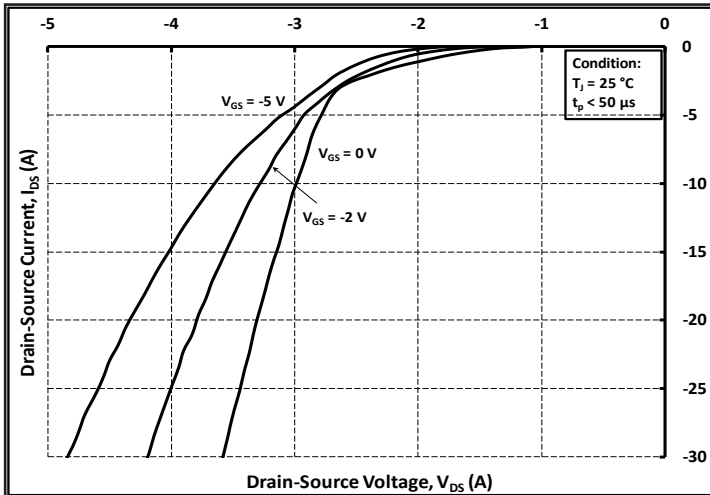

Figure 9. Typical Body Diode Characteristic  $T_J = 25\text{ }^\circ\text{C}$

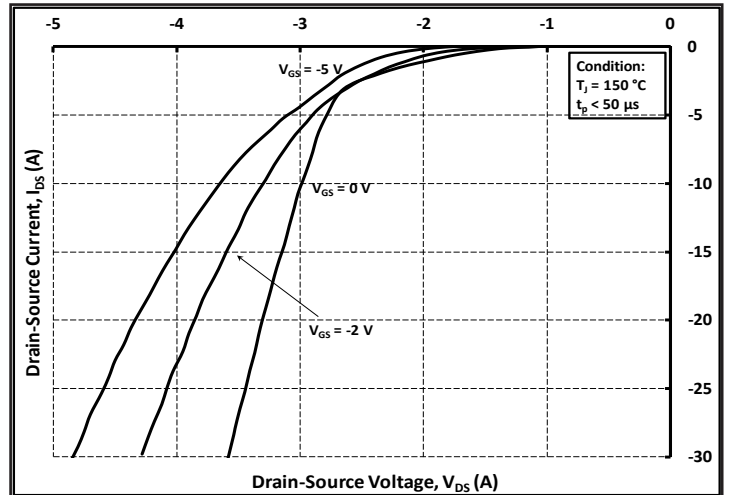

Figure 10. Typical Body Diode Characteristic  $T_J = 150\text{ }^\circ\text{C}$

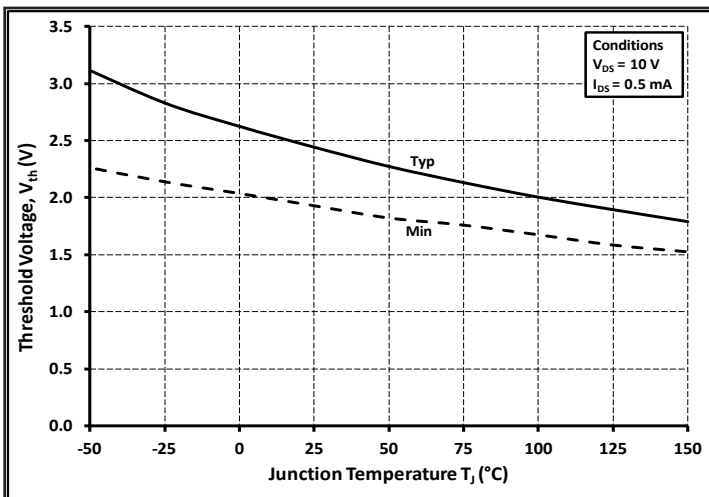

Figure 11. Typical and Minimum Threshold Voltage vs. Temperature

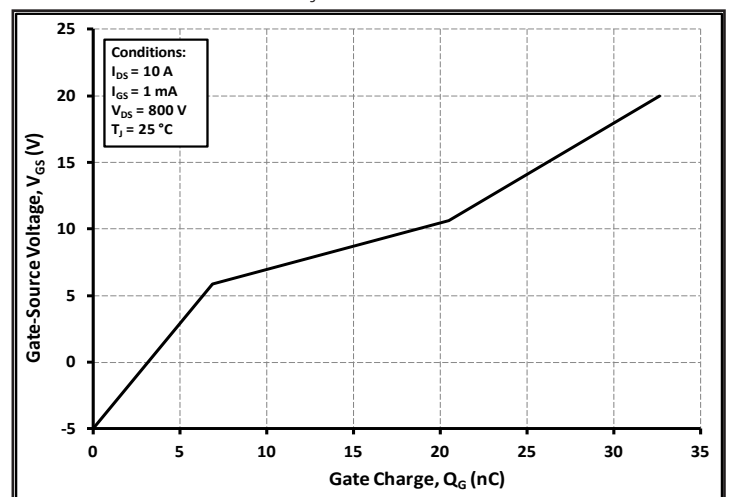

Figure 12. Typical Gate Charge Characteristic 25 °C

# Typical Performance

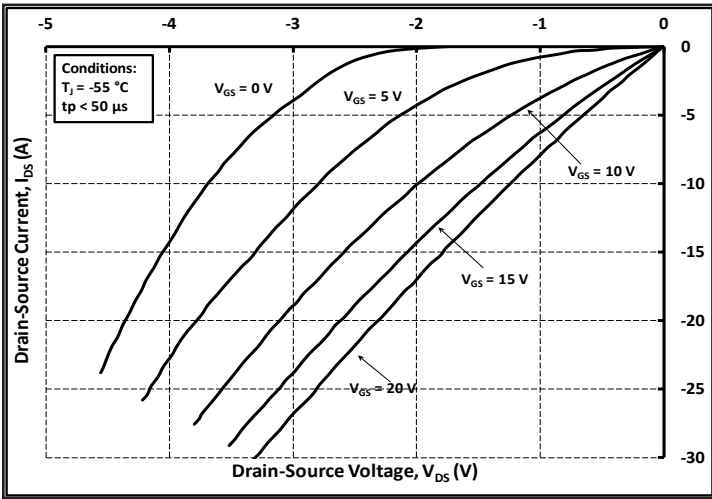

Figure 13. Typical 3rd Quadrant Characteristic  
 $T_j = -55\text{ }^\circ\text{C}$

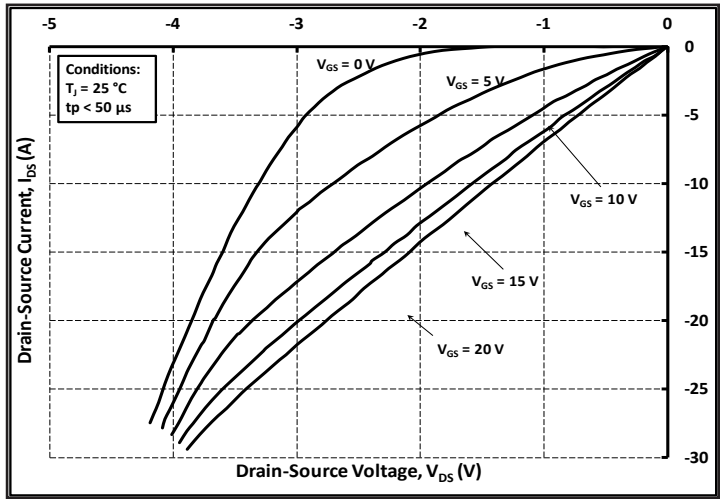

Figure 14. Typical 3rd Quadrant Characteristic  
 $T_j = 25\text{ }^\circ\text{C}$

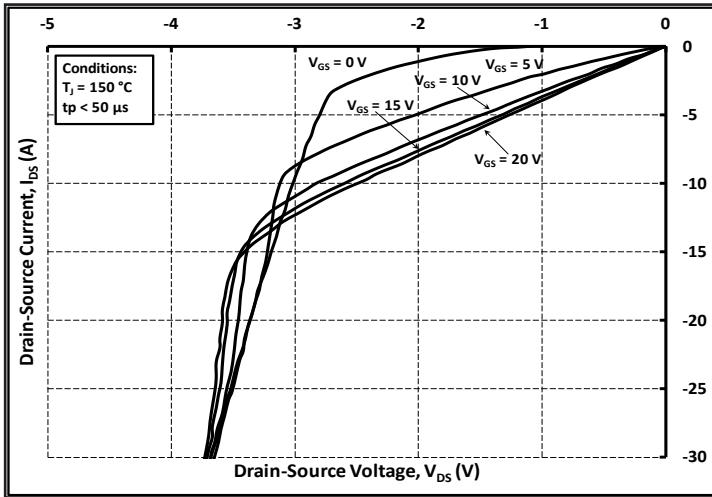

Figure 15. Typical 3rd Quadrant Characteristic  
 $T_j = 150\text{ }^\circ\text{C}$

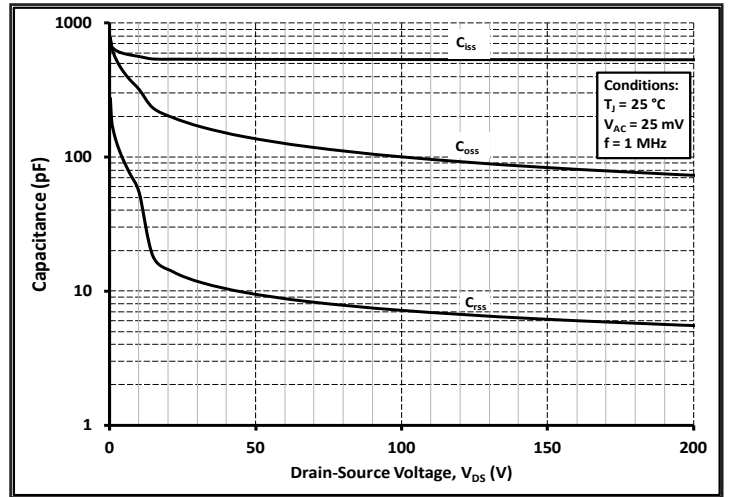

Figure 16. Typical Typical Capacitances vs. Drain-Source Voltage (0 - 200V)

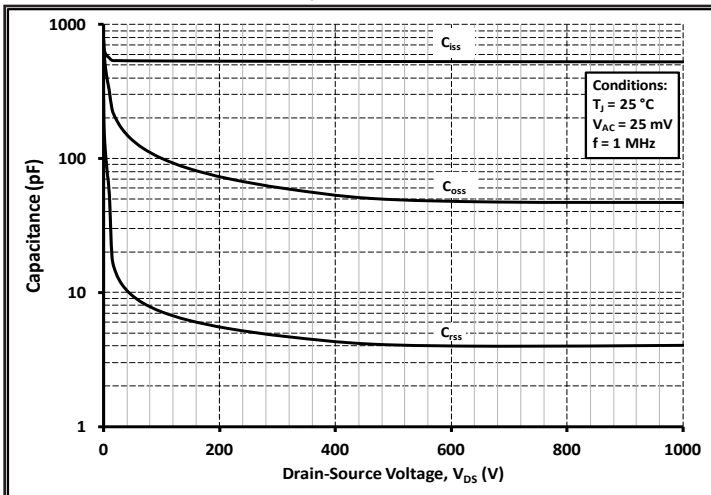

Figure 17. Typical Typical Capacitances vs. Drain-Source Voltage (0 - 1000V)

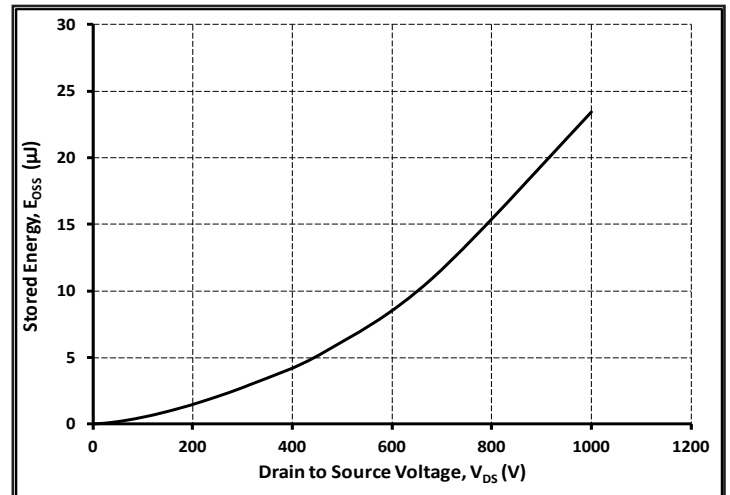

Figure 18. Stored Energy  $C_{oss}$

# Typical Performance

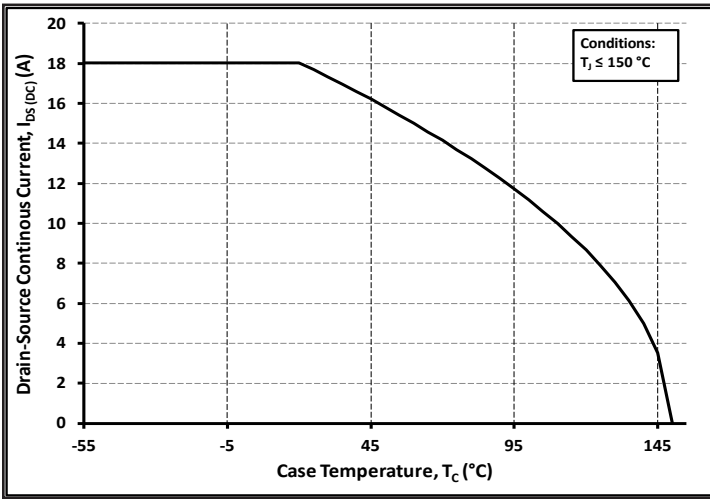

Figure 19. Continuous Current Derating Curve

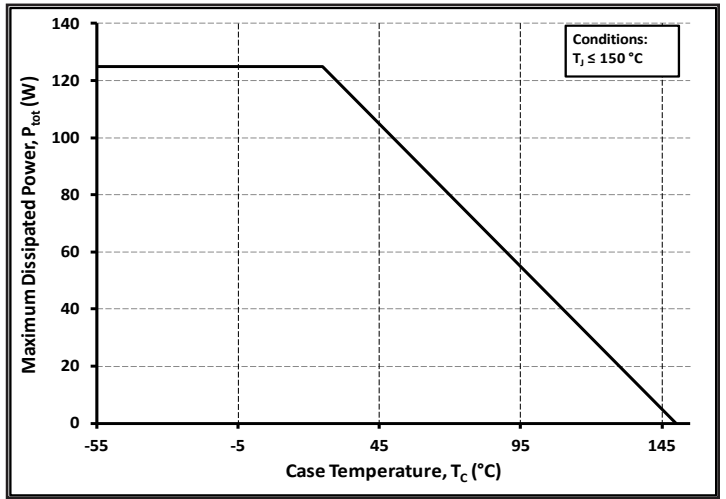

Figure 20. Continuous Power Derating

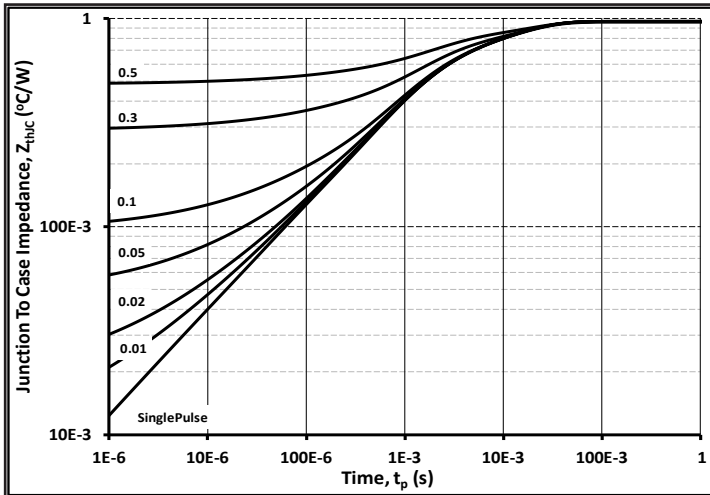

Figure 21. Typical Transient Thermal Impedance (Junction - Case)

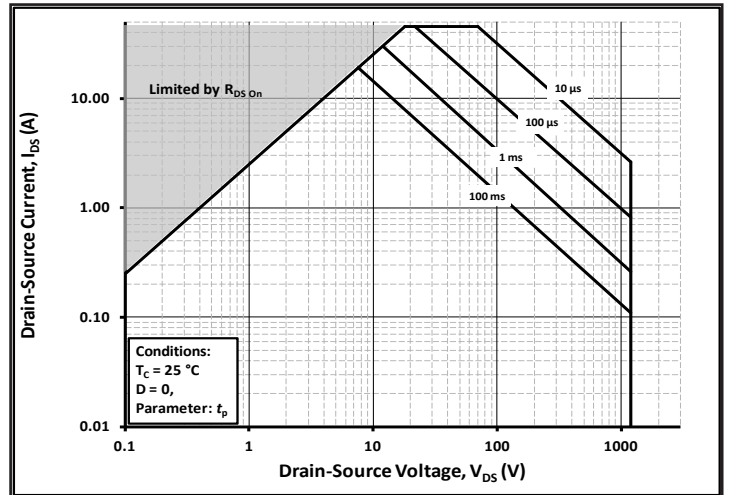

Figure 22. Safe Operating Area

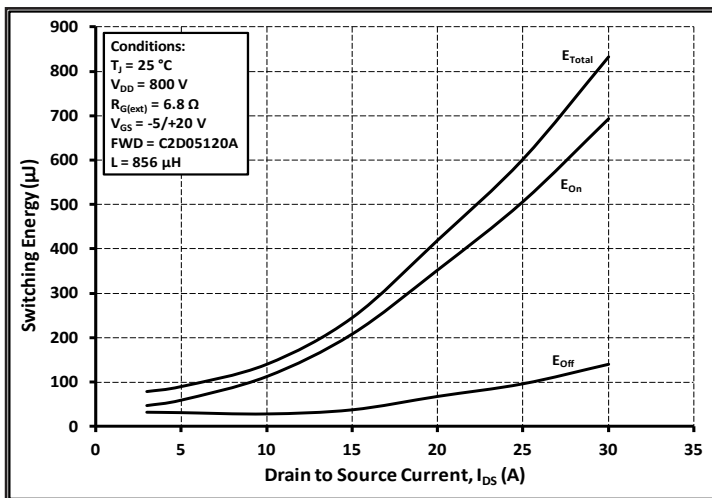

Figure 23. Clamped Inductive Switching Energy vs. Drain Current ( $V_{DS} = 800 \text{ V}$ )

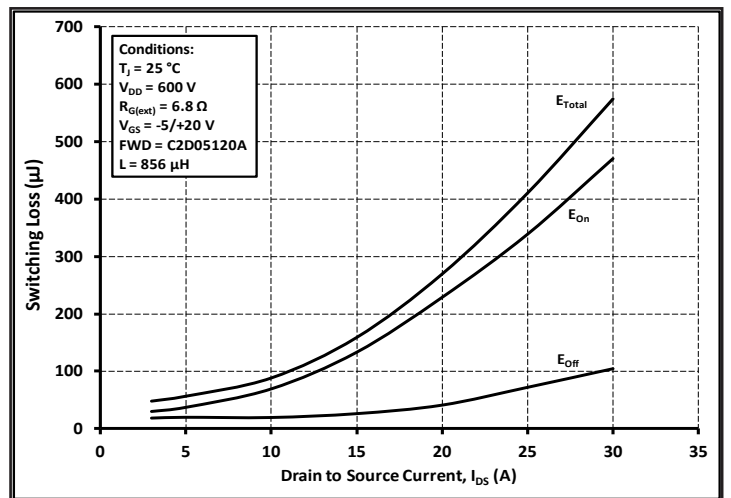

Figure 24. Clamped Inductive Switching Energy vs. Drain Current ( $V_{DS} = 600 \text{ V}$ )

# Typical Performance

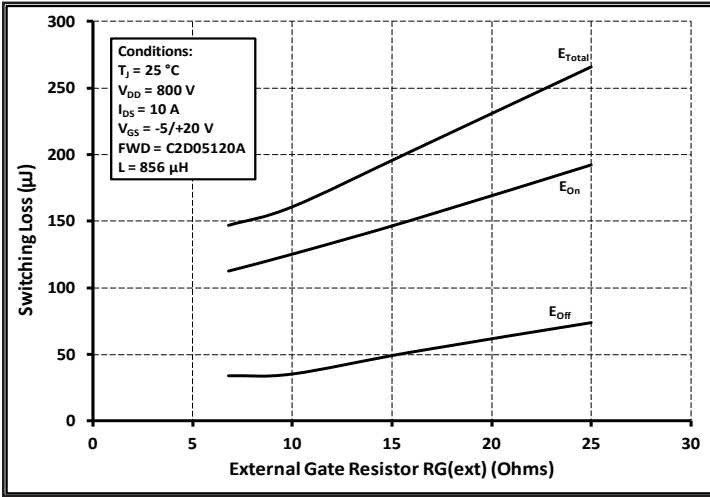

Figure 25. Clamped Inductive Switching Energy vs.  $R_{G(ext)}$

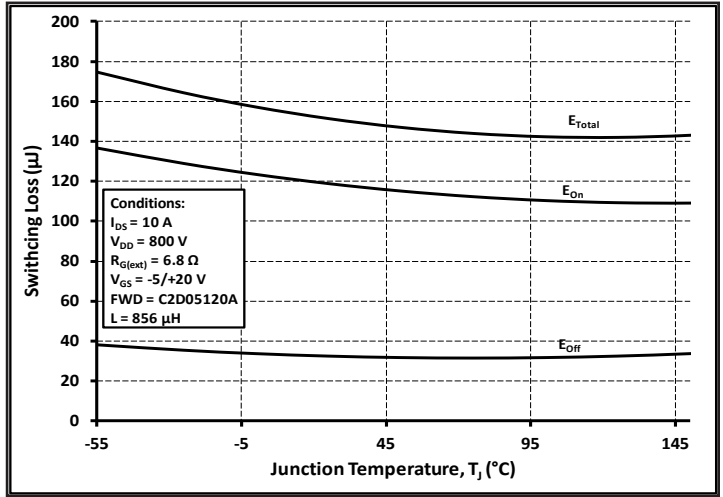

Figure 26. Clamped Inductive Switching Energy vs. Junction Temperature

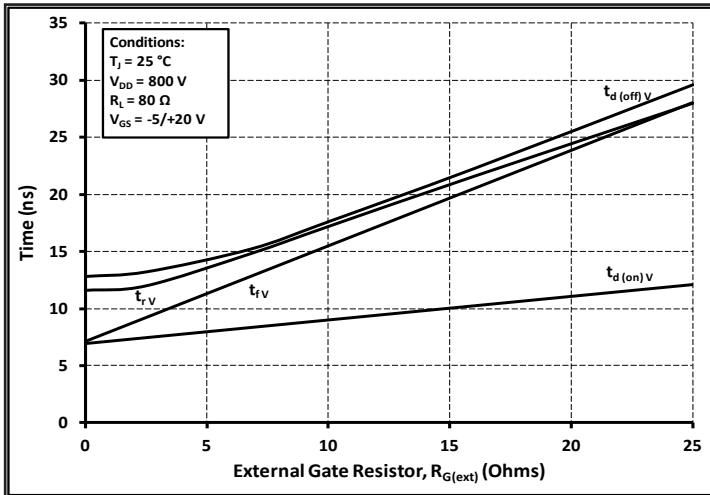

Figure 27. Resistive Switching Times vs. External Gate Resistor ( $V_{DD} = 800V, I_D = 10A$ )

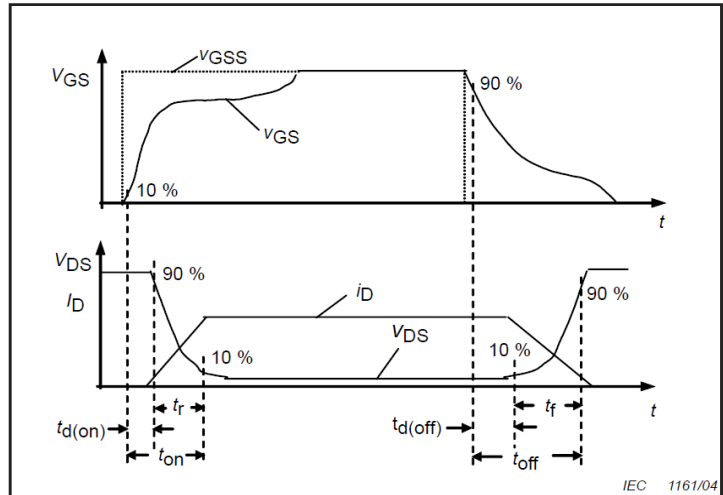

Figure 28. Resistive Switching Time Description

## Clamped Inductive Switching Fixture and Waveforms

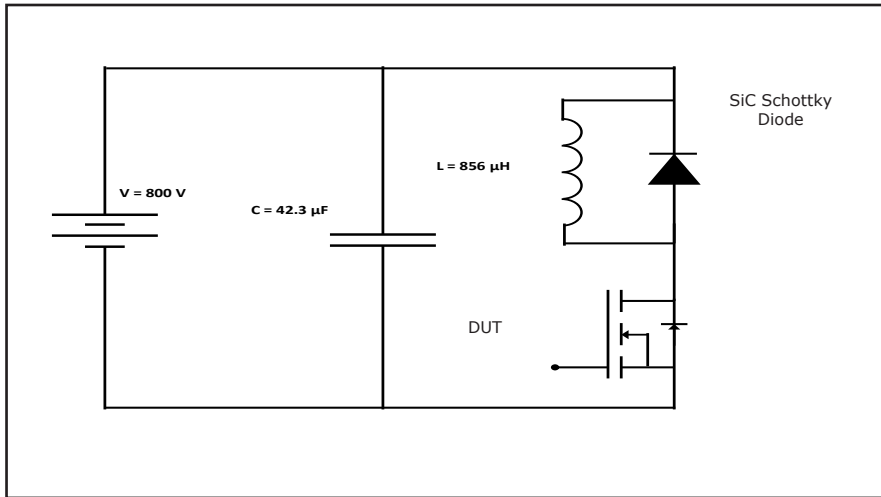

Figure 29. Clamped Inductive Switching Waveform Test Circuit

## ESD Ratings

ESD Test	Total Devices Sampled	Resulting Classification
ESD-HBM	All Devices Passed 1000V	2 (>2000V)
ESD-MM	All Devices Passed 400V	C (>400V)
ESD-CDM	All Devices Passed 1000V	IV (>1000V)



## Package Dimensions

Package TO-247-3

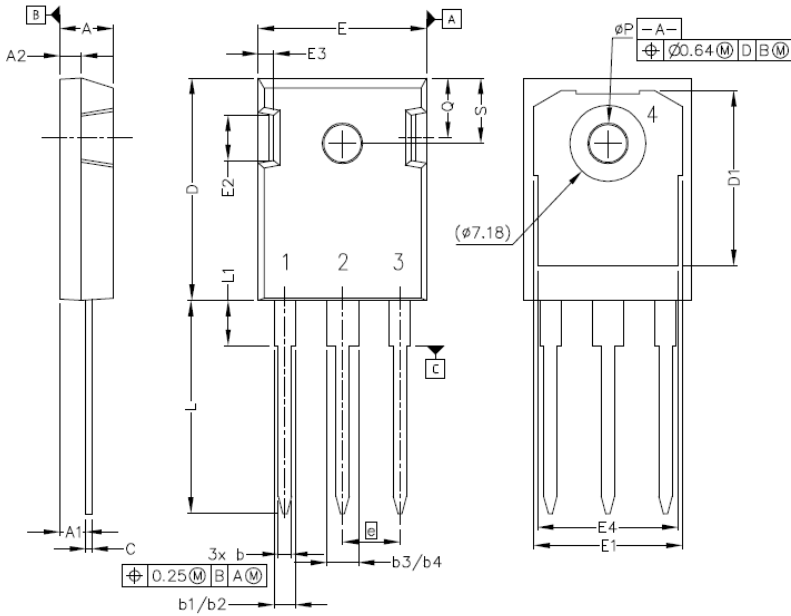

POS	Inches		Millimeters	
	Min	Max	Min	Max
A	.190	.205	4.83	5.21
A1	.090	.100	2.29	2.54
A2	.075	.085	1.91	2.16
b	.042	.052	1.07	1.33
b1	.075	.095	1.91	2.41
b2	.075	.085	1.91	2.16
b3	.113	.133	2.87	3.38
b4	.113	.123	2.87	3.13
c	.022	.027	0.55	0.68
D	.819	.831	20.80	21.10
D1	.640	.695	16.25	17.65
D2	.037	.049	0.95	1.25
E	.620	.635	15.75	16.13
E1	.516	.557	13.10	14.15
E2	.145	.201	3.68	5.10
E3	.039	.075	1.00	1.90
E4	.487	.529	12.38	13.43
e	.214 BSC		5.44 BSC	
N	3		3	
L	.780	.800	19.81	20.32
L1	.161	.173	4.10	4.40
ØP	.138	.144	3.51	3.65
Q	.216	.236	5.49	6.00
S	.238	.248	6.04	6.30

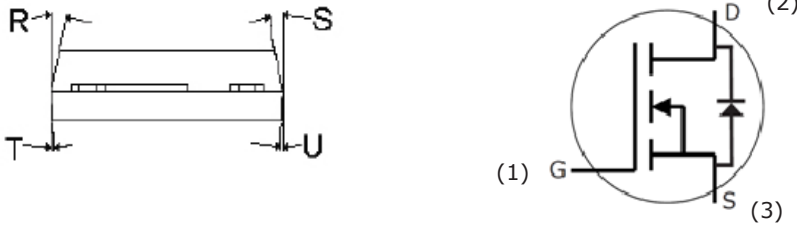

## Recommended Solder Pad Layout

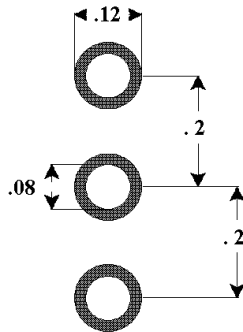

TO-247-3

Part Number	Package	Marking
C2M0160120D	TO-247-3	C2M0160120

This product has not been designed or tested for use in, and is not intended for use in, applications implanted into the human body nor in applications in which failure of the product could lead to death, personal injury or property damage, including but not limited to equipment used in the operation of nuclear facilities, life-support machines, cardiac defibrillators or similar emergency medical equipment, aircraft navigation or communication or control systems, air traffic control systems, or weapons systems.

Copyright © 2013 Cree, Inc. All rights reserved. The information in this document is subject to change without notice. Cree and the Cree logo are registered trademarks and Z-REC and Z-FET are trademarks of Cree, Inc.

Cree, Inc.  
4600 Silicon Drive  
Durham, NC 27703  
USA Tel: +1.919.313.5300  
Fax: +1.919.313.5451  
www.cree.com/power