



General Description

AFP8803, P-Channel enhancement mode MOSFET, uses Advanced Trench Technology to provide excellent $R_{DS(ON)}$, low gate charge.

These devices are particularly suited for low voltage power management, and low in-line power loss are needed in commercial industrial surface mount applications.

Features

- -20V/-5.4A, $R_{DS(ON)}=32m\Omega@V_{GS}=4.5V$
- -20V/-4.0A, $R_{DS(ON)}=42m\Omega@V_{GS}=2.5V$
- -20V/-3.0A, $R_{DS(ON)}=58m\Omega@V_{GS}=1.8V$
- Super high density cell design for extremely low $R_{DS(ON)}$
- TSSOP-8P package design

Pin Description (TSSOP-8P)

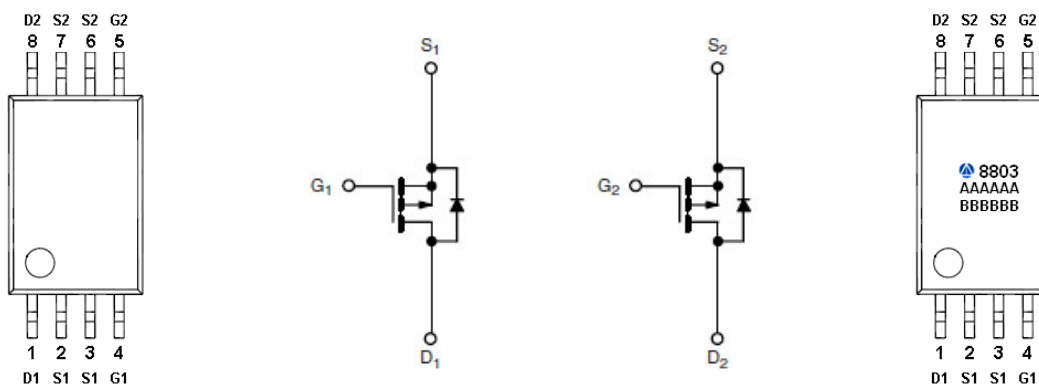

Application

- Load Switch
- Portable Equipment
- Battery Powered System

Pin Define

Pin	Symbol	Description
1	D1 / D2	Drain
2	S1	Source
3	S1	Source
4	G1	Gate
5	G2	Gate
6	S2	Source
7	S2	Source
8	D1 / D2	Drain

Ordering Information

Part Ordering No.	Part Marking	Package	Unit	Quantity
AFP8803TS8RG	8803	TSSOP-8P	Tape & Reel	3000 EA

※ A Lot code

※ B Date code

※ AFP8803TS8RG : 13" Tape & Reel ; Pb- Free ; Halogen- Free



Absolute Maximum Ratings

($T_A=25^\circ\text{C}$ Unless otherwise noted)

Parameter	Symbol	Typical	Unit
Drain-Source Voltage	V_{DSS}	-20	V
Gate –Source Voltage	V_{GSS}	± 12	V
Continuous Drain Current($T_J=150^\circ\text{C}$)	I_D	$T_A=25^\circ\text{C}$	-4.8
		$T_A=70^\circ\text{C}$	-3.0
Pulsed Drain Current	I_{DM}	-20	A
Continuous Source Current(Diode Conduction)	I_S	-1.5	A
Power Dissipation	P_D	$T_A=25^\circ\text{C}$	2.8
		$T_A=70^\circ\text{C}$	1.8
Operating Junction Temperature	T_J	150	$^\circ\text{C}$
Storage Temperature Range	T_{STG}	-55/150	$^\circ\text{C}$
Thermal Resistance-Junction to Ambient	$R_{\theta JA}$	62.5	$^\circ\text{C/W}$

Electrical Characteristics

($T_A=25^\circ\text{C}$ Unless otherwise noted)

Parameter	Symbol	Conditions	Min.	Typ	Max.	Unit
Static						
Drain-Source Breakdown Voltage	$V_{(BR)DSS}$	$V_{GS}=0V, I_D=-250\mu\text{A}$	-20			V
Gate Threshold Voltage	$V_{GS(th)}$	$V_{DS}=V_{GS}, I_D=-250\mu\text{A}$	-0.4		-0.9	
Gate Leakage Current	I_{GSS}	$V_{DS}=0V, V_{GS}=\pm 12V$			± 100	nA
Zero Gate Voltage Drain Current	I_{DSS}	$V_{DS}=-16V, V_{GS}=0V$			-1	uA
		$V_{DS}=-16V, V_{GS}=0V$ $T_J=85^\circ\text{C}$			-10	
On-State Drain Current	$I_{D(on)}$	$V_{DS} \geq -5V, V_{GS}=-4.5V$	-6			A
		$V_{DS} \geq -5V, V_{GS}=-2.5V$	-4			
Drain-Source On-Resistance	$R_{DS(on)}$	$V_{GS}=-4.5V, I_D=-5.4A$		23	32	m Ω
		$V_{GS}=-2.5V, I_D=-4.0A$		30	42	
		$V_{GS}=-1.8V, I_D=-3.0A$		40	58	
Forward Transconductance	g_{FS}	$V_{DS}=-5V, I_D=-3.6A$		10		S
Diode Forward Voltage	V_{SD}	$I_S=-1.6A, V_{GS}=0V$		-0.85	-1.2	V
Dynamic						
Total Gate Charge	Q_g	$V_{DS}=-10V, V_{GS}=-4.5V$ $I_D=-4.0A$		15	25	nC
Gate-Source Charge	Q_{gs}			2.5		
Gate-Drain Charge	Q_{gd}			3.5		
Input Capacitance	C_{iss}	$V_{DS}=-10V, V_{GS}=0V$ $f=1\text{MHz}$		1050		pF
Output Capacitance	C_{oss}			165		
Reverse Transfer Capacitance	C_{rss}			125		
Turn-On Time	$t_{d(on)}$	$V_{DD}=-10V, R_L=10\Omega$ $I_D=-2.0A, V_{GEN}=-4.5V$ $R_G=6\Omega$		35	55	ns
	t_r			60	85	
Turn-Off Time	$t_{d(off)}$			120	180	
	t_f			55	85	



Typical Characteristics

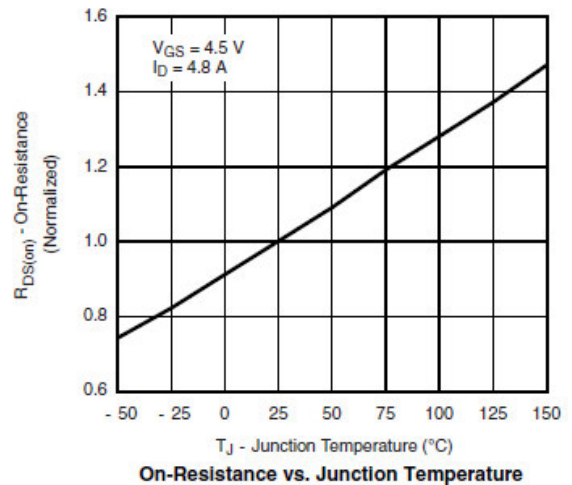
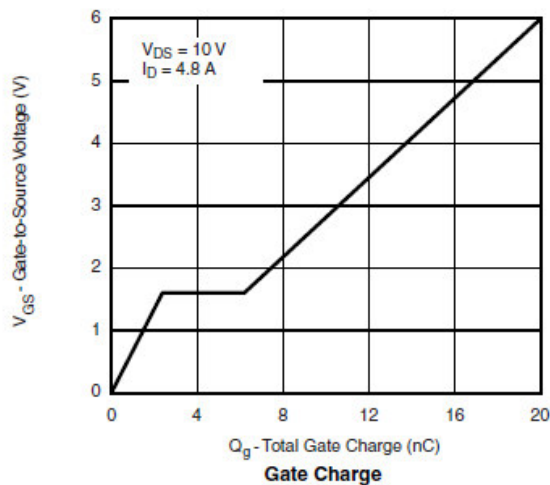
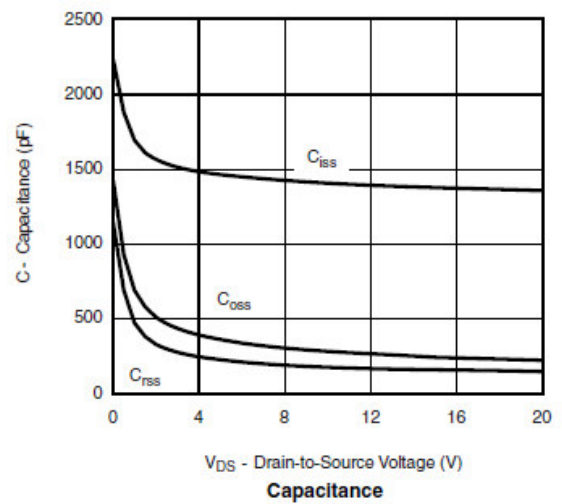
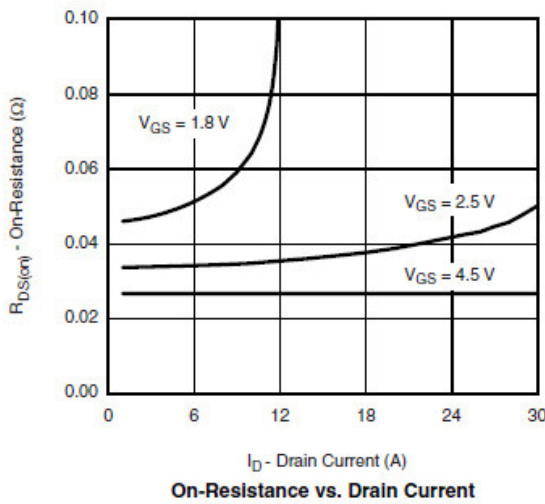
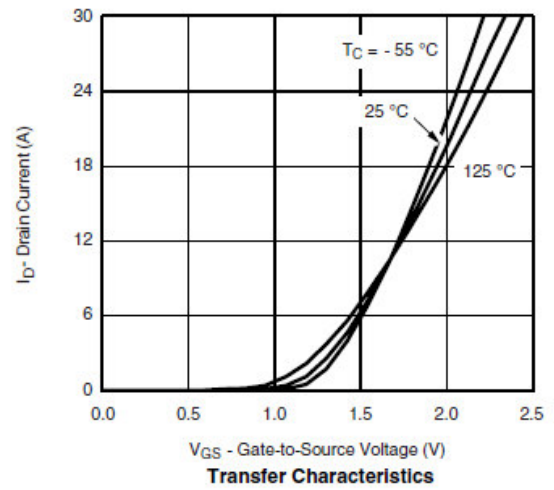
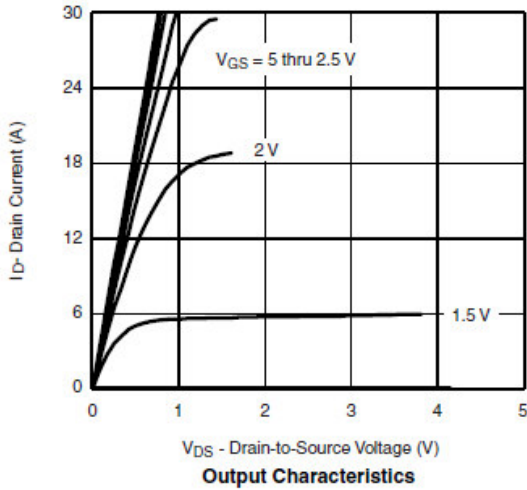



Typical Characteristics

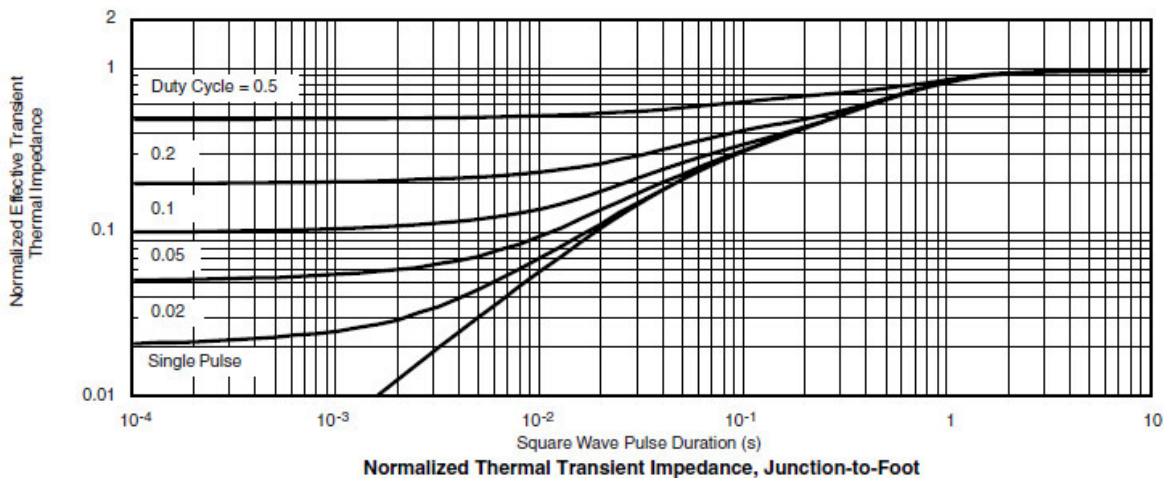
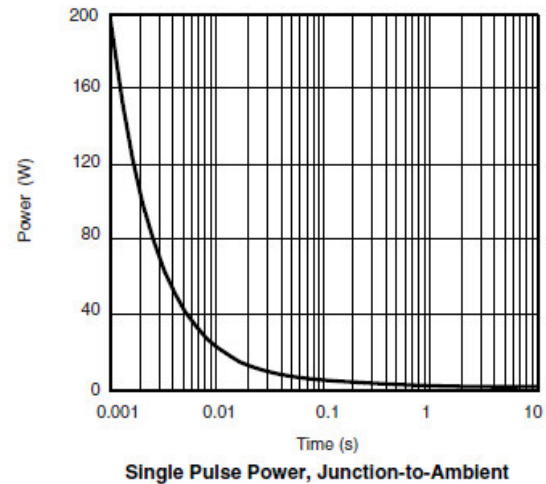
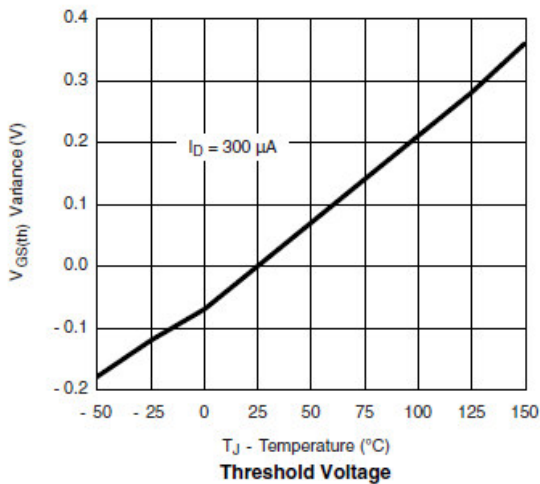
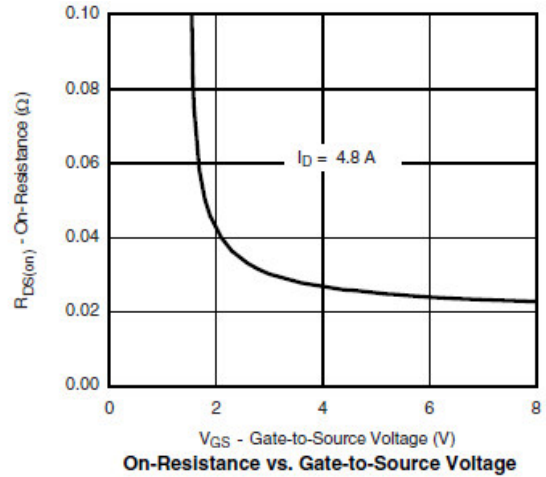
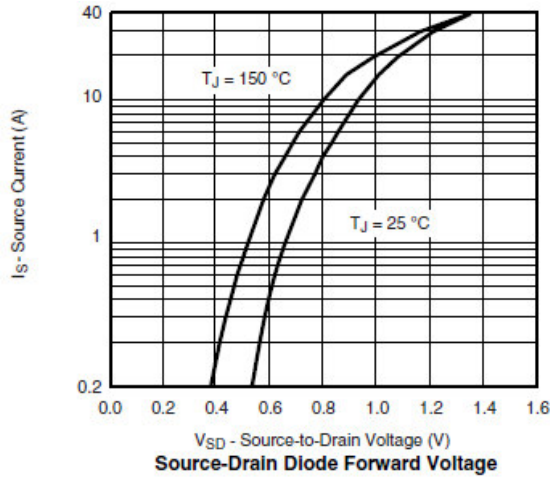



Typical Characteristics

Gate Charge Test Circuit & Waveform

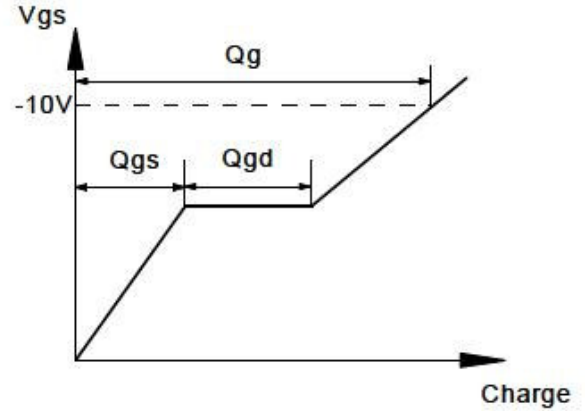
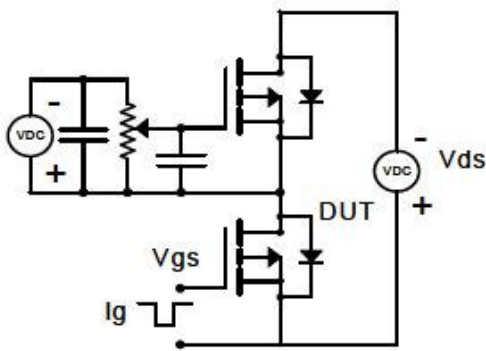

Resistive Switching Test Circuit & Waveforms

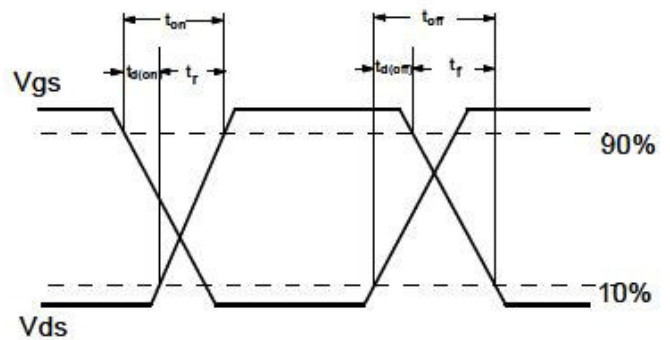
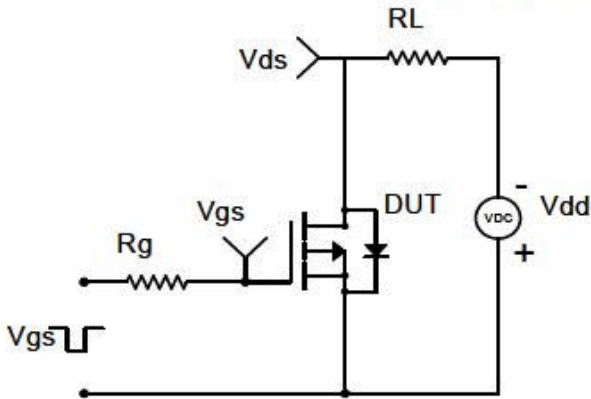

Diode Recovery Test Circuit & Waveforms

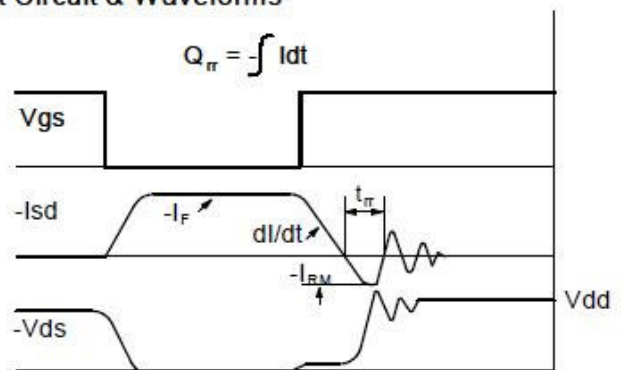
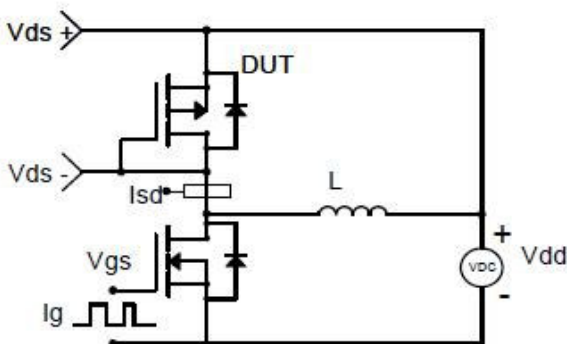



Package Information (TSSOP-8P)

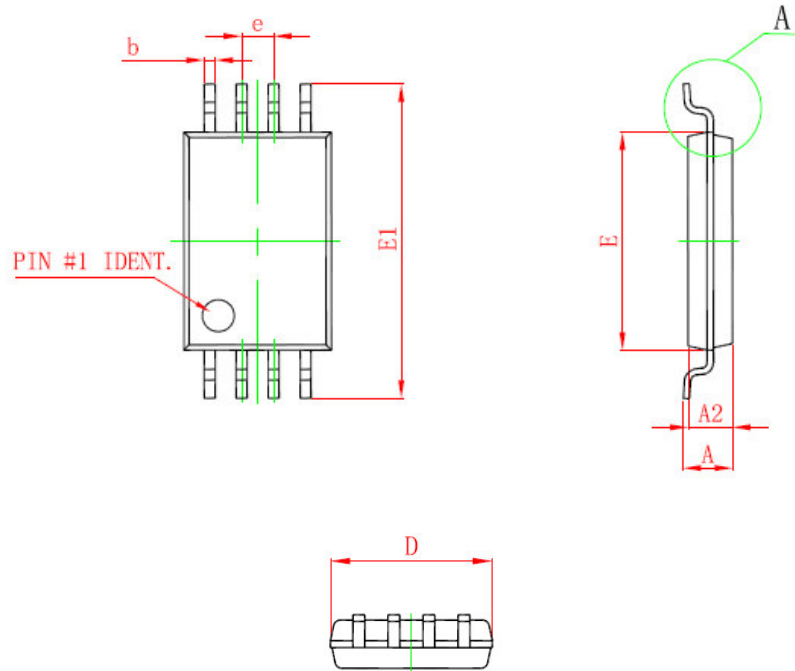

Symbol	Dimensions In Millimeters		Dimensions In Inches	
	Min	Max	Min	Max
D	2.900	3.100	0.114	0.122
E	4.300	4.500	0.169	0.177
b	0.190	0.300	0.007	0.012
c	0.090	0.200	0.004	0.008
E1	6.250	6.550	0.246	0.258
A		1.100		0.043
A2	0.800	1.000	0.031	0.039
A1	0.020	0.150	0.001	0.006
e	0.65 (BSC)		0.026 (BSC)	
L	0.500	0.700	0.020	0.028
H	0.25 (TYP)		0.01 (TYP)	
θ	1°	7°	1°	7°

©2010 Alfa-MOS Technology Corp.
 2F, No.80, Sec.1, Cheng Kung Rd., Nan Kang Dist., Taipei City 115, Taiwan (R.O.C.)
 Tel : 886 2) 2651 3928
 Fax : 886 2) 2786 8483
 ©http://www.alfa-mos.com