

**VOIDLESS-HERMETICALLY SEALED  
SURFACE MOUNT FAST RECOVERY  
GLASS RECTIFIERS**

**DESCRIPTION**

This "fast recovery" rectifier diode series is ideal for high-reliability applications where a failure cannot be tolerated. These industry-recognized 3.0 Amp rated rectifiers for working peak reverse voltages from 100 to 600 volts are hermetically sealed with voidless-glass construction using an internal "Category I" metallurgical bond. These devices are also available in military qualified axial-leaded packages by deleting the "US" suffix. Microsemi also offers numerous other rectifier products to meet higher and lower current ratings with various recovery time speed requirements including fast and ultrafast device types in both through-hole and surface mount packages.

**APPEARANCE**

**Package "E"  
or D-5B**

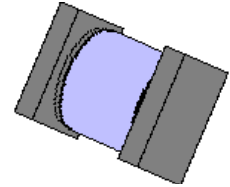

**IMPORTANT:** For the most current data, consult MICROSEMI's website: <http://www.microsemi.com>

**FEATURES**

- Surface mount equivalent to the popular JEDEC registered 1N5186 to 1N5190 series
- Voidless hermetically sealed glass package
- Triple-Layer Passivation
- Internal "Category I" Metallurgical bonds
- Working Peak Reverse Voltage 100 to 600 Volts.
- Further options in screening in accordance with MIL-PRF-19500/424 for JAN, JANTX, and JANTXV by adding a MQ, MX, or MV prefix respectively, e.g. MX1N5186US, MV1N5187US, etc.
- Axial-leaded package equivalents also available (see separate data sheet for 1N5186 thru 1N5190)

**APPLICATIONS / BENEFITS**

- Fast recovery 3 Amp rectifiers 100 to 600 V
- Military and other high-reliability applications
- General rectifier applications including bridges, half-bridges, catch diodes, etc.
- High forward surge current capability
- Extremely robust construction
- Low thermal resistance
- Controlled avalanche with peak reverse power capability
- Inherently radiation hard as described in Microsemi MicroNote 050

**MAXIMUM RATINGS**

- Junction & Storage Temperature: -65°C to +175°C
- Thermal Resistance: 10°C/W junction to end cap
- Thermal Impedance: 1.5°C/W @ 10 ms heating time
- Average Rectified Forward Current (I<sub>O</sub>): 3.0 Amps @ T<sub>A</sub> = 25°C and 0.700 Amps at T<sub>A</sub> = 150°C
- Forward Surge Current: 80 Amps @ 8.3 ms half-sine
- Solder Temperatures: 260°C for 10 s (maximum)

**MECHANICAL AND PACKAGING**

- CASE: Hermetically sealed voidless hard glass with Tungsten slugs
- TERMINATIONS: End caps are Copper with Tin/Lead (Sn/Pb) finish. Note: Previous inventory had solid Silver end caps with Tin/Lead (Sn/Pb) finish.
- MARKING: Cathode band only
- POLARITY: Cathode indicated by band
- TAPE & REEL option: Standard per EIA-481-B
- WEIGHT: 539 mg
- See package dimensions on last page

**ELECTRICAL CHARACTERISTICS**

| TYPE     | WORKING PEAK REVERSE VOLTAGE | MINIMUM BREAKDOWN VOLTAGE | FORWARD VOLTAGE              |           | MAXIMUM REVERSE CURRENT           |          | MAXIMUM REVERSE RECOVERY TIME | AVERAGE RECTIFIED CURRENT AMPS |            |
|----------|------------------------------|---------------------------|------------------------------|-----------|-----------------------------------|----------|-------------------------------|--------------------------------|------------|
|          | V <sub>RWM</sub>             | V <sub>BR</sub> @ 50μA    | V <sub>F</sub> @ 9A (pulsed) |           | I <sub>R</sub> @ V <sub>RWM</sub> |          | t <sub>rr</sub>               | I <sub>O</sub>                 |            |
|          | VOLTS                        | VOLTS                     | MIN VOLTS                    | MAX VOLTS | 25°C μA                           | 100°C μA | ns                            | 25°C AMPS                      | 150°C AMPS |
| 1N5186US | 100V                         | 120V                      | 0.9V                         | 1.5V      | 2.0                               | 100      | 150                           | 3.0                            | 0.7        |
| 1N5187US | 200V                         | 240V                      |                              |           |                                   |          |                               | 3.0                            | 0.7        |
| 1N5188US | 400V                         | 480V                      |                              |           |                                   |          |                               | 3.0                            | 0.7        |
| 1N5189US | 500V                         | 550V                      |                              |           |                                   |          |                               | 3.0                            | 0.7        |
| 1N5190US | 600V                         | 660V                      |                              |           |                                   |          |                               | 3.0                            | 0.7        |
|          |                              |                           |                              |           |                                   |          |                               | 400                            | 3.0        |

**SYMBOLS & DEFINITIONS**

| Symbol    | Definition  |
|-----------|---|
| $V_{BR}$  | Minimum Breakdown Voltage: The minimum voltage the device will exhibit at a specified current.  |
| $V_{RWM}$ | Working Peak Reverse Voltage: The maximum peak voltage that can be applied over the operating temperature range.  |
| $V_F$     | Maximum Forward Voltage: The maximum forward voltage the device will exhibit at a specified current.  |
| $I_R$     | Maximum Leakage Current: The maximum leakage current that will flow at the specified voltage and temperature.   |
| $t_{rr}$  | Reverse Recovery Time: The time interval between the instant the current passes through zero when changing from the forward direction to the reverse direction and a specified decay point after a peak reverse current occurs. |

**PACKAGE DIMENSIONS**

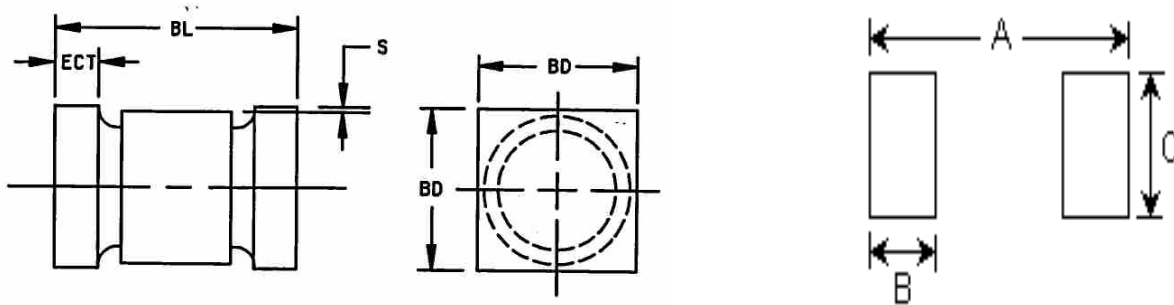

NOTE: This Package Outline has also previously been identified as "D-5B"

**PAD LAYOUT**

|     | INCHES |      | mm   |       |
|-----|--------|------|------|-------|
|     | MIN    | MAX  | MIN  | MAX   |
| BL  | .205   | .225 | 5.21 | 5.72  |
| BD  | .137   | .142 | 3.48 | 3.61  |
| ECT | .019   | .028 | 0.48 | 0.711 |
| S   | .003   | ---  | 0.08 | ---   |

|  | INCHES |     | mm   |     |
|--|--------|-----|------|-----|
|  | MIN    | MAX | MIN  | MAX |
| A  | 0.288  | --- | 7.32 | --- |
| B  | 0.070  | --- | 1.78 | --- |
| C  | 0.155  | --- | 3.94 | --- |
| Note: If mounting requires adhesive separate from the solder, an additional 0.080 inch diameter contact may be placed in the center between the pads as an optional spot for cement. |        |     |      |     |