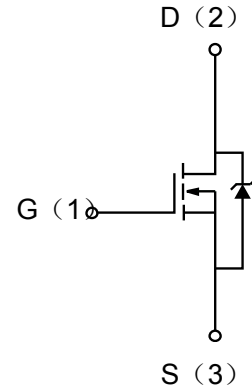

Description

The enhancement mode MOS is extremely high density cell and low on-resistance.

MOSFET Product Summary		
$V_{DS}(V)$	$R_{DS(on)}(\Omega)$	$I_D(A)$
600	0.98@ $V_{GS}=10V$	8.0

Absolute maximum rating@25°C

Rating	Symbol	PNMTO6 00V8	PNMTOF 600V8	Units	
Drain-Source Voltage	V_{DS}	600		V	
Gate-Source Voltage	V_{GS}	± 30		V	
Continuous Drain Current	I_D	8		A	
Total Power Dissipation	$T_A=25^\circ C$	P_D	166	40	W
	Derate above 25°C	P_D	1.82	0.40	W / °C
Junction and Storage Temperature Range	T_J, T_{STG}	-50 to 150		°C	
Maximum lead temperature for soldering purpose, 1/8" from case for 5 seconds	T_L	300		°C	

Thermal Characteristics

Parameter	Symbol	Conditions	PNMTO 600V8	PNMTO F600V8	Units
Maximum Junction-to-Ambient	$R_{\theta JA}$	Drain lead soldered to water cooled heatsink, P_D adjusted for a peak junction temperature of +150°C	62	100	°C/W
Maximum Junction-to-Case	$R_{\theta JC}$	1 cubic foot chamber, free air.	0.75	3.1	°C/W

Electrical characteristics per line @ 25 °C (unless otherwise specified)

Parameter	Symbol	Conditions	Min.	Typ.	Max.	Units
STATIC PARAMETERS						
Drain-Source Breakdown Voltage	BV_{DSS}	$I_D = 250\mu A, V_{GS} = 0V$	600		-	V
Zero Gate Voltage Drain Current	I_{DSS}	$V_{DS} = 600V, V_{GS} = 0V$	-	-	25	μA
Gate-Body Leakage Current	I_{GSS}	$V_{DS} = 0V, V_{GS} = \pm 30V$	-	-	± 100	nA
Gate Threshold Voltage	$V_{GS(th)}$	$V_{DS} = V_{GS}, I_D = 250\mu A$	2		4	V
Static Drain-Source On-Resistance	$R_{DS(ON)}$	$V_{GS} = 10V, I_D = 4.8A$	-	0.98	1.15	Ω
Forward Transconductance	g_{FS}	$V_{DS} = 15V, I_D = 8A$		9.37		S
Diode Forward Voltage	V_{SD}	$I_S = 8A, V_{GS} = 0V$			1.5	V
Maximum Body-Diode Continuous Current	I_S				8	A
Maximum Body-Diode Pulse Current	I_{SM}				32	A
DYNAMIC PARAMETERS						
Input Capacitance	C_{ISS}	$V_{GS} = 0V, V_{DS} = 25V,$ $f = 1MHz$		1431		pF
Output Capacitance	C_{OSS}			109		pF
Reverse Transfer Capacitance	C_{RSS}			9.5		pF
SWITCHING PARAMETERS						
Turn-On Delay Time	$t_{d(on)}$	$V_{DD} = 300V, V_{GS} = 10V,$ $R_G = 9.1\Omega,$ $I_D = 8A$	-	13.6		ns
Turn-Off Delay Time	$t_{d(off)}$		-	41.0		ns
Turn-On Rise Time	t_r			14.0		ns
Turn-Off Fall Time	t_f			23.6		ns
Total Gate Charge	Q_g	$V_{DS} = 300V$ $I_D = 8A$		28.4		nC
Gate Source Charge	Q_{gs}			7.3		nC
Gate Drain Charge	Q_{gd}			11.2		nC
Body Diode Reverse Recovery Time	t_{rr}	$I_F = 8A, di/dt = 100A/\mu s, V_{GS} = 0V$ $V_{DD} = 60V$		538	807	ns
Body Diode Reverse Recovery Charge	Q_{rr}			3181	4772	nC

Typical Characteristics

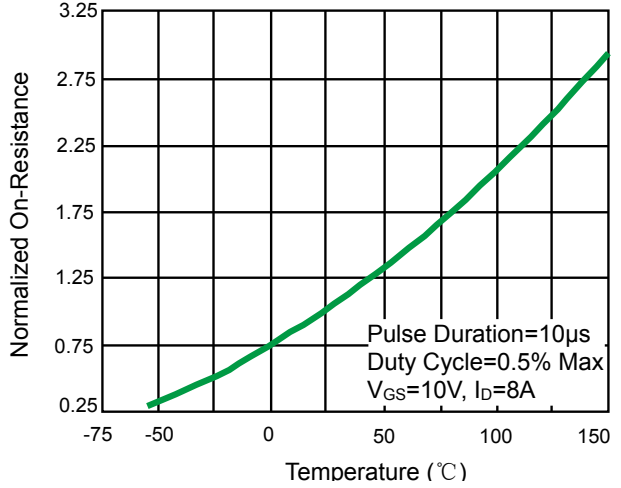
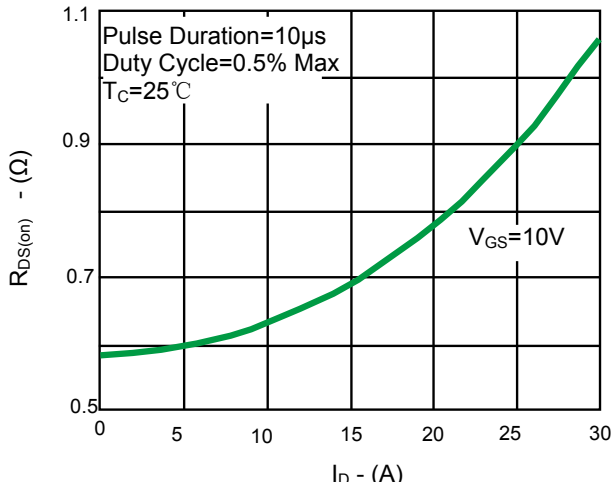
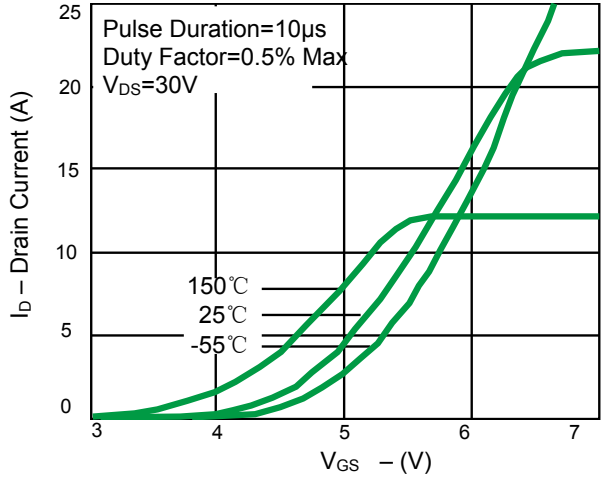
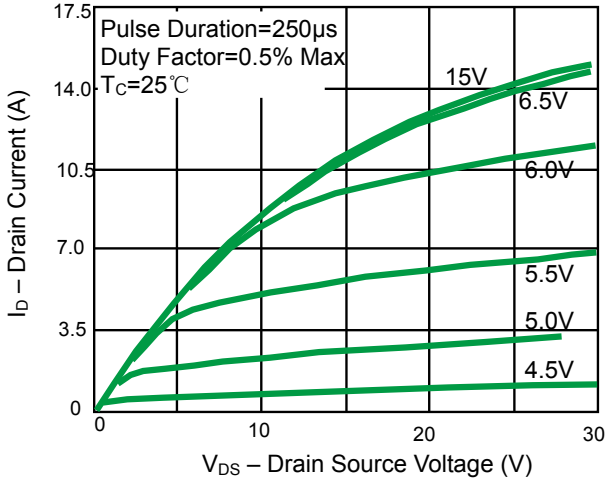

Product dimension(PNMTO600V8)(TO-220)

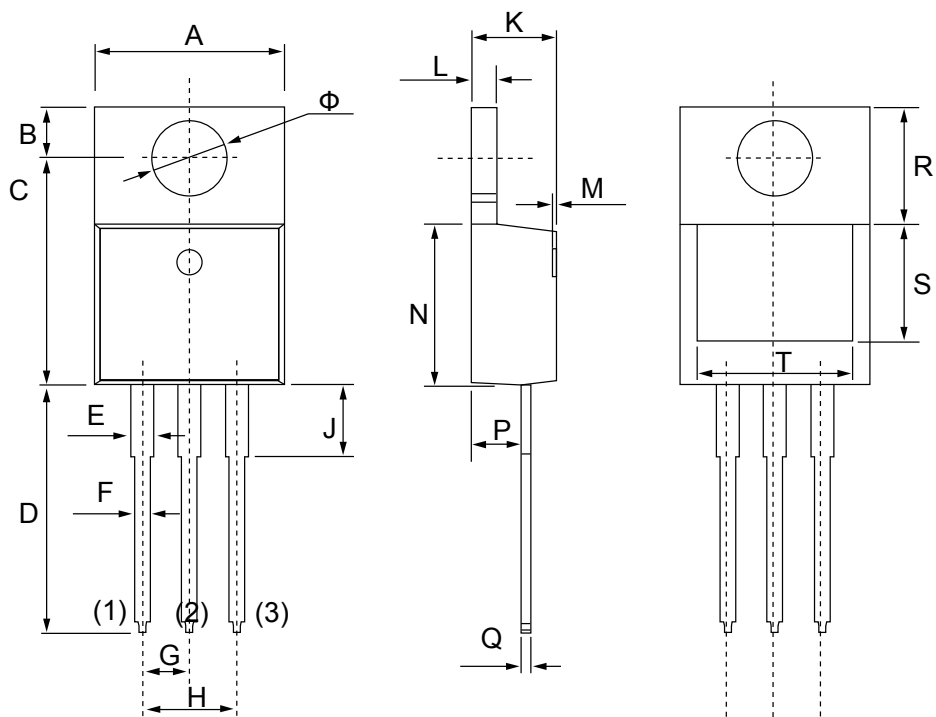

Dim	Millimeters		Inches	
	MIN	MAX	MIN	MAX
A	10.010	10.350	0.394	0.407
B	2.590	2.890	0.102	0.114
C	12.060	12.460	0.475	0.491
D	13.400	13.800	0.528	0.543
E	1.170	1.370	0.046	0.054
F	0.710	0.910	0.028	0.036
G	2.540 TYP.		0.100 TYP.	
H	4.980	5.180	0.196	0.204
J	3.560	3.960	0.140	0.156
K	4.470	4.670	0.176	0.184
L	1.200	1.400	0.047	0.055
M	0.000	0.300	0.000	0.012
N	8.500	8.900	0.335	0.350
P	2.520	2.820	0.099	0.111
Q	0.380	0.520	0.014	0.020
R	6.600 REF.		0.260 REF.	
S	6.060 REF.		0.239 REF.	
T	8.440 REF.		0.332 REF.	
Φ	3.735	3.935	0.147	0.155

Product dimension (PNMTOF600V8)(TO-220F)

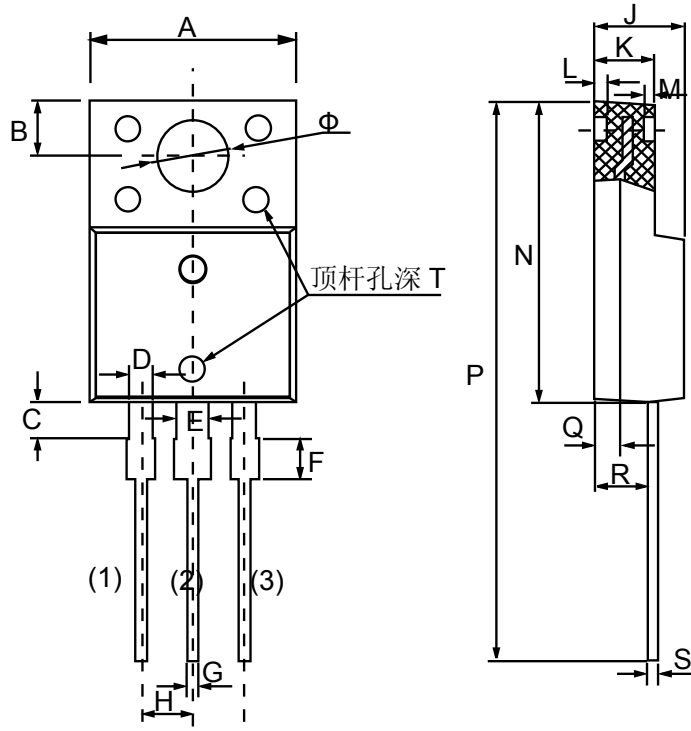

Dim	Millimeters		Inches	
	MIN	MAX	MIN	MAX
A	9.960	10.360	0.392	0.408
B	2.700 REF		0.106 REF	
C	1.700	1.900	0.067	0.075
D	1.100	1.350	0.043	0.053
E	1.500	1.750	0.059	0.069
F	1.900	2.100	0.075	0.083
G	0.500	0.750	0.020	0.030
H	2.540 TYP		0.100 TYP	
J	4.300	4.700	0.169	0.185
K	2.800	3.200	0.110	0.126
L	0.800 REF		0.031 REF	
M	0.500 REF		0.020 REF	
N	14.800	15.200	0.583	0.598
P	28.000	28.400	1.102	1.118
Q	1.300 REF		0.051 REF	
R	2.500	2.900	0.098	0.114
S	0.500	0.750	0.020	0.030
T	0.000	0.300	0.000	0.012
Φ	3.500 REF		0.138 REF	

IMPORTANT NOTICE

 and **Prisemi**[®] are registered trademarks of **Prisemi Electronics Co., Ltd (Prisemi)** ,Prisemi reserves the right to make changes without further notice to any products herein. Prisemi makes no warranty, representation or guarantee regarding the suitability of its products for any particular purpose, nor does Prisemi assume any liability arising out of the application or use of any product or circuit, and specifically disclaims any and all liability, including without limitation special, consequential or incidental damages. “Typical” parameters which may be provided in Prisemi data sheets and/or specifications can and do vary in different applications and actual performance may vary over time. All operating parameters, including “Typicals” must be validated for each customer application by customer’s technical experts. Prisemi does not convey any license under its patent rights nor the rights of others. The products listed in this document are designed to be used with ordinary electronic equipment or devices, Should you intend to use these products with equipment or devices which require an extremely high level of reliability and the malfunction of with would directly endanger human life (such as medical instruments, aerospace machinery, nuclear-reactor controllers, fuel controllers and other safety devices), please be sure to consult with our sales representative in advance.

Website: <http://www.prisemi.com>

For additional information, please contact your local Sales Representative.

©Copyright 2009, Prisemi Electronics

 **Prisemi**[®] is a registered trademark of Prisemi Electronics.

All rights are reserved.