



Power MOSFET

Features

- Robust High Voltage Termination
- Avalanche Energy Specified
- Source-to-Drain Diode Recovery Time Comparable to a Discrete Fast Recovery
- Diode is Characterized for Use in Bridge Circuits
- I_{BSS} and $V_{DS(on)}$ Specified at Elevated Temperature

General Description

This high voltage MOSFET uses an advanced termination scheme to provide enhanced voltage-blocking capability without degrading performance over time. In addition, this advanced MOSFET is designed to withstand high energy in avalanche and commutation modes. The new energy efficient design also offers a drain-to-source diode with a fast recovery time. Designed for high voltage, high speed switching applications in power supplies, converters and PWM motor controls, these devices are particularly well suited for bridge circuits where diode speed and commutating safe operating areas are critical and offer additional and safety margin against unexpected voltage transients.

Pin Configuration

TO-220/I TO-220
Front View

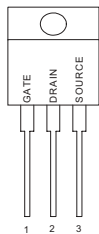

TO-252
Front View

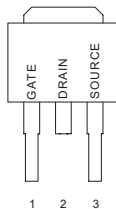

Symbol

TO-251
Front View

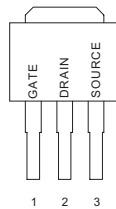

N-Channel MOSFET

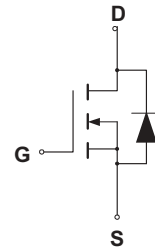

Absolute Maximum Ratings

Rating	Symbol	Value	Unit
Drain Current – Continuous	I_D	2.0	A
	I_{DM}	9.0	
Gate-to-Source Voltage – Continuous	V_{GS}	± 20	V
	V_{GSM}	± 40	V
Total Power Dissipation	P_D	60	W
		60	
		32	
Operating and Storage Temperature Range	T_J, T_{STG}	-55 to 150	$^{\circ}\text{C}$
Single Pulse Drain-to-Source Avalanche Energy – $T_J = 25^{\circ}\text{C}$ ($V_{DD} = 100\text{V}, V_{GS} = 10\text{V}, I_L = 2\text{A}, L = 10\text{mH}, R_G = 25\Omega$)	E_{AS}	20	mJ
Thermal Resistance – Junction to Case	θ_{JC}	1.0	$^{\circ}\text{C}/\text{W}$
	θ_{JA}	62.5	
Maximum Lead Temperature for Soldering Purposes, 1/8" from case for 10 seconds	T_L	260	$^{\circ}\text{C}$



Ordering Information

Part Number	Package
CTM02N60N251	TO-251
CTM02N60N252	TO-252
CTM02N60N220	TO-220
CTM02N60N220FP	ITO-220

Electrical Characteristics

Unless otherwise specified, $T_J = 25^\circ\text{C}$.

Characteristic	Symbol	CTM02N60			Units	
		Min	Typ	Max		
Drain-Source Breakdown Voltage ($V_{GS} = 0\text{ V}$, $I_D = 250\ \mu\text{A}$)	$V_{(BR)DSS}$	600			V	
Drain-Source Leakage Current ($V_{DS} = 600\text{ V}$, $V_{GS} = 0\text{ V}$) ($V_{DS} = 480\text{ V}$, $V_{GS} = 0\text{ V}$, $T_J = 125^\circ\text{C}$)	I_{DSS}			0.1 1.0	mA	
Gate-Source Leakage Current-Forward ($V_{GS} = 20\text{ V}$, $V_{DS} = 0\text{ V}$)	I_{GSSF}			100	nA	
Gate-Source Leakage Current-Reverse ($V_{GS} = -20\text{ V}$, $V_{DS} = 0\text{ V}$)	I_{GSSR}			-100	nA	
Gate Threshold Voltage ($V_{DS} = V_{GS}$, $I_D = 250\ \mu\text{A}$)	$V_{GS(th)}$	2.0		4.0	V	
Static Drain-Source On-Resistance ($V_{GS} = 10\text{ V}$, $I_D = 1.2\text{ A}$) *	$R_{DS(on)}$			4.4	Ω	
Forward Transconductance ($V_{DS} \geq 50\text{ V}$, $I_D = 1.0\text{ A}$) *	g_{FS}	1.4			S	
Input Capacitance	$(V_{DS} = 25\text{ V}$, $V_{GS} = 0\text{ V}$, $f = 1.0\text{ MHz}$)	C_{iss}		435	pF	
Output Capacitance		C_{oss}		56	pF	
Reverse Transfer Capacitance		C_{rss}		9.2	pF	
Turn-On Delay Time	$(V_{DD} = 300\text{ V}$, $I_D = 2.0\text{ A}$, $V_{GS} = 10\text{ V}$, $R_G = 18\ \Omega$) *	$t_{d(on)}$		12	ns	
Rise Time		t_r		21	ns	
Turn-Off Delay Time		$t_{d(off)}$		30	ns	
Fall Time		t_f		24	ns	
Total Gate Charge	$(V_{DS} = 400\text{ V}$, $I_D = 2.0\text{ A}$, $V_{GS} = 10\text{ V}$) *	Q_g		13	nC	
Gate-Source Charge		Q_{gs}		2.0	nC	
Gate-Drain Charge		Q_{gd}		6.0	nC	
Internal Drain Inductance (Measured from the drain lead 0.25" from package to center of die)	L_D			4.5	nH	
Internal Drain Inductance (Measured from the source lead 0.25" from package to source bond pad)	L_S			7.5	nH	
SOURCE-DRAIN DIODE CHARACTERISTICS						
Forward On-Voltage(1)	$(I_S = 2.0\text{ A}$, $V_{GS} = 0\text{ V}$, $d_S/d_t = 100\text{ A}/\mu\text{s}$)	V_{SD}			1.5	V
Forward Turn-On Time		t_{on}		**		ns
Reverse Recovery Time		t_{rr}			340	ns

* Pulse Test: Pulse Width $\leq 300\ \mu\text{s}$, Duty Cycle $\leq 2\%$

** Negligible, Dominated by circuit inductance



Typical Electrical Characteristics

Figure 1. On-Region Characteristics

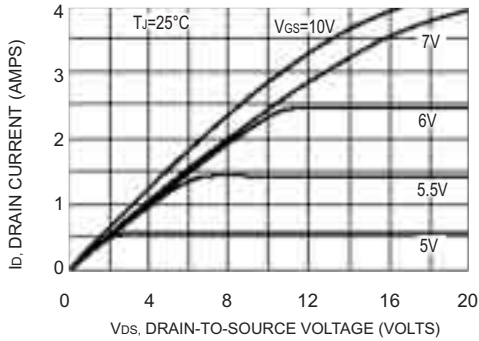

Figure 2. Transfer Characteristics

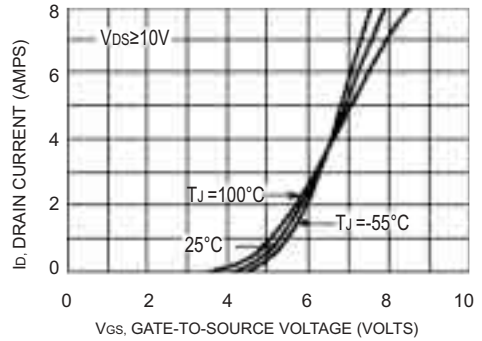

Figure 3. On-Resistance versus Drain Current and Temperature

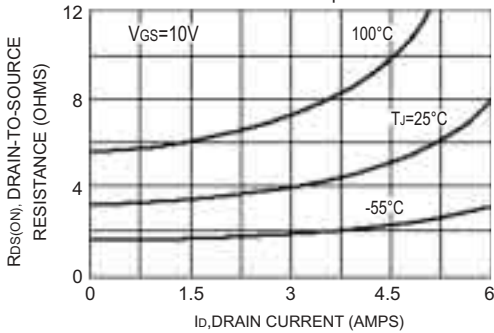

Figure 4. On-Resistance versus Drain Current and Gate Voltage

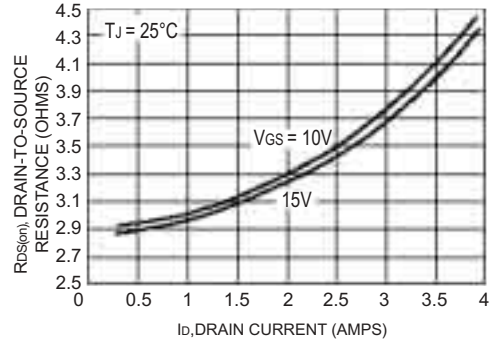

Figure 5. On-Resistance Variation with Temperature

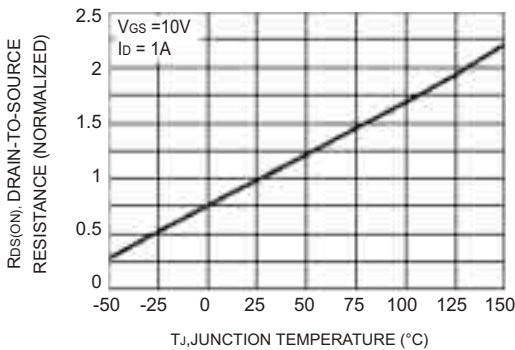
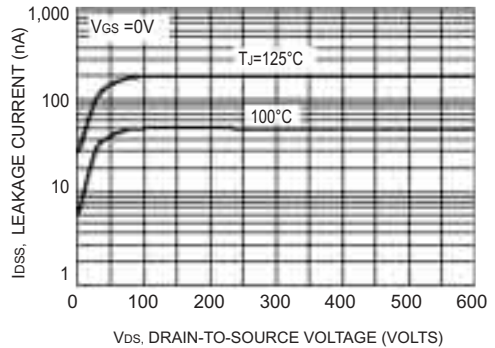

Figure 6. Drain-To-Source Leakage Current versus Voltage





Package Dimension

TO-220

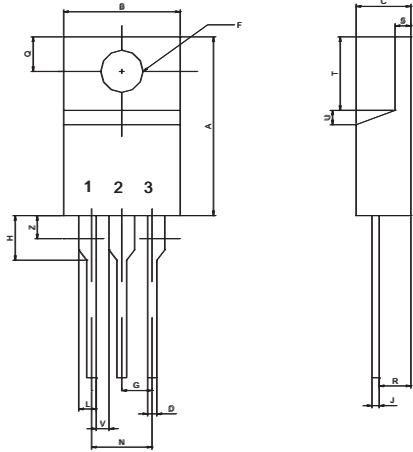

PIN 1: GATE
 PIN 2: DRAIN
 PIN 3: SOURCE

SYMBOLS	DIMENSIONS IN MILLIMETERS			DIMENSIONS IN INCHS		
	MIN	NOM	MAX	MIN	NOM	MAX
A	14.48	----	15.75	0.570	----	0.620
B	9.66	----	10.28	0.380	----	0.405
C	4.07	----	4.82	0.160	----	0.190
D	0.64	----	0.88	0.025	----	0.035
F	3.61	----	3.73	0.142	----	0.147
G	2.42	----	2.66	0.095	----	0.105
H	2.80	----	3.93	0.110	----	0.155
J	0.46	----	0.64	0.018	----	0.025
K	12.70	----	14.27	0.500	----	0.562
L	1.15	----	1.52	0.045	----	0.060
N	4.83	----	5.33	0.190	----	0.210
Q	2.54	----	3.04	0.100	----	0.120
R	2.04	----	2.79	0.080	----	0.110
S	1.15	----	1.39	0.045	----	0.055
T	5.97	----	6.47	0.235	----	0.255
U	0.00	----	1.27	0.000	----	0.050
V	1.15	----	----	0.045	----	----
Z	----	----	2.04	----	----	0.080

ITO-220

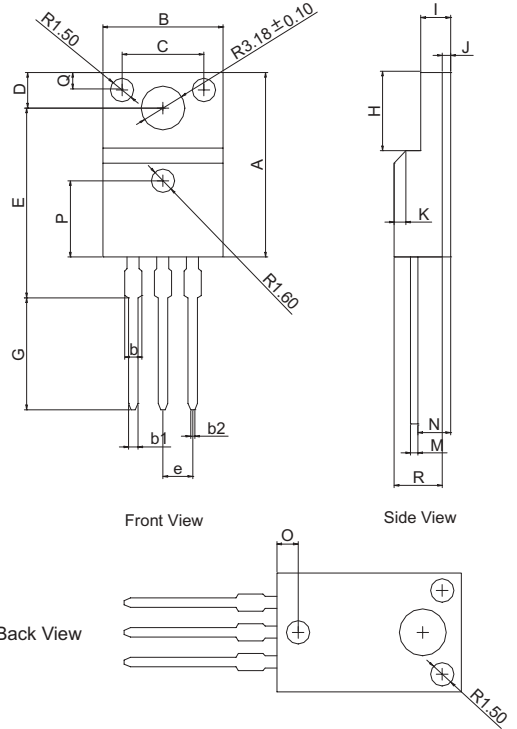

Back View

SYMBOLS	DIMENSIONS IN MILLIMETERS			DIMENSIONS IN INCHS		
	MIN	NOM	MAX	MIN	NOM	MAX
A	15.67	----	16.07	0.617	----	0.633
B	9.96	----	10.36	0.392	----	0.408
C	----	7.00	----	----	0.275	----
D	3.20	----	3.40	0.126	----	0.134
E	15.60	----	16.00	0.614	----	0.630
G	9.45	----	10.05	0.372	----	0.396
H	6.48	----	6.88	0.255	----	0.279
I	2.34	----	2.74	0.092	----	0.108
J	----	0.70	----	----	0.028	----
K	----	1.00	----	----	0.039	----
M	0.45	----	0.60	0.018	----	0.024
N	2.56	----	2.96	0.101	----	0.117
O	----	1.80	----	----	0.071	----
P	----	6.50	----	----	0.256	----
Q	----	1.50	----	----	0.059	----
R	4.50	----	4.90	0.028	----	0.035
b	----	----	1.47	----	----	0.058
b1	0.70	----	0.90	0.028	----	0.035
b2	0.25	----	0.45	0.010	----	0.018
e	----	2.54	----	----	0.100	----



Package Dimension

TO-252

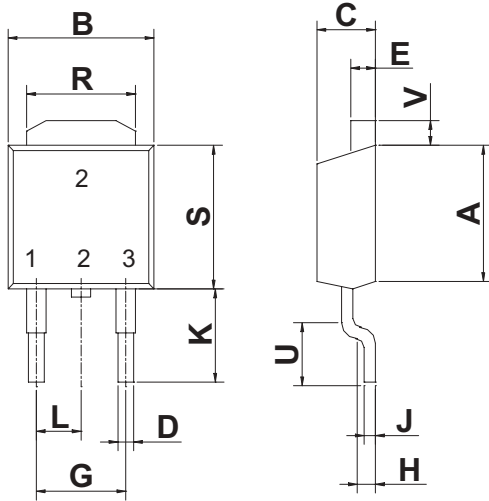

PIN 1: GATE
 PIN 2: DRAIN
 PIN 3: SOURCE

SYMBOLS	DIMENSIONS IN MILLIMETERS			DIMENSIONS IN INCHS		
	MIN	NOM	MAX	MIN	NOM	MAX
A	14.48	----	15.75	0.570	----	0.620
B	9.66	----	10.28	0.380	----	0.405
C	4.07	----	4.82	0.160	----	0.190
D	0.64	----	0.88	0.025	----	0.035
F	3.61	----	3.73	0.142	----	0.147
G	2.42	----	2.66	0.095	----	0.105
H	2.80	----	3.93	0.110	----	0.155
J	0.46	----	0.64	0.018	----	0.025
K	12.70	----	14.27	0.500	----	0.562
L	1.15	----	1.52	0.045	----	0.060
N	4.83	----	5.33	0.190	----	0.210
Q	2.54	----	3.04	0.100	----	0.120
R	2.04	----	2.79	0.080	----	0.110
S	1.15	----	1.39	0.045	----	0.055
T	5.97	----	6.47	0.235	----	0.255
U	0.00	----	1.27	0.000	----	0.050
V	1.15	----	----	0.045	----	----
Z	----	----	2.04	----	----	0.080

TO-251

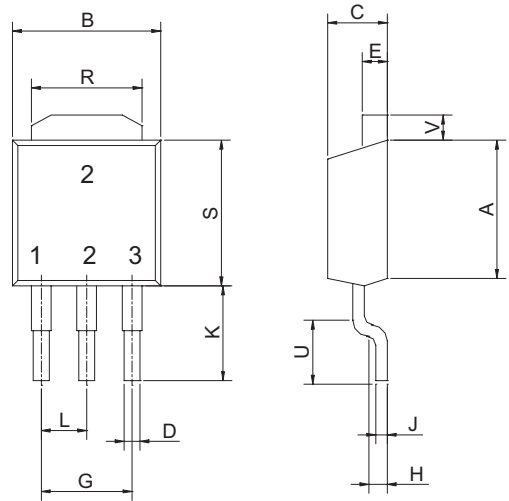

PIN 1: GATE
 PIN 2: DRAIN
 PIN 3: SOURCE

SYMBOLS	DIMENSIONS IN MILLIMETERS			DIMENSIONS IN INCHS		
	MIN	NOM	MAX	MIN	NOM	MAX
A	15.67	----	16.07	0.617	----	0.633
B	9.96	----	10.36	0.392	----	0.408
C	----	7.00	----	----	0.275	----
D	3.20	----	3.40	0.126	----	0.134
E	15.60	----	16.00	0.614	----	0.630
G	9.45	----	10.05	0.372	----	0.396
H	6.48	----	6.88	0.255	----	0.279
I	2.34	----	2.74	0.092	----	0.108
J	----	0.70	----	----	0.028	----
K	----	1.00	----	----	0.039	----
M	0.45	----	0.60	0.018	----	0.024
N	2.56	----	2.96	0.101	----	0.117
O	----	1.80	----	----	0.071	----
P	----	6.50	----	----	0.256	----
Q	----	1.50	----	----	0.059	----
R	4.50	----	4.90	0.028	----	0.035
b	----	----	1.47	----	----	0.058
b1	0.70	----	0.90	0.028	----	0.035
b2	0.25	----	0.45	0.100	----	0.018
e	----	2.54	----	----	0.100	----