

240 Amp Schottky Rectifier

HS24035 – HS24045

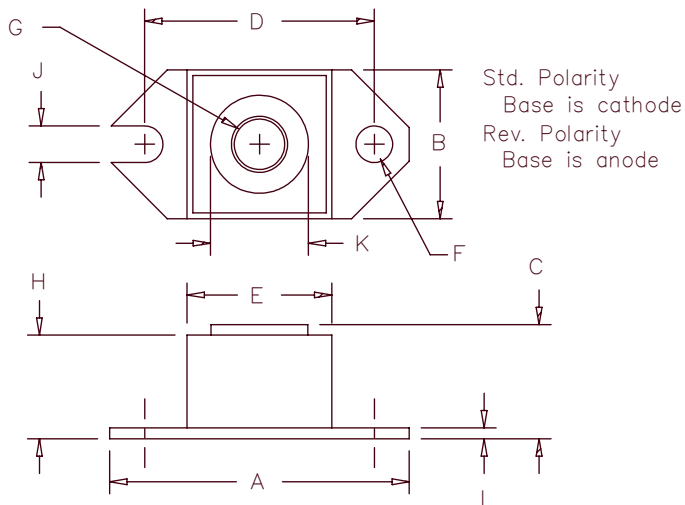

Dim.	Inches		Millimeter		Notes
	Minimum	Maximum	Minimum	Maximum	
A	1.52	1.56	38.61	39.62	
B	.725	.775	18.42	19.69	
C	.605	.625	15.37	15.88	
D	1.182	1.192	30.02	30.28	
E	.745	.755	18.92	19.18	Sq.
F	.152	.160	3.86	4.06	Dia.
G			1/4-20 UNC-2B		
H	.525	.580	13.34	14.73	
J	.156	.160	3.96	4.06	
K	.495	.505	12.57	12.83	Dia.
L	.120	.130	3.05	3.30	

Microsemi Catalog Number	Industry Part Number	Working Peak Reverse Voltage	Repetitive Peak Reverse Voltage
HS24035*	240NQ035, 244NQ035 MBRP20035L, MBRP30035L MBR24035	35V	35V
HS24040*	240NQ040, 244NQ040 MBR24040	40V	40V
HS24045*	240NQ045, 244NQ045 MBR24045	45V	45V

*Add suffix R for Reverse Polarity

- Schottky Barrier Rectifier
- Guard ring protection
- Low forward voltage
- V_{RRM} – 35 to 45 volts
- 150°C junction temperature
- Reverse energy tested
- ROHS Compliant

Electrical Characteristics

Average forward current	I_{AV} 240 Amps	$T_C = 92^\circ\text{C}$, square wave, $R_{\theta JC} = 0.24^\circ\text{C/W}$
Maximum surge current	I_{FSM} 3500 Amp	8.3 ms, half sine $T_J = 150^\circ\text{C}$
Max repetitive peak reverse current	$R(0V)$ 2 Amps	$f = 1 \text{ KHz}$, 25°C , $1\mu\text{sec}$ square wave
Max peak forward voltage	V_{FM} 0.49 Volts	$I_{FM} = 240\text{A}$; $T_J = 125^\circ\text{C}^*$
Max peak forward voltage	V_{FM} 0.55 Volts	$I_{FM} = 240\text{A}$; $T_J = 25^\circ\text{C}^*$
Max peak reverse current	R_M 3.0 A	V_{RRM} , $T_J = 125^\circ\text{C}^*$
Max peak reverse current	R_M 12 mA	V_{RRM} , $T_J = 25^\circ\text{C}$
Typical junction capacitance	C_j 10500 pF	$V_R = 5.0\text{V}$, $T_J = 25^\circ\text{C}$

*Pulse test: Pulse width 300 μsec , Duty cycle 2%

Thermal and Mechanical Characteristics

Storage temp range	T_{STG}	-55°C to 175°C
Operating junction temp range	T_J	-55°C to 150°C
Maximum thermal resistance	$R_{\theta JC}$	0.24°C/W Junction to case
Typical thermal resistance (greased)	$R_{\theta CS}$	0.12°C/W Case to sink
Terminal torque		35-40 inch pounds
Mounting torque		20-25 inch pounds
Weight		1.1 ounces (28 grams)

HS24035 – HS24045

Figure 1
Typical Forward Characteristics

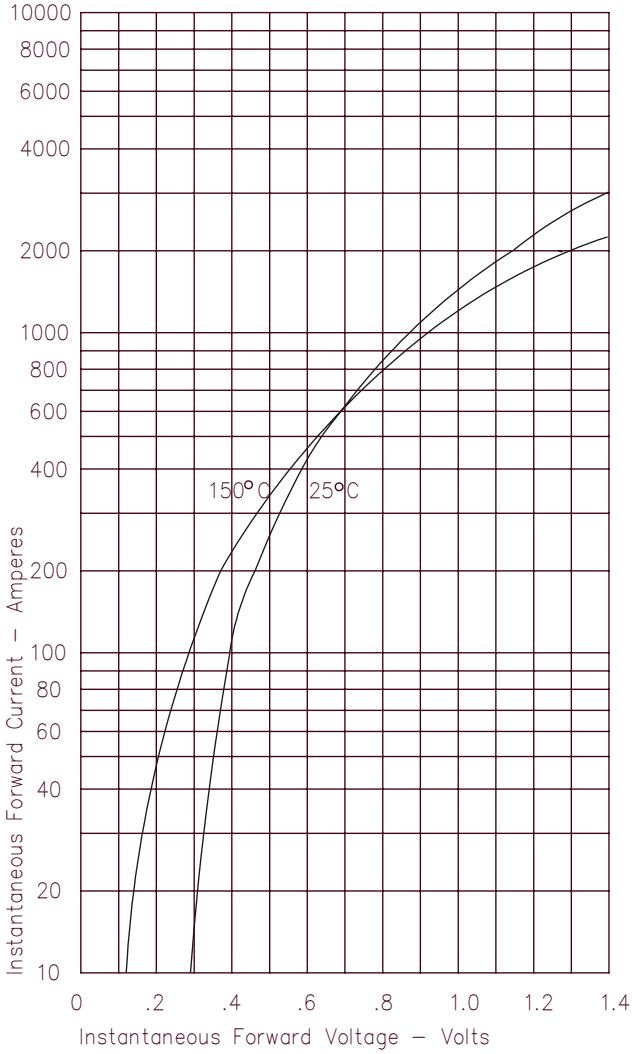

Figure 3
Typical Junction Capacitance

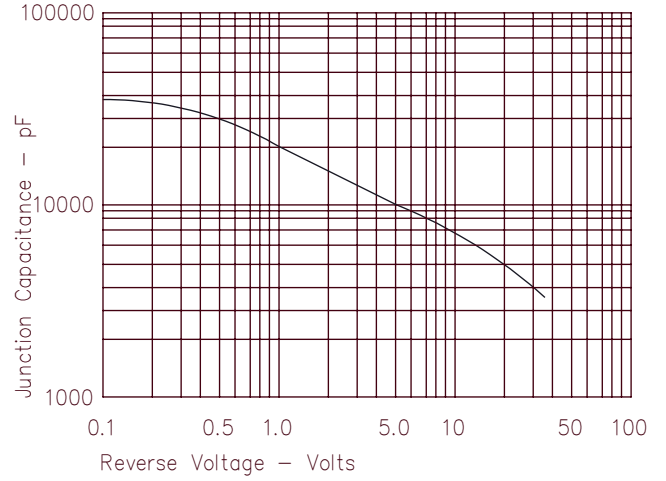

Figure 4
Forward Current Derating

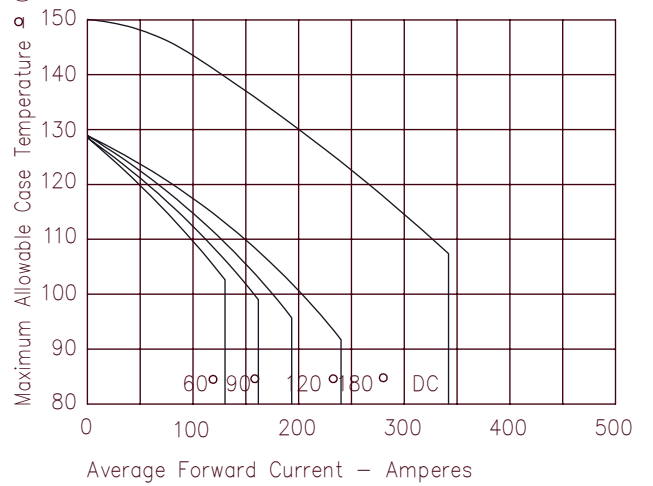

Figure 2
Typical Reverse Characteristics

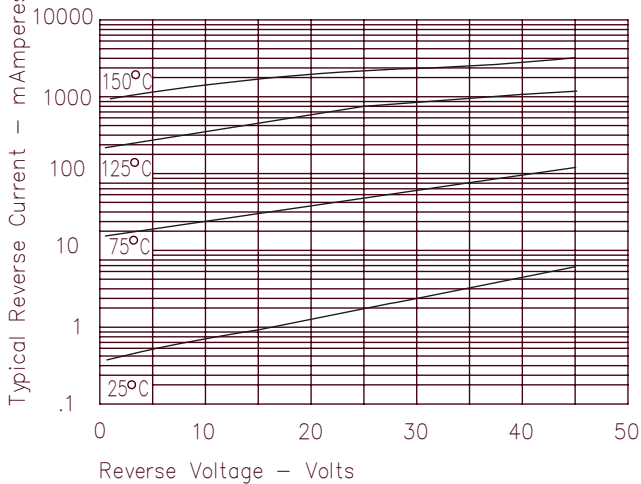
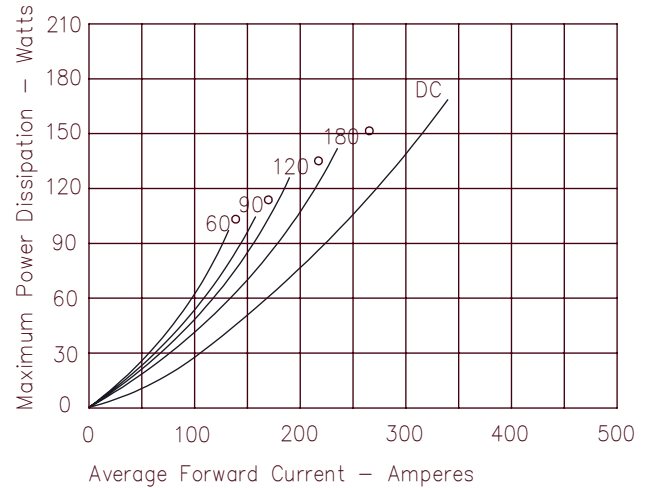

Figure 5
Maximum Forward Power Dissipation



This datasheet has been downloaded from:

www.EEworld.com.cn

Free Download

Daily Updated Database

100% Free Datasheet Search Site

100% Free IC Replacement Search Site

Convenient Electronic Dictionary

Fast Search System

www.EEworld.com.cn

This datasheet has been downloaded from:

www.EEworld.com.cn

Free Download

Daily Updated Database

100% Free Datasheet Search Site

100% Free IC Replacement Search Site

Convenient Electronic Dictionary

Fast Search System

www.EEworld.com.cn