

MOS POWER 4

T.39-15

SML4020BN	400V	26.0A	0.20Ω
SML3520BN	350V	26.0A	0.20Ω
SML4025BN	400V	23.0A	0.25Ω
SML3525BN	350V	23.0A	0.20Ω

N - CHANNEL ENHANCEMENT MODE HIGH VOLTAGE POWER MOSFETS

MAXIMUM RATINGS

All Ratings: $T_C = 25^\circ\text{C}$ unless otherwise specified.

Symbol	Parameter	SML				UNIT
		3520BN	4020BN	3525BN	4025BN	
V_{DSS}	Drain-Source Voltage	350	400	350	400	Volts
I_D	Continuous Drain Current	26		23		Amps
I_{DM}	Pulsed Drain Current ¹	104		92		Amps
V_{GS}	Gate-Source Voltage	±30				Volts
P_D	Total Power Dissipation @ $T_C = 25^\circ\text{C}$, Derate Above 25°C	310				Watts
T_J, T_{STG}	Operating and Storage Junction Temperature Range	- 55 to 150				$^\circ\text{C}$

STATIC ELECTRICAL CHARACTERISTICS

Symbol	Characteristic / Test Conditions / Part Number	MIN	TYP	MAX	UNIT	
BV_{DSS}	Drain-Source Breakdown Voltage ($V_{GS} = 0V, I_D = 250 \mu\text{A}$)	SML4020BN / SML4025BN	400			Volts
		SML3520BN / SML3525BN	350			Volts
I_{DSS}	Zero Gate Voltage Drain Current ($V_{DS} = V_{DSS}, V_{GS} = 0V$) ($V_{DS} = 0.8 V_{DSS}, V_{GS} = 0V, T_C = 125^\circ\text{C}$)			250	μA	
				1000		
I_{GSS}	Gate-Source Leakage Current ($V_{GS} = \pm 30V, V_{DS} = 0V$)			±100	nA	
$I_{D(ON)}$	On State Drain Current ² ($V_{DS} > I_{D(ON)} \times R_{DS(ON)} \text{ Max}, V_{GS} = 10V$)	SML4020BN / SML3520BN	26			Amps
		SML4025BN / SML3525BN	23			Amps
$V_{GS(TH)}$	Gate Threshold Voltage ($V_{DS} = V_{GS}, I_D = 1\text{mA}$)	2		4	Volts	
$R_{DS(ON)}$	Static Drain-Source On-State Resistance ² ($V_{GS} = 10V, I_D = 0.5 I_D [\text{Cont.}]$)	SML4020BN / SML3520BN			0.20	Ohms
		SML4025BN / SML3525BN			0.25	Ohms

THERMAL CHARACTERISTICS

Symbol	Characteristic	MIN	TYP	MAX	UNIT
$R_{\theta JC}$	Junction to Case			0.40	$^\circ\text{C/W}$
$R_{\theta JA}$	Junction to Ambient			40	$^\circ\text{C/W}$
T_L	Max. Lead Temp. for Soldering Conditions: 0.063" from Case for 10 Sec.			300	$^\circ\text{C}$

SEMELAB PLC
Coventry Road,
Lutterworth,
Leicestershire.
LE17 4JB.

Telephone: (0455) 556565
Telex: 341927
Facsimile: (0455) 552612

DYNAMIC CHARACTERISTICS

SML4020/3520/4025/3525BN

Symbol	Characteristic	Test Conditions	MIN	TYP	MAX	UNIT
C_{iss}	Input Capacitance	$V_{GS} = 0V$ $V_{DS} = 25V$ $f = 1\text{ MHz}$		2380	2950	pF
C_{oss}	Output Capacitance			563	750	pF
C_{rss}	Reverse Transfer Capacitance			207	310	pF
Q_g	Total Gate Charge ³	$V_{GS} = 10V, I_D = I_D[\text{Cont.}]$ $V_{DD} = 0.5 V_{DSS}$		94	130	nC
Q_{gs}	Gate-Source Charge			11	16	nC
Q_{gd}	Gate-Drain ("Miller") Charge			47	70	nC
$t_d(\text{on})$	Turn-on Delay Time	$V_{DD} = 0.5 V_{DSS}$ $I_D = I_D[\text{Cont.}], V_{GS} = 15V$ $R_G = 1.8\Omega$		14	28	ns
t_r	Rise Time			29	57	ns
$t_d(\text{off})$	Turn-off Delay Time			60	90	ns
t_f	Fall Time			40	80	ns

SOURCE-DRAIN DIODE RATINGS AND CHARACTERISTICS

Symbol	Characteristic / Test Conditions / Part Number	MIN	TYP	MAX	UNIT	
I_S	Continuous Source Current (Body Diode)	SML4020BN / SML3520BN			26	Amps
		SML4025BN / SML3525BN			23	Amps
I_{SM}	Pulsed Source Current ¹ (Body Diode)	SML4020BN / SML3520BN			104	Amps
		SML4025BN / SML3525BN			92	Amps
V_{SD}	Diode Forward Voltage ² ($V_{GS} = 0V, I_S = -I_D[\text{Cont.}]$)			1.3	Volts	
t_{rr}	Reverse Recovery Time ($I_S = -I_D[\text{Cont.}], dI_S/dt = 100A/\mu s$)	180	360	720	ns	
Q_{rr}	Reverse Recovery Charge	3	6	12	μC	

SAFE OPERATING AREA CHARACTERISTICS

Symbol	Characteristic	Test Conditions / Part Number	MIN	TYP	MAX	UNIT
SOA1	Safe Operating Area	$V_{DS} = 0.4 V_{DSS}, I_{DS} = P_D / 0.4 V_{DSS}, t = 1\text{ Sec.}$	310			Watts
SOA2	Safe Operating Area	$I_{DS} = I_D[\text{Cont.}], V_{DS} = P_D / I_D[\text{Cont.}], t = 1\text{ Sec.}$	310			Watts
I_{LM}	Inductive Current Clamped	SML4020BN / SML3520BN	104			Amps
		SML4025BN / SML3525BN	92			Amps

1.) Repetitive Rating: Pulse width limited by maximum junction temperature. See Transient Thermal Impedance Curve. (Fig.1)

2.) Pulse Test: Pulse width < 380 μs
Duty Cycle < 2%
3.) See MIL-STD-750 Method 3471

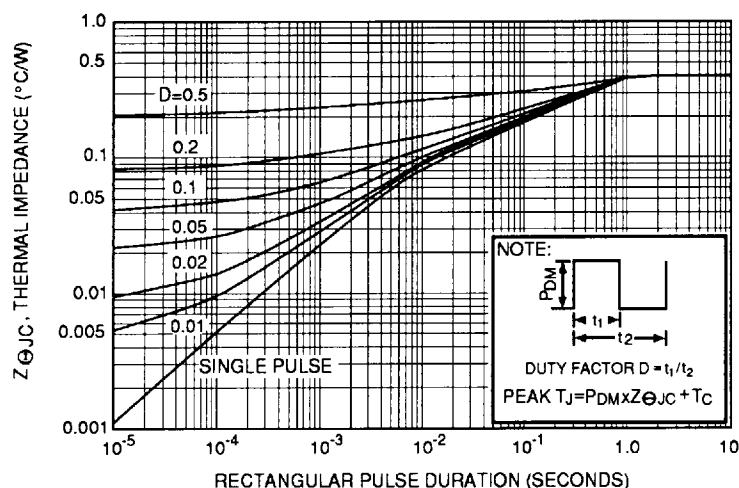
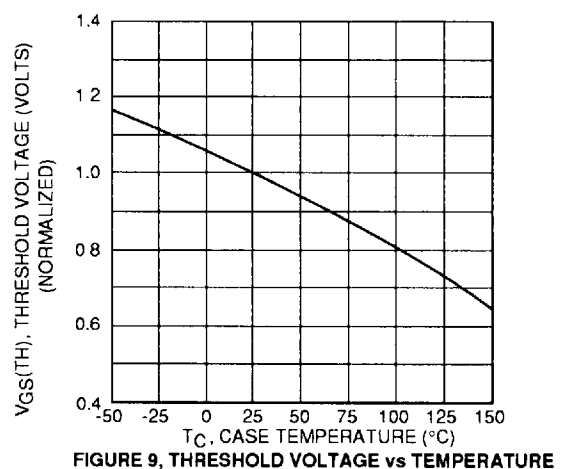
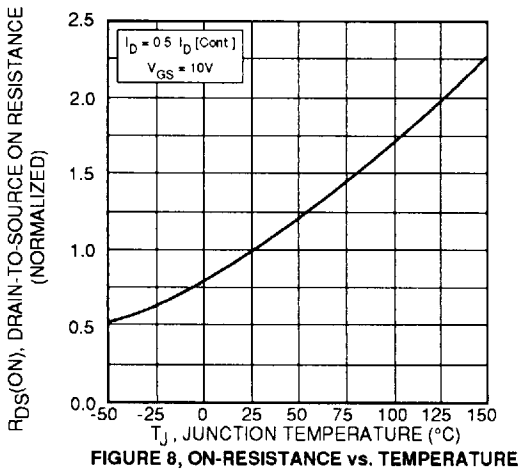
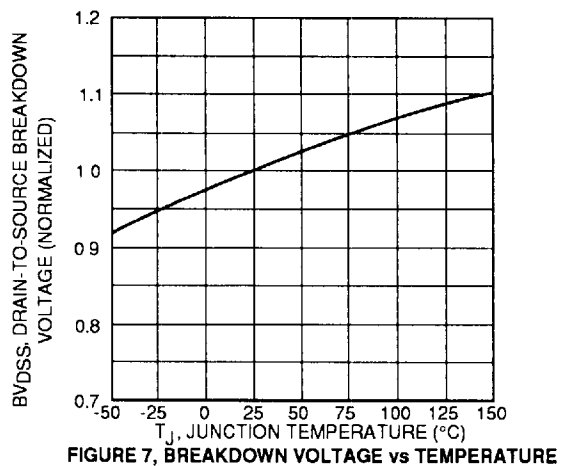
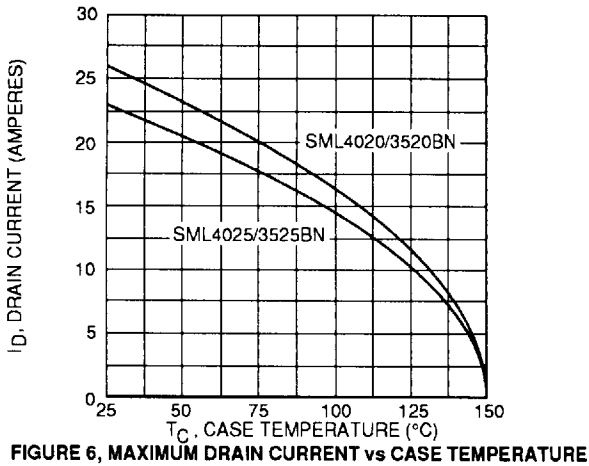
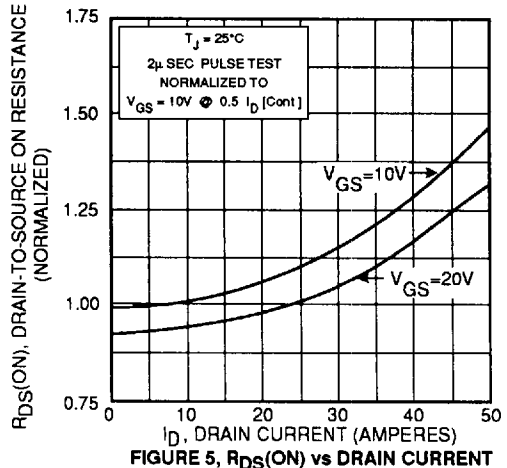
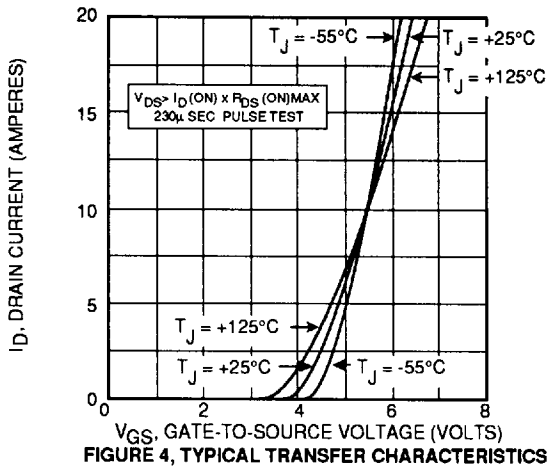
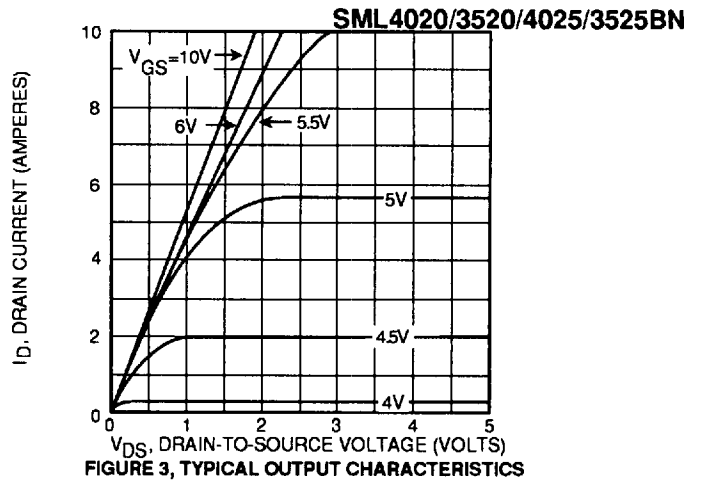
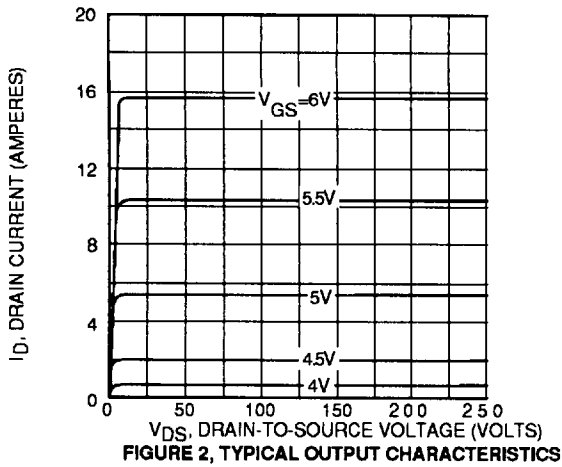

FIGURE 1, MAXIMUM EFFECTIVE TRANSIENT THERMAL IMPEDANCE, JUNCTION-TO-CASE vs PULSE DURATION



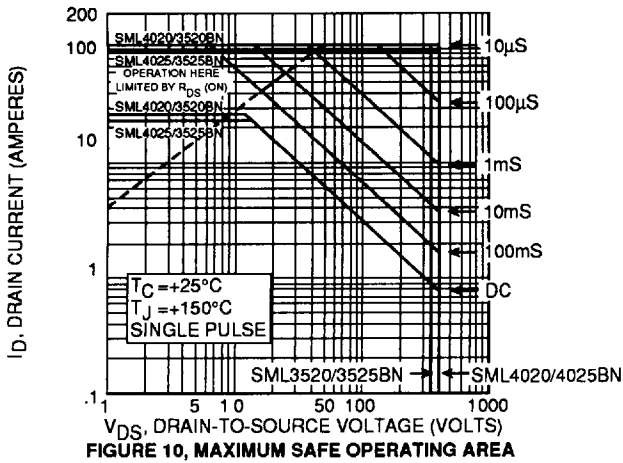

FIGURE 10, MAXIMUM SAFE OPERATING AREA

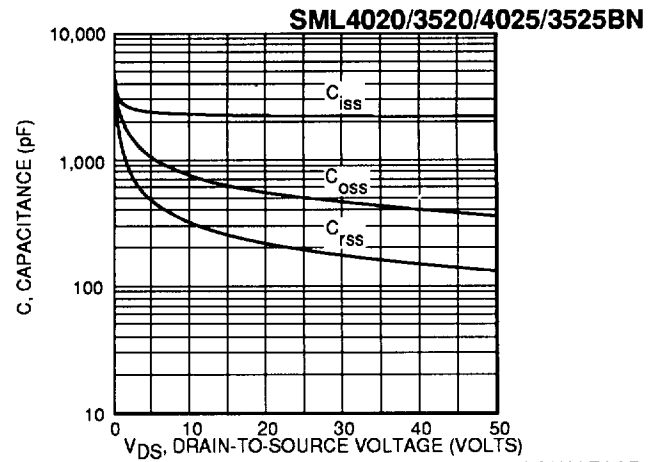

FIGURE 11, TYPICAL CAPACITANCE vs DRAIN-TO-SOURCE VOLTAGE

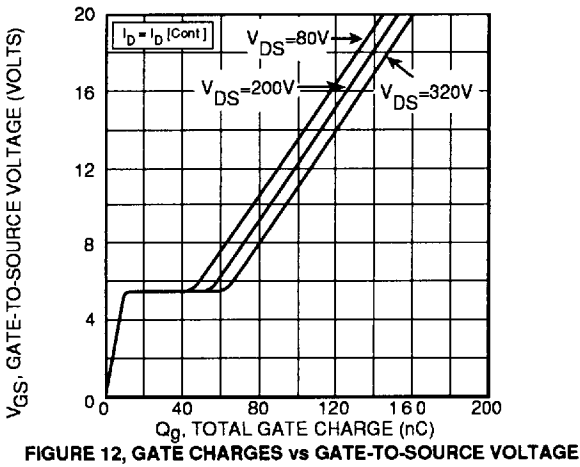

FIGURE 12, GATE CHARGES vs GATE-TO-SOURCE VOLTAGE

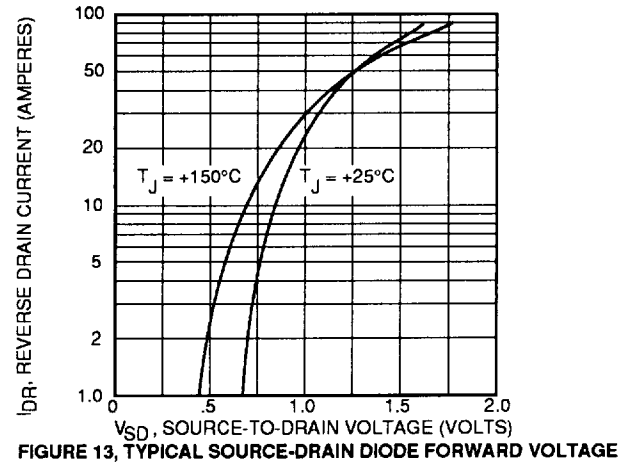
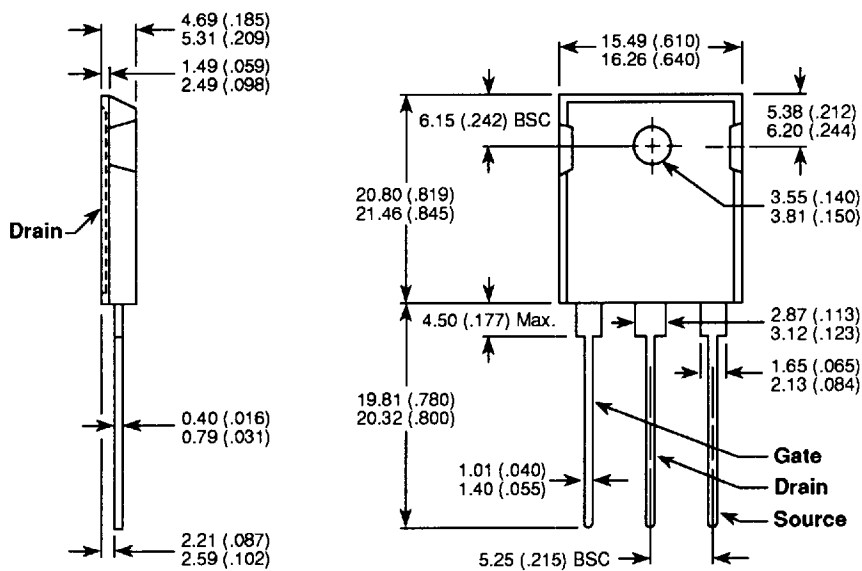

FIGURE 13, TYPICAL SOURCE-DRAIN DIODE FORWARD VOLTAGE

TO-247AD Package Outline



Dimensions in Millimeters and (Inches)