



STP60NS04ZB

N-CHANNEL CLAMPED 10mΩ - 60A TO-220 FULLY PROTECTED MESH OVERLAY™ MOSFET

TYPE	V _{DSS}	R _{DS(on)}	I _D
STP60NS04ZB	CLAMPED	< 0.015 Ω	60 A

- TYPICAL R_{DS(on)} = 0.010 Ω
- 100% AVALANCHE TESTED
- LOW CAPACITANCE AND GATE CHARGE
- 175°C MAXIMUM JUNCTION TEMPERATURE

DESCRIPTION

This fully clamped MOSFET is produced by using the latest advanced Company's Mesh Overlay process which is based on a novel strip layout. The inherent benefits of the new technology coupled with the extra clamping capabilities make this product particularly suitable for the harshest operation conditions such as those encountered in the automotive environment. Any other application requiring extra ruggedness is also recommended.

APPLICATIONS

- ABS, SOLENOID DRIVERS
- MOTOR CONTROL
- DC-DC CONVERTERS

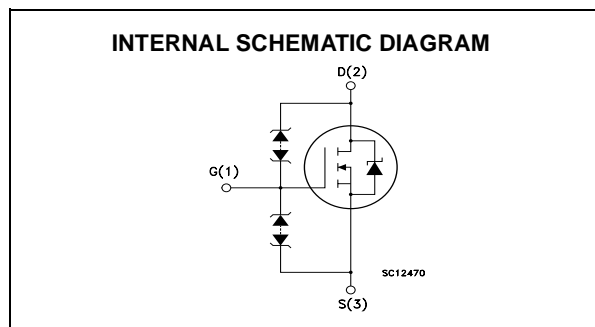
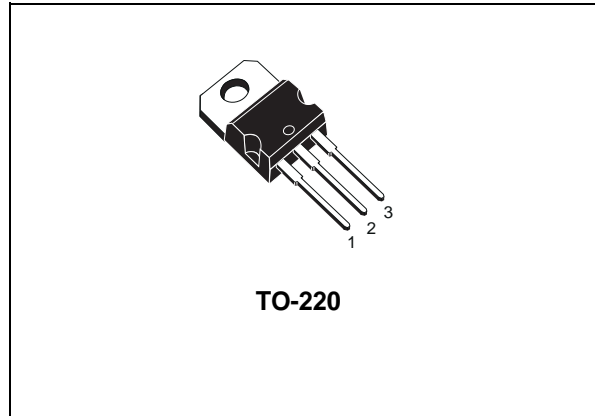

ABSOLUTE MAXIMUM RATINGS

Symbol	Parameter	Value	Unit
V _{DS}	Drain-source Voltage (V _{GS} = 0)	CLAMPED	V
V _{DG}	Drain-gate Voltage	CLAMPED	V
V _{GS}	Gate- source Voltage	CLAMPED	V
I _D	Drain Current (continuous) at T _C = 25°C	60	A
I _D	Drain Current (continuous) at T _C = 100°C	42	A
I _{DG}	Drain Gate Current (continuous)	± 50	mA
I _{GS}	Gate Source Current (continuous)	± 50	mA
I _{DM} (•)	Drain Current (pulsed)	240	A
P _{TOT}	Total Dissipation at T _C = 25°C	150	W
	Derating Factor	1	W/°C
V _{ESD(G-S)}	Gate-Source ESD(HBM-C=100 pF, R=1.5 KΩ)	6	kV
V _{ESD(G-D)}	Gate-Drain ESD(HBM-C=100 pF, R=1.5 KΩ)	4	kV
V _{ESD(D-S)}	Drain-Source ESD(HBM-C=100 pF, R=1.5 KΩ)	4	kV
T _{stg}	Storage Temperature	-65 to 175	°C
T _j	Max. Operating Junction Temperature		

(•)Pulse width limited by safe operating area

STP60NS04ZB

THERMAL DATA

Rthj-case	Thermal Resistance Junction-case Max	1.0	°C/W
Rthj-amb	Thermal Resistance Junction-ambient Max	62.5	°C/W
T _l	Maximum Lead Temperature For Soldering Purpose	300	°C

AVALANCHE CHARACTERISTICS

Symbol	Parameter	Max Value	Unit
I _{AR}	Avalanche Current, Repetitive or Not-Repetitive (pulse width limited by T _j max, δ < 1%)	60	A
E _{AS}	Single Pulse Avalanche Energy (starting T _j = 25 °C, I _D = I _{AR} , V _{DD} = 30 V)	400	mJ

ELECTRICAL CHARACTERISTICS (T_{CASE} = 25°C UNLESS OTHERWISE SPECIFIED)

OFF

Symbol	Parameter	Test Conditions	Min.	Typ.	Max.	Unit
V _{(BR)DSS}	Clamped Voltage	I _D = 1 mA, V _{GS} = 0 -40 < T _j < 175 °C	33			V
I _{DSS}	Zero Gate Voltage Drain Current (V _{GS} = 0)	V _{DS} = 16 V, T _j = 150 °C V _{DS} = 16 V, T _j = 175 °C			50 100	μA μA
I _{GSS}	Gate-body Leakage Current (V _{DS} = 0)	V _{GS} = ±10 V, T _j = 175 °C V _{GS} = ±16 V, T _j = 175 °C			50 150	μA μA
V _{GSS}	Gate-Source Breakdown Voltage	I _{GS} = ±100 μA	18			V

ON (1)

Symbol	Parameter	Test Conditions	Min.	Typ.	Max.	Unit
V _{GS(th)}	Gate Threshold Voltage	V _{DS} = V _{GS} , I _D = 1 mA -40 < T _j < 150 °C	1.7	3	4.2	V
R _{DS(on)}	Static Drain-source On Resistance	V _{GS} = 10 V, I _D = 30 A V _{GS} = 16 V, I _D = 30 A		11 10	15 14	mΩ mΩ

DYNAMIC

Symbol	Parameter	Test Conditions	Min.	Typ.	Max.	Unit
g _{fs} (1)	Forward Transconductance	V _{DS} = 15 V, I _D = 30 A	20	40		S
C _{iss}	Input Capacitance	V _{DS} = 25 V, f = 1 MHz, V _{GS} = 0		1700	2100	pF
C _{oss}	Output Capacitance			800	1000	pF
C _{rss}	Reverse Transfer Capacitance			190	240	pF

ELECTRICAL CHARACTERISTICS (CONTINUED)

SWITCHING ON

Symbol	Parameter	Test Conditions	Min.	Typ.	Max.	Unit
Q_g	Total Gate Charge	$V_{DD} = 18\text{ V}$, $I_D = 60\text{ A}$, $V_{GS} = 10\text{ V}$		48	62	nC
Q_{gs}	Gate-Source Charge			13		nC
Q_{gd}	Gate-Drain Charge			16		nC

SWITCHING OFF

Symbol	Parameter	Test Conditions	Min.	Typ.	Max.	Unit
$t_{r(Voff)}$	Off Voltage Rise Time	$V_{CLAMP} = 30\text{ V}$, $I_D = 60\text{ A}$,		60	75	ns
t_f	Fall Time	$R_G = 4.7\ \Omega$, $V_{GS} = 10\text{ V}$		45	60	ns
t_c	Cross-over Time	(see test circuit, Figure 3)		100	130	ns

SOURCE DRAIN DIODE

Symbol	Parameter	Test Conditions	Min.	Typ.	Max.	Unit
I_{SD}	Source-drain Current				60	A
$I_{SDM(2)}$	Source-drain Current (pulsed)				240	A
$V_{SD(1)}$	Forward On Voltage	$I_{SD} = 60\text{ A}$, $V_{GS} = 0$			1.5	V
t_{rr}	Reverse Recovery Time	$I_{SD} = 60\text{ A}$, $di/dt = 100\text{ A}/\mu\text{s}$		50		ns
Q_{rr}	Reverse Recovery Charge	$V_{DD} = 15\text{ V}$, $T_j = 150^\circ\text{C}$ (see test circuit, Figure 5)		62		nC
I_{RRM}	Reverse Recovery Current			2.6		A

Note: 1. Pulsed: Pulse duration = 300 μs , duty cycle 1.5 %.
2. Pulse width limited by safe operating area.

Safe Operating Area

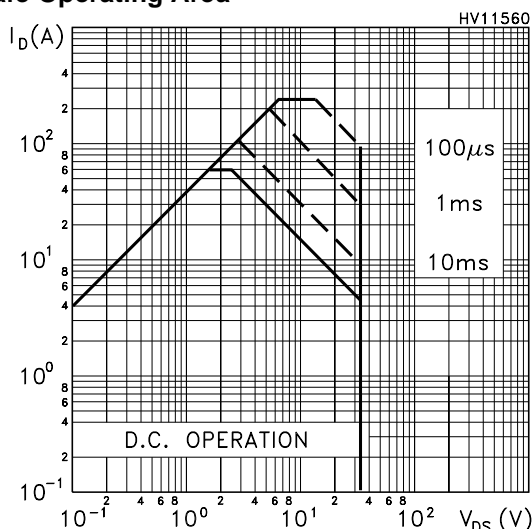

Thermal Impedance

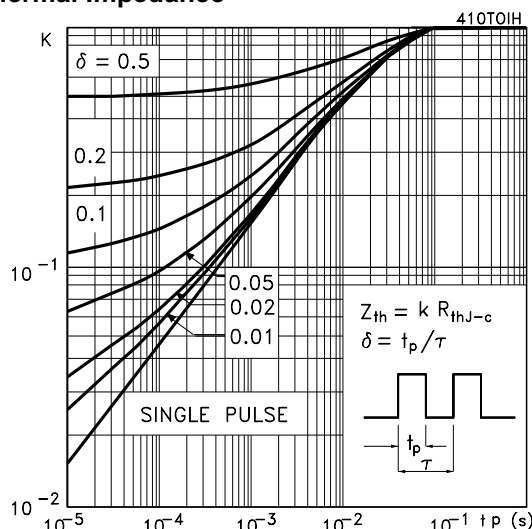

STP60NS04ZB

Output Characteristics

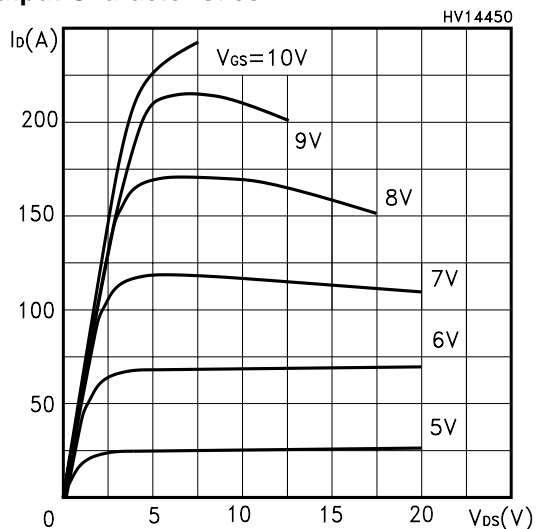

Transfer Characteristics

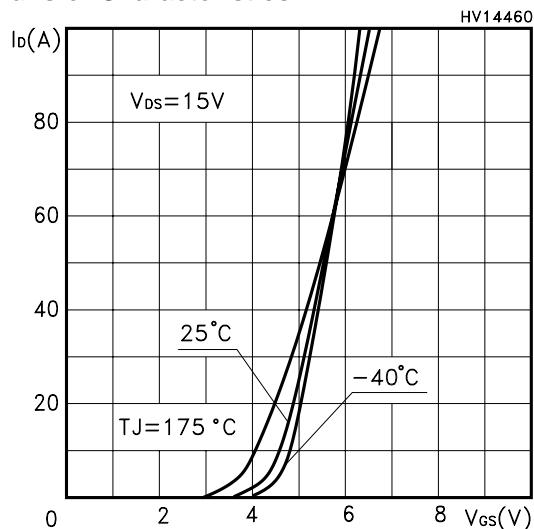

Transconductance

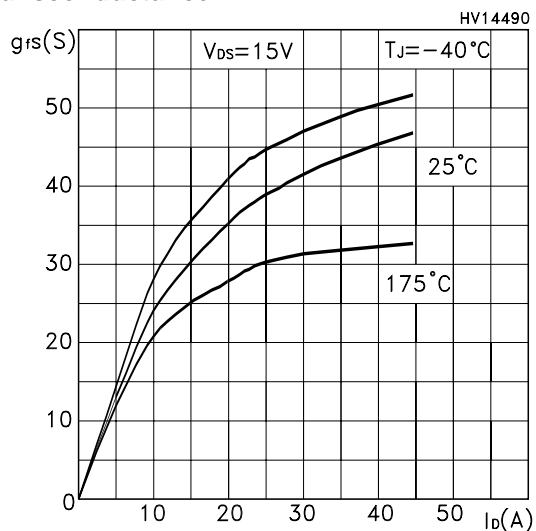

Static Drain-source On Resistance

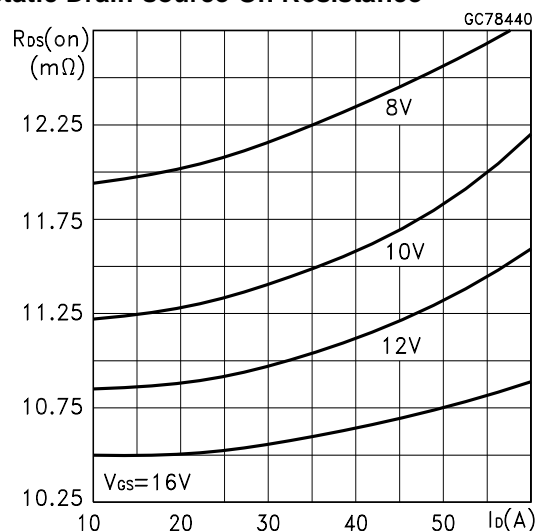

Gate Charge vs Gate-source Voltage

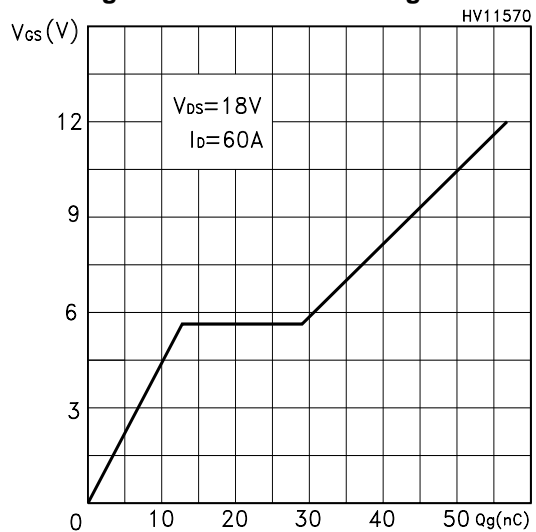

Capacitance Variations

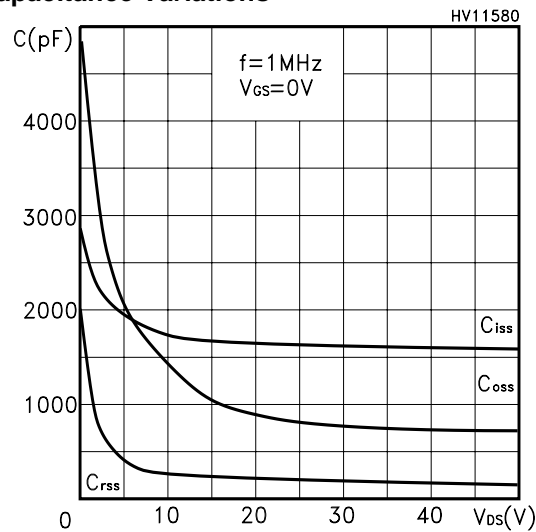

Normalized Gate Threshold Voltage vs Temp.

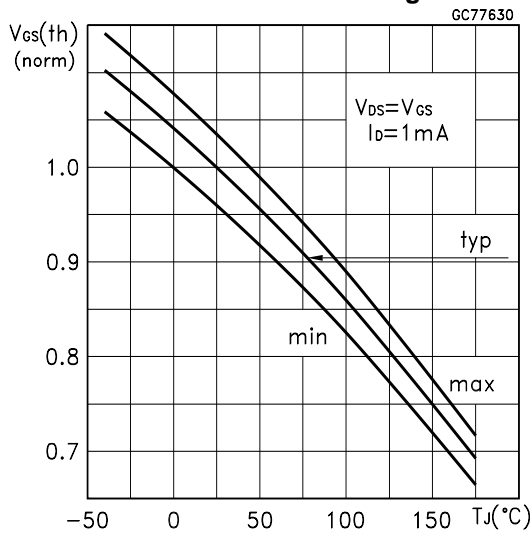

Normalized On Resistance vs Temperature

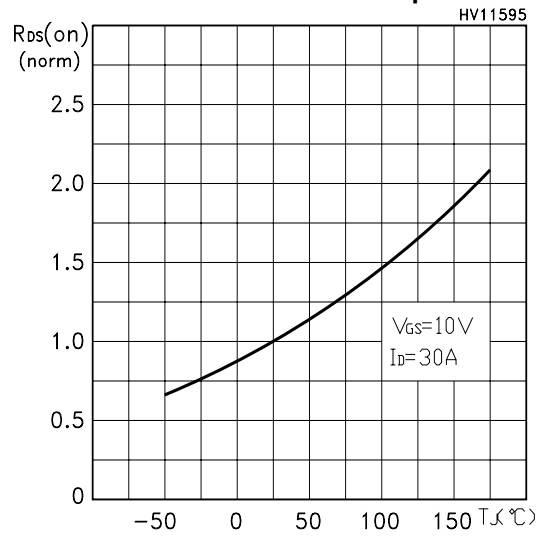

Zero Gate Voltage Drain Current vs Temperature

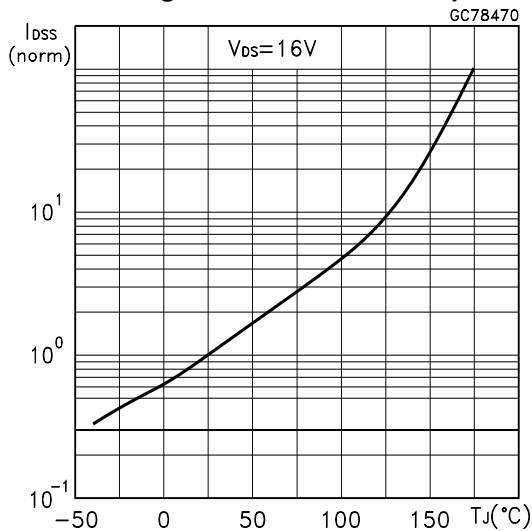

Source-drain Diode Forward Characteristics

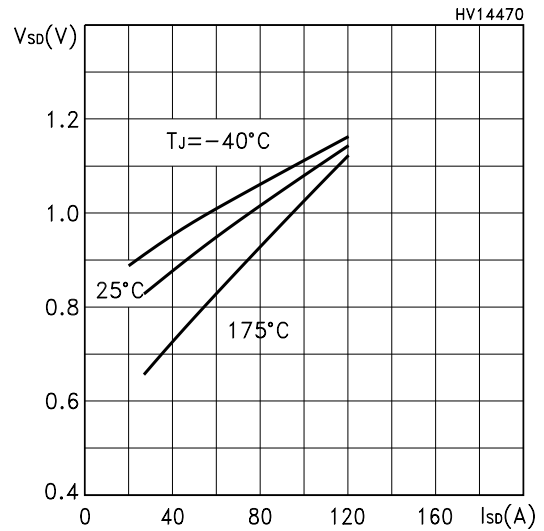

Normalized BVDSS vs Temperature

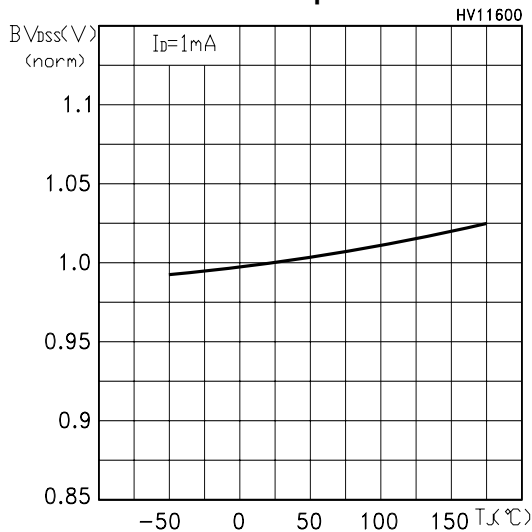

Fig. 1: Unclamped Inductive Load Test Circuit

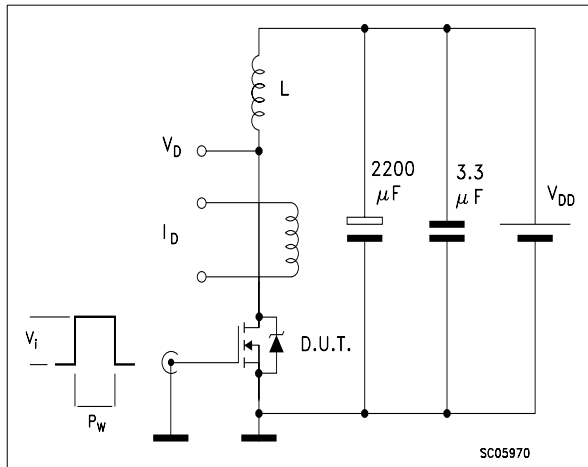

Fig. 2: Unclamped Inductive Waveform

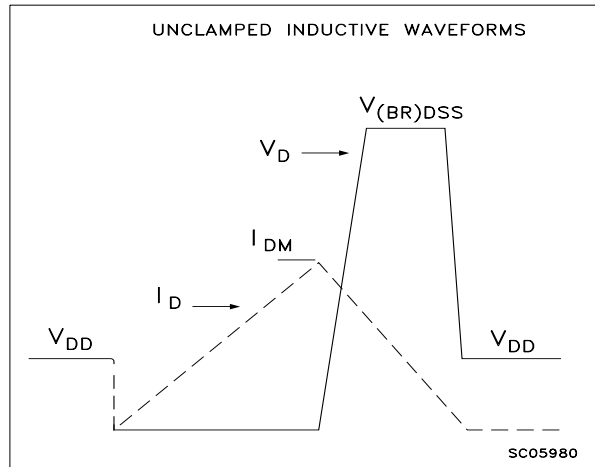

Fig. 3: Switching Times Test Circuit For Resistive Load

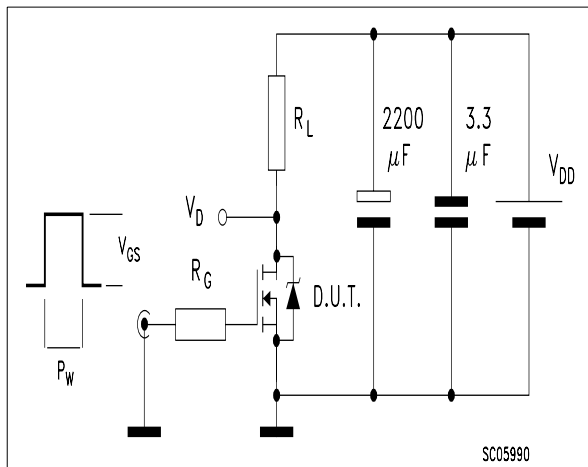

Fig. 4: Gate Charge test Circuit

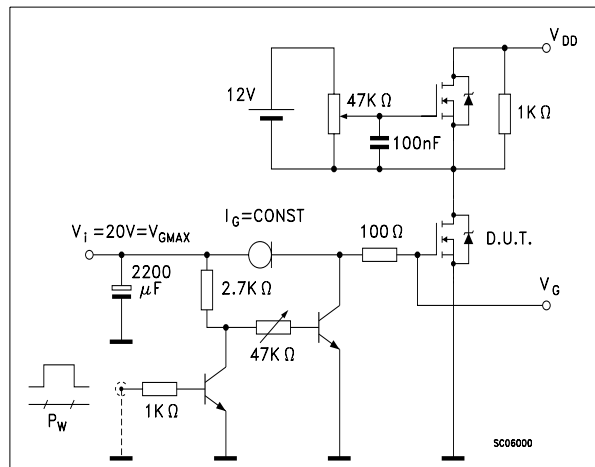
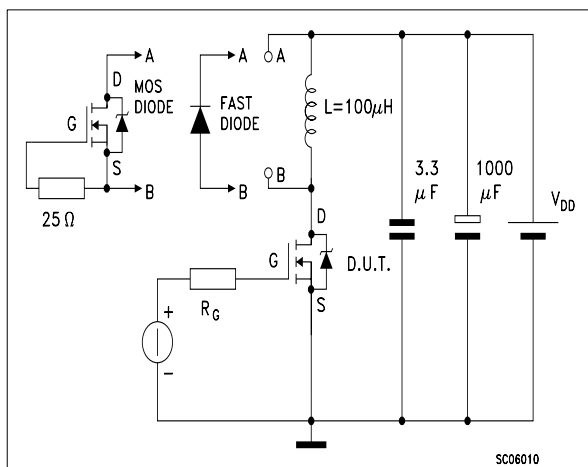
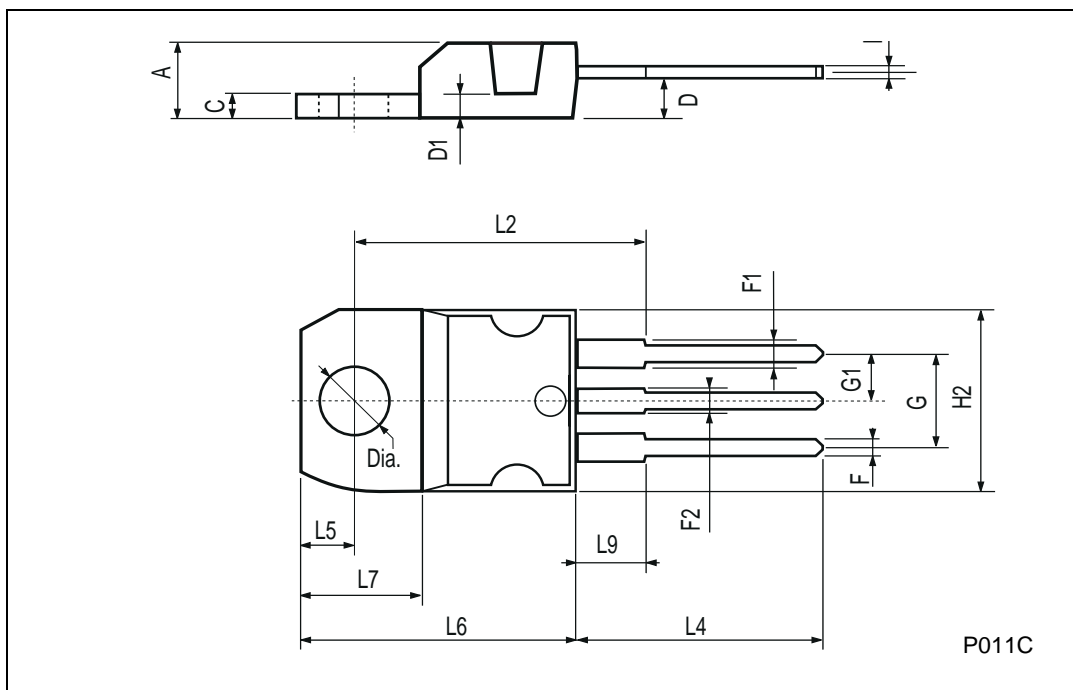

Fig. 5: Test Circuit For Inductive Load Switching And Diode Recovery Times



TO-220 MECHANICAL DATA

DIM.	mm			inch		
	MIN.	TYP.	MAX.	MIN.	TYP.	MAX.
A	4.40		4.60	0.173		0.181
C	1.23		1.32	0.048		0.051
D	2.40		2.72	0.094		0.107
D1		1.27			0.050	
E	0.49		0.70	0.019		0.027
F	0.61		0.88	0.024		0.034
F1	1.14		1.70	0.044		0.067
F2	1.14		1.70	0.044		0.067
G	4.95		5.15	0.194		0.203
G1	2.4		2.7	0.094		0.106
H2	10.0		10.40	0.393		0.409
L2		16.4			0.645	
L4	13.0		14.0	0.511		0.551
L5	2.65		2.95	0.104		0.116
L6	15.25		15.75	0.600		0.620
L7	6.2		6.6	0.244		0.260
L9	3.5		3.93	0.137		0.154
DIA.	3.75		3.85	0.147		0.151



Information furnished is believed to be accurate and reliable. However, STMicroelectronics assumes no responsibility for the consequences of use of such information nor for any infringement of patents or other rights of third parties which may result from its use. No license is granted by implication or otherwise under any patent or patent rights of STMicroelectronics. Specifications mentioned in this publication are subject to change without notice. This publication supersedes and replaces all information previously supplied. STMicroelectronics products are not authorized for use as critical components in life support devices or systems without express written approval of STMicroelectronics.

© The ST logo is a registered trademark of STMicroelectronics

© 2002 STMicroelectronics - Printed in Italy - All Rights Reserved
STMicroelectronics GROUP OF COMPANIES

Australia - Brazil - Canada - China - Finland - France - Germany - Hong Kong - India - Israel - Italy - Japan - Malaysia - Malta - Morocco
Singapore - Spain - Sweden - Switzerland - United Kingdom - United States.

© <http://www.st.com>