



### General Description

AFP2323A, P-Channel enhancement mode MOSFET, uses Advanced Trench Technology to provide excellent  $R_{DS(ON)}$ , low gate charge.

These devices are particularly suited for low voltage power management, and low in-line power loss are needed in commercial industrial surface mount applications.

### Features

- -30V/-2.8A,  $R_{DS(ON)}=155m\Omega@V_{GS}=-10.0V$
- -30V/-2.4A,  $R_{DS(ON)}=240m\Omega@V_{GS}=-4.5V$
- Super high density cell design for extremely low  $R_{DS(ON)}$
- Exceptional on-resistance and maximum DC current capability
- SOT-23 package design

### Pin Description ( SOT-23 )

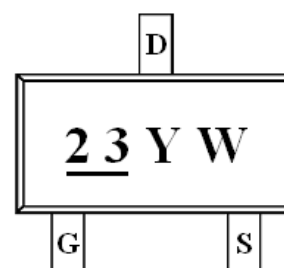
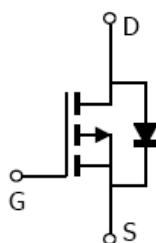
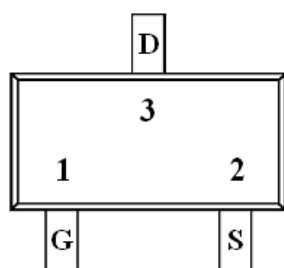

### Application

- Battery Switch for Portable Devices
- Computers
  - Bus Switch
  - Load Switch LED Display

### Pin Define

Pin	Symbol	Description
1	G	Gate
2	S	Source
3	D	Drain

### Ordering Information

Part Ordering No.	Part Marking	Package	Unit	Quantity
AFP2323AS23RG	23YW	SOT-23	Tape & Reel	3000 EA

- ※ 23 parts code
- ※ Y year code ( 0 ~ 9 )
- ※ W week code ( A ~ Z = 1 ~ 26 / a ~ z = 27 ~ 52 )
- ※ AFP2323AS23RG : 7" Tape & Reel ; Pb- Free ; Halogen- Free



### Absolute Maximum Ratings

( $T_A=25^{\circ}\text{C}$  Unless otherwise noted)

Parameter	Symbol	Typical	Unit
Drain-Source Voltage	$V_{DSS}$	-30	V
Gate –Source Voltage	$V_{GSS}$	$\pm 20$	V
Continuous Drain Current( $T_J=150^{\circ}\text{C}$ )	$I_D$	$T_A=25^{\circ}\text{C}$	-3.6
		$T_A=70^{\circ}\text{C}$	-2.4
Pulsed Drain Current	$I_{DM}$	-15	A
Continuous Source Current(Diode Conduction)	$I_S$	-1.5	A
Power Dissipation	$P_D$	$T_A=25^{\circ}\text{C}$	1.25
		$T_A=70^{\circ}\text{C}$	0.8
Operating Junction Temperature	$T_J$	150	$^{\circ}\text{C}$
Storage Temperature Range	$T_{STG}$	-55/150	$^{\circ}\text{C}$
Thermal Resistance-Junction to Ambient	$R_{\theta JA}$	120	$^{\circ}\text{C}/\text{W}$

### Electrical Characteristics

( $T_A=25^{\circ}\text{C}$  Unless otherwise noted)

Parameter	Symbol	Conditions	Min.	Typ	Max.	Unit
<b>Static</b>						
Drain-Source Breakdown Voltage	$V_{(BR)DSS}$	$V_{GS}=0\text{V}, I_D=-250\mu\text{A}$	-30			V
Gate Threshold Voltage	$V_{GS(th)}$	$V_{DS}=V_{GS}, I_D=-250\mu\text{A}$	-1.0		-2.6	V
Gate Leakage Current	$I_{GSS}$	$V_{DS}=0\text{V}, V_{GS}=\pm 20\text{V}$			$\pm 100$	nA
Zero Gate Voltage Drain Current	$I_{DSS}$	$V_{DS}=-24\text{V}, V_{GS}=0\text{V}$			-1	uA
		$V_{DS}=-24\text{V}, V_{GS}=0\text{V}$ $T_A=85^{\circ}\text{C}$			-30	
On-State Drain Current	$I_{D(on)}$	$V_{DS} \leq -5\text{V}, V_{GS}=-10\text{V}$	-10			A
Drain-Source On-Resistance	$R_{DS(on)}$	$V_{GS}=-10.0\text{V}, I_D=-2.8\text{A}$		140	155	m $\Omega$
		$V_{GS}=-4.5\text{V}, I_D=-2.4\text{A}$		220	240	
Forward Transconductance	$g_{FS}$	$V_{DS}=-5\text{V}, I_D=-4.0\text{A}$		10		S
Diode Forward Voltage	$V_{SD}$	$I_S=-1.5\text{A}, V_{GS}=0\text{V}$		-0.7	-1.3	V
<b>Dynamic</b>						
Total Gate Charge	$Q_g$	$V_{DS}=-15\text{V}, V_{GS}=-4.5\text{V}$ $I_D \equiv -2.5\text{A}$		2.5		nC
Gate-Source Charge	$Q_{gs}$			0.8		
Gate-Drain Charge	$Q_{gd}$			1.0		
Input Capacitance	$C_{iss}$	$V_{DS}=-15\text{V}, V_{GS}=0\text{V}$ $f=1\text{MHz}$		170		pF
Output Capacitance	$C_{oss}$			50		
Reverse Transfer Capacitance	$C_{rss}$			30		
Turn-On Time	$t_{d(on)}$	$V_{DD}=-15\text{V}, R_L=7.5\Omega$ $I_D \equiv -2.0\text{A}, V_{GEN}=-10\text{V}$ $R_G=1\Omega$		5	10	ns
	$t_r$			10	16	
Turn-Off Time	$t_{d(off)}$			10	16	
	$t_f$			5	10	



## Typical Characteristics

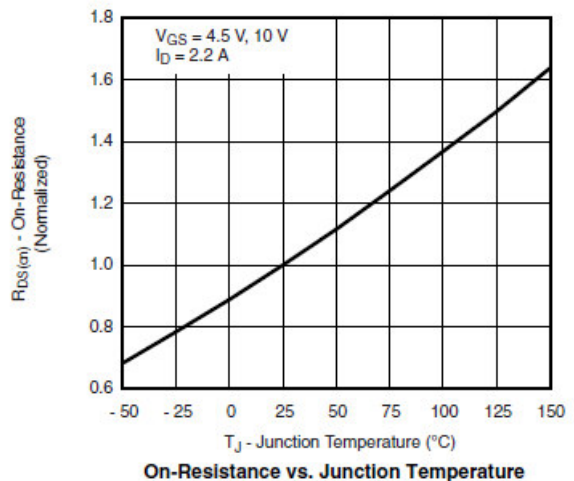
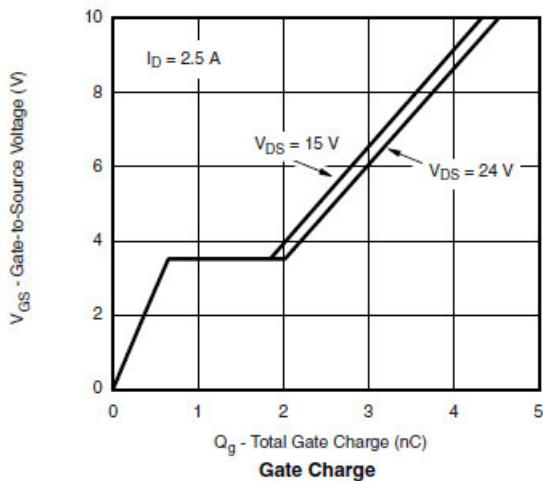
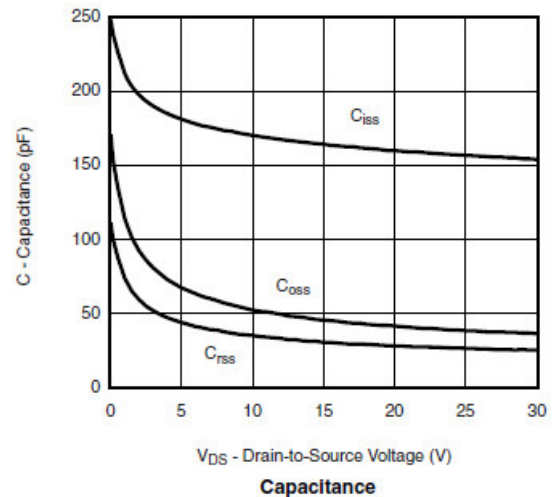
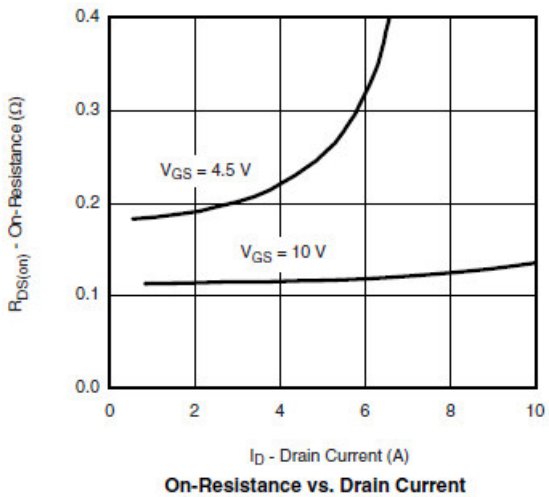
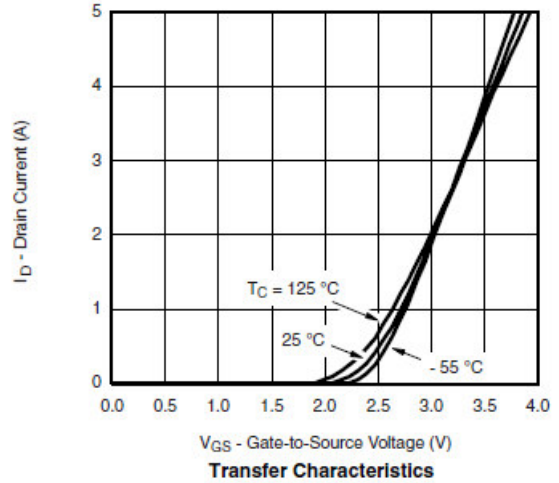
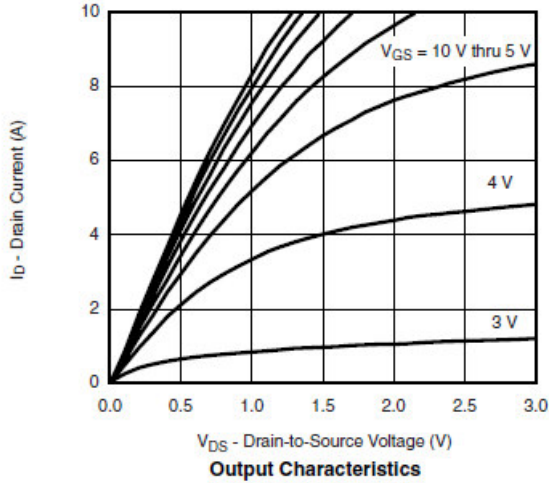



**Typical Characteristics**

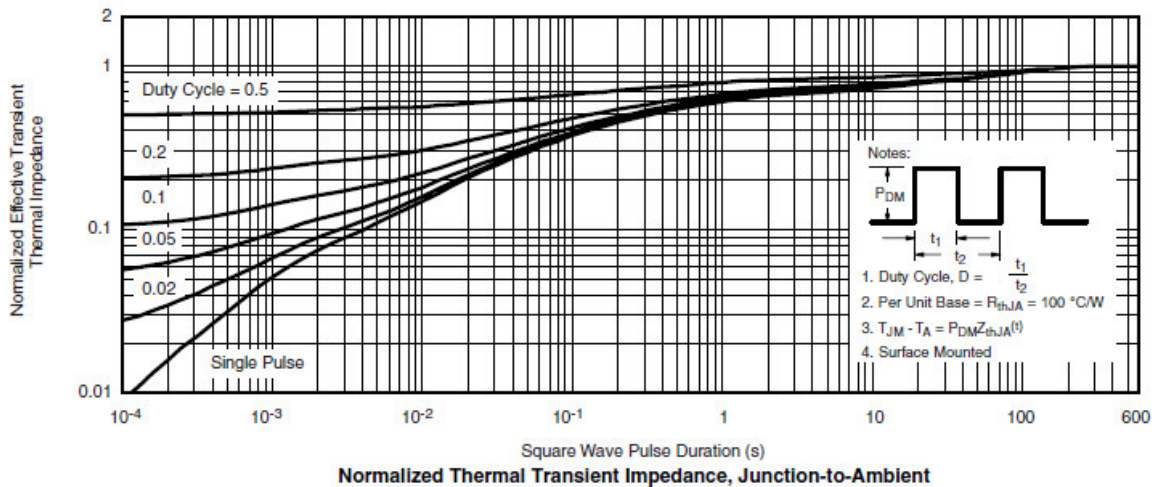
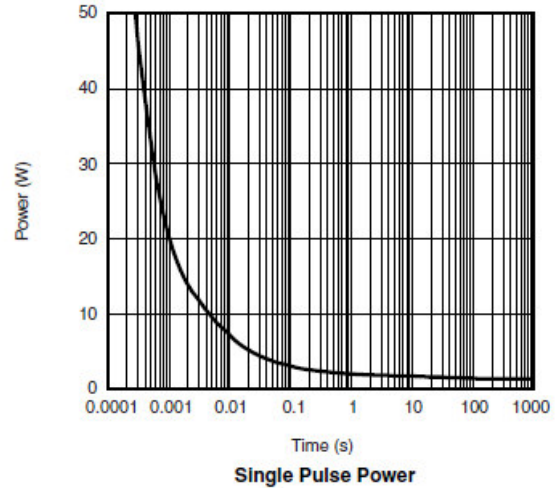
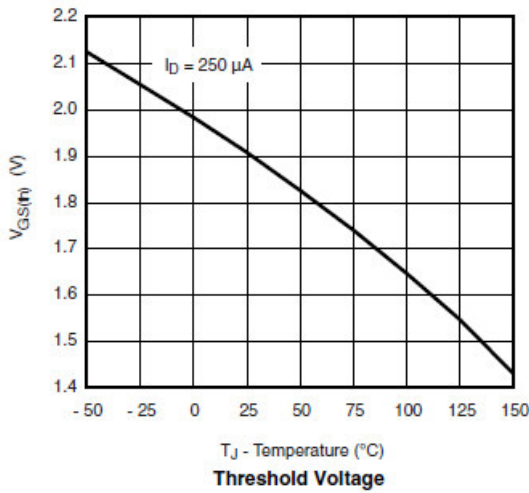
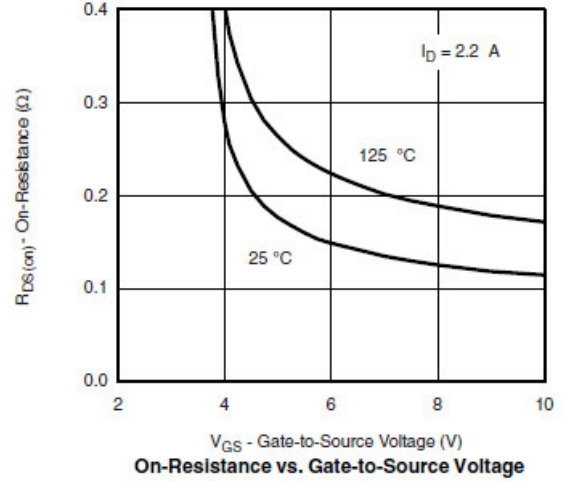
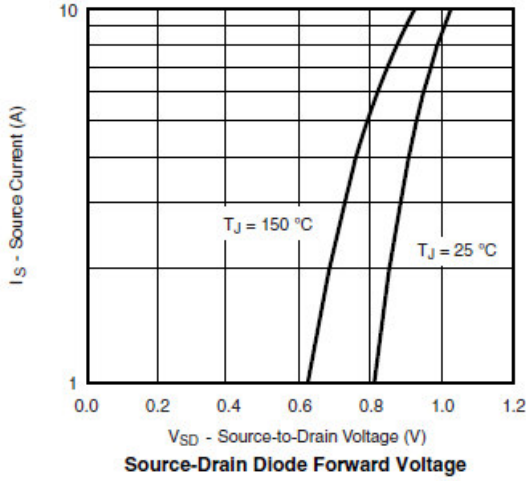



**Typical Characteristics**

Gate Charge Test Circuit & Waveform

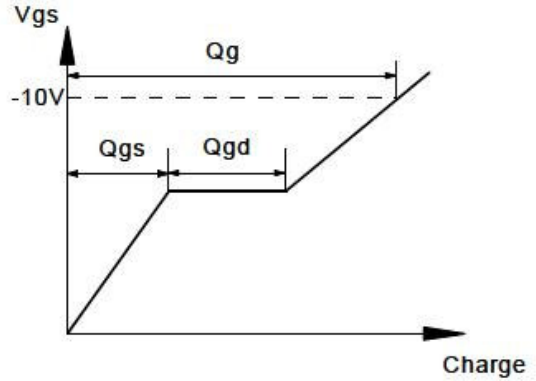
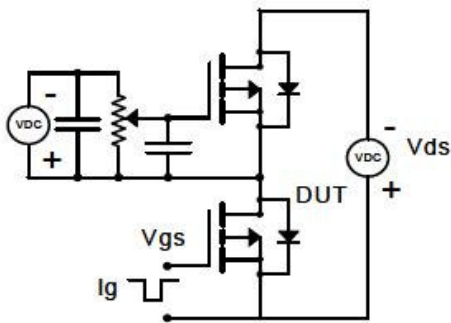

Resistive Switching Test Circuit & Waveforms

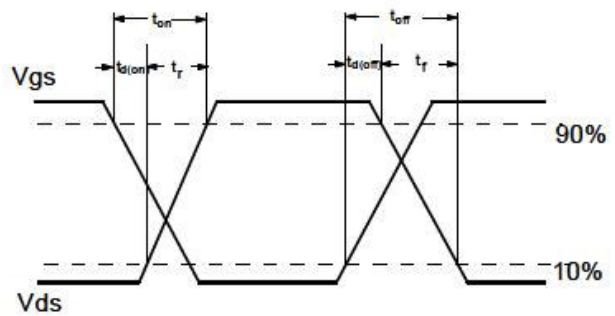
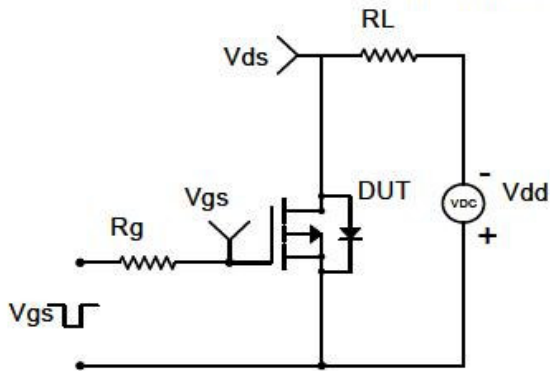

Diode Recovery Test Circuit & Waveforms

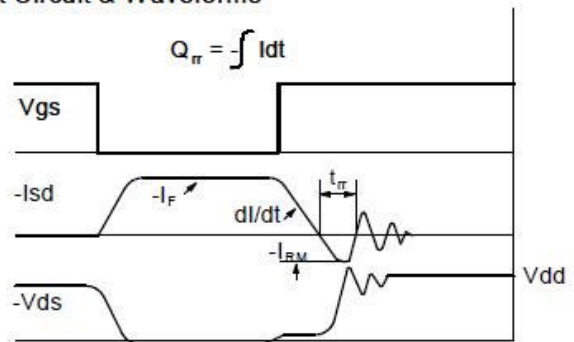
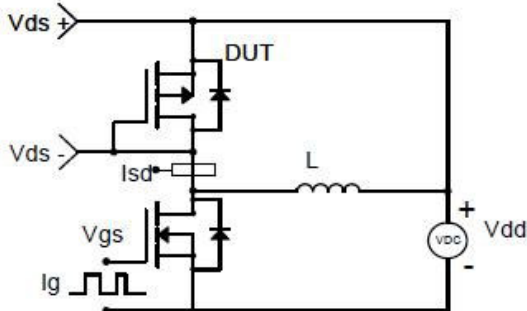



**Package Information ( SOT-23 )**

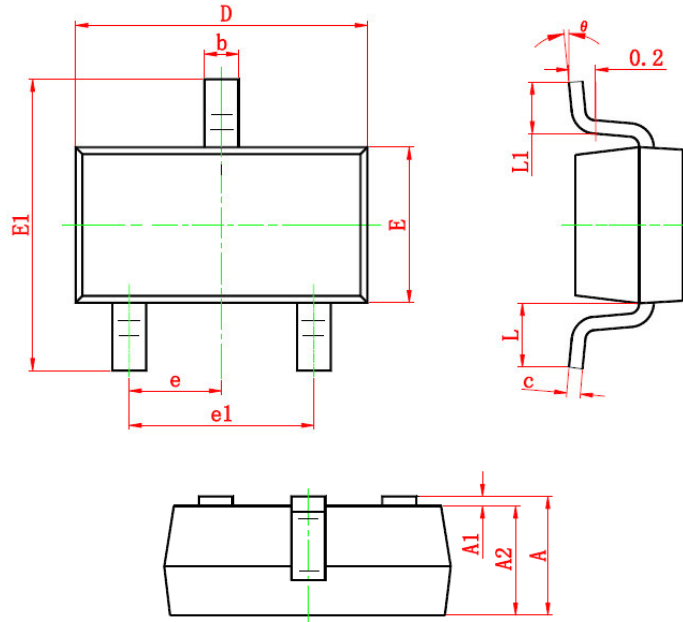

Symbol	Dimensions In Millimeters		Dimensions In Inches	
	Min	Max	Min	Max
A	0.900	1.200	0.035	0.043
A1	0.000	0.100	0.000	0.004
A2	0.900	1.100	0.035	0.039
b	0.300	0.500	0.012	0.020
c	0.080	0.150	0.003	0.006
D	2.800	3.000	0.110	0.118
E	1.200	1.400	0.047	0.055
E1	2.250	2.550	0.089	0.100
e	0.950 TYP		0.037 TYP	
e1	1.800	2.000	0.071	0.079
L	0.550 REF		0.022 REF	
L1	0.300	0.500	0.012	0.020
theta	0°	8°	0°	6°

©2010 Alfa-MOS Technology Corp.  
 2F, No.80, Sec.1, Cheng Kung Rd., Nan Kang Dist., Taipei City 115, Taiwan (R.O.C.)  
 Tel : 886 2) 2651 3928  
 Fax : 886 2) 2786 8483  
 ©http://www.alfa-mos.com