



General Description

AFN10N65 is an N-channel enhancement mode Power MOSFET which is produced using VDMOS technology. The improved planar stripe cell and the improved guard ring terminal have been especially tailored to minimize on-state resistance, provide superior switching performance, and withstand high energy pulse in the avalanche and commutation mode.

These devices are widely used in AC-DC power suppliers, DC-DC converters and H-bridge PWM motor drivers.

Features

- 650V/5A, $R_{DS(ON)}=1\Omega_{(MAX)}@V_{GS}=10V$
- Low gate charge
- Low Crss
- Fast switching
- Improved dv/dt capability

Application

- AC-DC Switching Power Supply
- LCD / LED / PDP TV Lighting
- Solar Inverter

Pin Description

SYMBOL

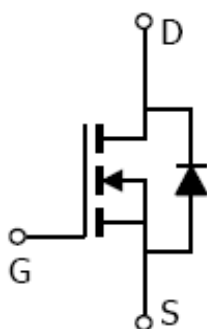

TO-220-3L

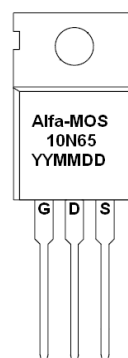

TO-220F-3L

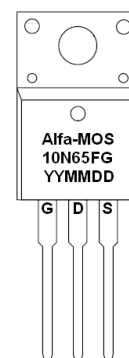

Absolute Maximum Ratings

($T_c=25^\circ\text{C}$ Unless otherwise noted)

Parameter	Symbol	Typical		Unit
		TO-220-3L	TO-220F-3L	
Drain-Source Voltage	V_{DSS}	650		V
Gate -Source Voltage	V_{GSS}	± 30		V
Continuous Drain Current	I_D	$T_c=25^\circ\text{C}$		A
		$T_c=100^\circ\text{C}$		A
Pulsed Drain Current	I_{DM}	40		A
Single Pulsed Avalanche Energy $L=30\text{mH}$, $I_{AS}=5.82\text{A}$, $V_{DD}=150\text{V}$, $R_G=25\Omega$, starting $T_J=25^\circ\text{C}$	E_{AS}	680		mJ
Power Dissipation	P_D	156	50	W
Power Dissipation Derate		$T_c=25^\circ\text{C}$	1.25	0.4
Operating Junction Temperature	T_J	-55/150		$^\circ\text{C}$
Storage Temperature Range	T_{STG}	-55/150		$^\circ\text{C}$
Thermal Resistance-Junction to Case	$R_{\theta JC}$	0.8	2.5	$^\circ\text{C}/\text{W}$
Thermal Resistance-Junction to Ambient	$R_{\theta JA}$	62.5	120	$^\circ\text{C}/\text{W}$



Pin Define

Pin	Symbol	Description
1	G	Gate
2	S	Source
3	D	Drain

Ordering Information

Part Ordering No.	Part Marking	Package	Material	Unit	Quantity
AFN10N65T220T	Alfa-MOS 10N65 YYMMDD	TO-220-3L	Pb Free	Tube	50 EA
AFN10N65T220FT	Alfa-MOS 10N65F YYMMDD	TO-220F-3L	Pb Free	Tube	50 EA
AFN10N65T220FTG	Alfa-MOS 10N65FG YYMMDD	TO-220F-3L	Halogen Free	Tube	50 EA

※ YYMMDD Date Code

Electrical Characteristics

(T_c:25°C Unless otherwise noted)

Parameter	Symbol	Conditions	Min.	Typ	Max.	Unit	
Static							
Drain-Source Breakdown Voltage	V _{(BR)DSS}	V _{GS} =0V, I _D =250μA	650			V	
Gate Threshold Voltage	V _{GS(th)}	V _{DS} =V _{GS} , I _D =250μA	2.0		4.0		
Gate Leakage Current	I _{GSS}	V _{DS} =0V, V _{GS} =±30V			±100	nA	
Zero Gate Voltage Drain Current	I _{DSS}	V _{DS} =650V, V _{GS} =0V			1.0	μA	
Drain-Source On-Resistance	R _{DS(on)}	V _{GS} =10V, I _D =5.0A		0.8	1.0	Ω	
Continuous Source Current	I _S	Integral Reverse p-n Junction Diode in the MOSFET			10	A	
Pulsed Source Current	I _{SM}				40	A	
Diode Forward Voltage	V _{SD}	I _S =10A, V _{GS} =0V			1.3	V	
Reverse Recovery Time	T _{rr}	I _S =10A, V _{GS} =0V, dI _F /dt=100A/μs		570.8		ns	
Reverse Recovery Charge	Q _{rr}	Pulse width ≤300μs, Duty cycle ≤2%		4.71		μC	
Dynamic							
Total Gate Charge	Q _g	V _{DS} =520V, V _{GS} =10V, I _D ≅10A Pulse width ≤300μs, Duty cycle ≤2%		20.00		nC	
Gate-Source Charge	Q _{gs}			7.47			
Gate-Drain Charge	Q _{gd}			6.48			
Input Capacitance	C _{iss}	V _{DS} =25V, V _{GS} =0V f=1MHz		1143.2		pF	
Output Capacitance	C _{oss}			128.8			
Reverse Transfer Capacitance	C _{rss}			3.5			
Turn-On Time	t _{d(on)}	V _{DD} =325V, I _D =10A, R _G =25Ω Pulse width ≤300μs, Duty cycle ≤2%		40.00		ns	
	t _r			73.67			
Turn-Off Time	t _{d(off)}				52.13		
	t _f				34.80		



Typical Characteristics

Figure 1. On-Region Characteristics

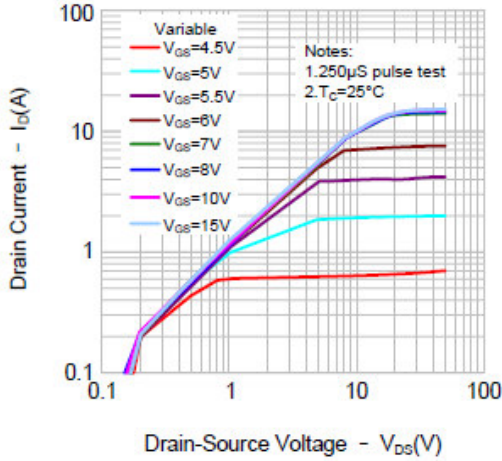

Figure 2. Transfer Characteristics

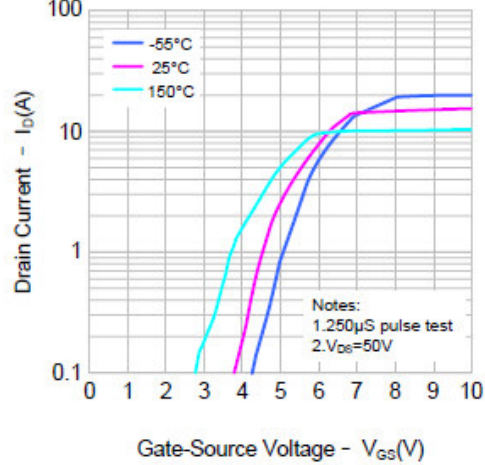

Figure 3. On-Resistance Variation vs. Drain Current and Gate Voltage

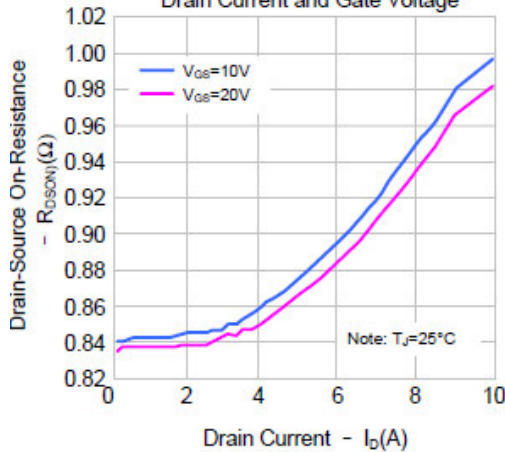

Figure 4. Body Diode Forward Voltage Variation vs. Source Current and Temperature

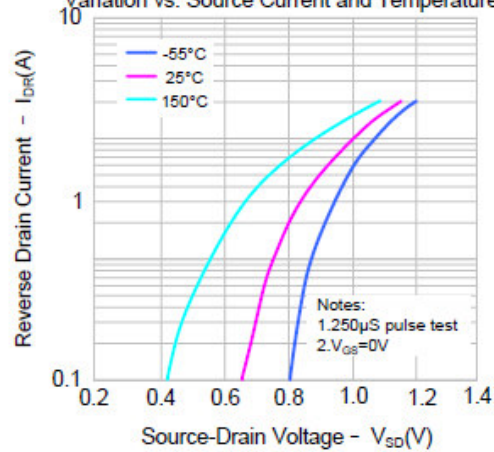

Figure 5. Capacitance Characteristics

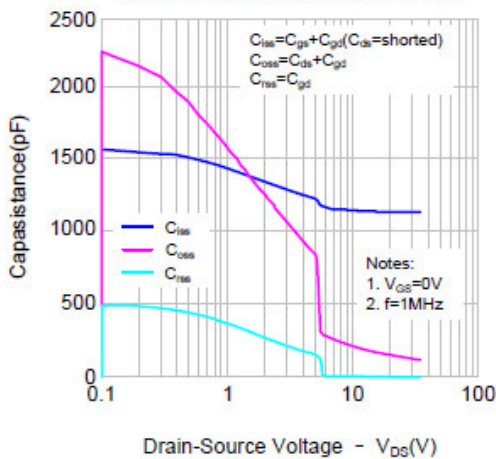
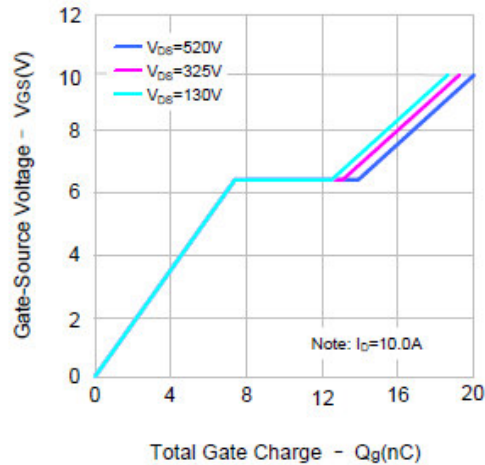
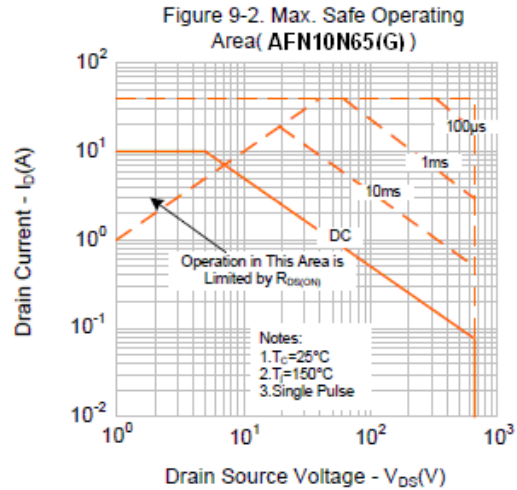
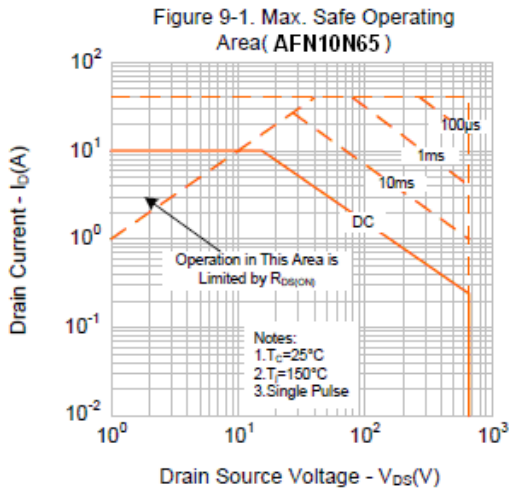
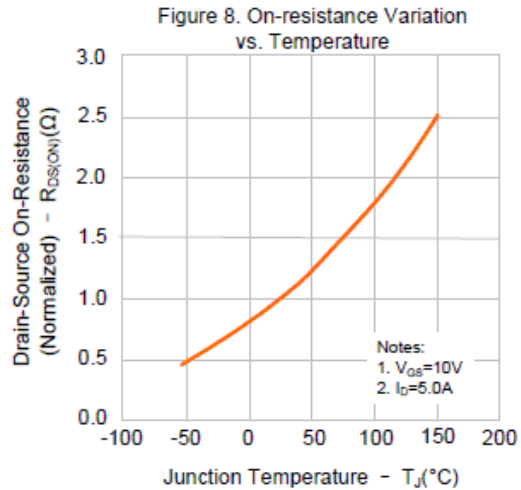
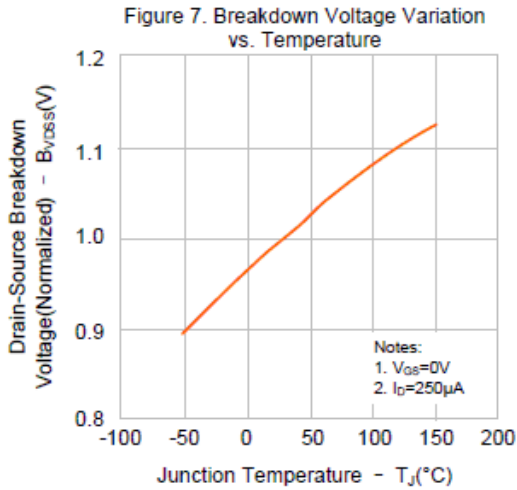

Figure 6. Gate Charge Characteristics





Typical Characteristics





Typical Characteristics

Gate Charge Test Circuit & Waveform

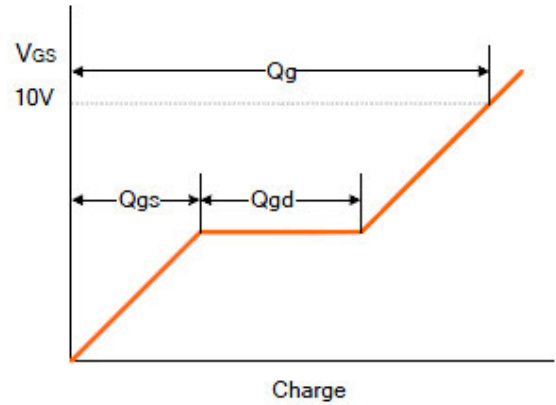
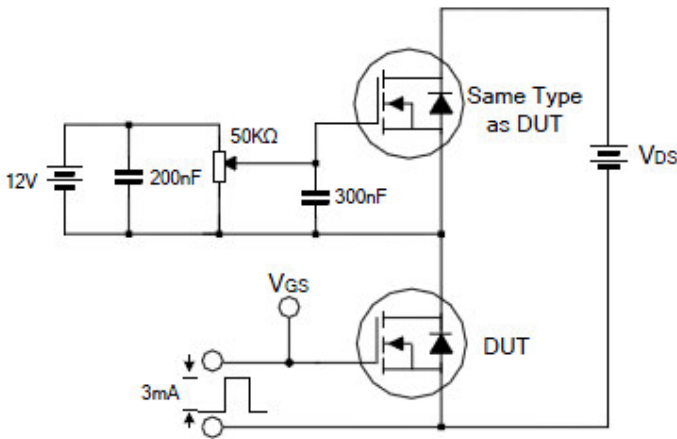

Resistive Switching Test Circuit & Waveform

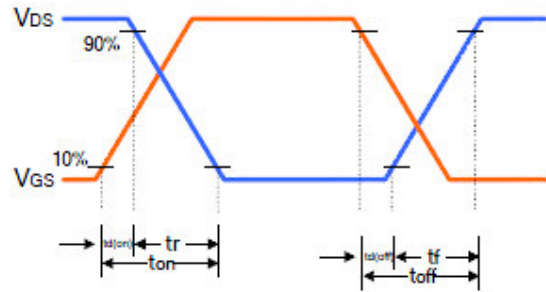
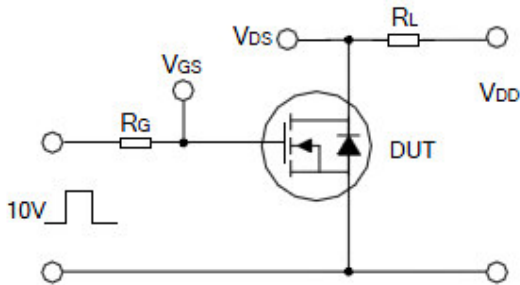

Unclamped Inductive Switching Test Circuit & Waveform

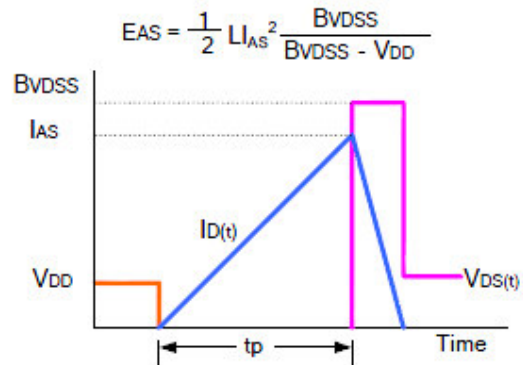
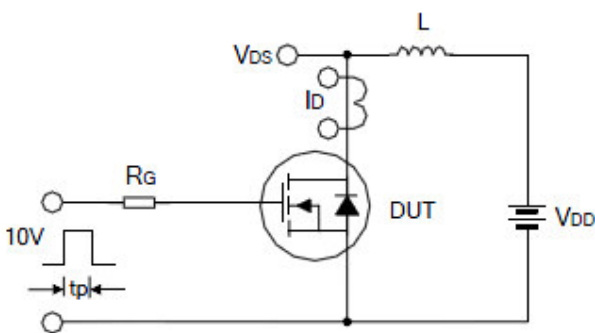



Package Information (TO-220-3L)

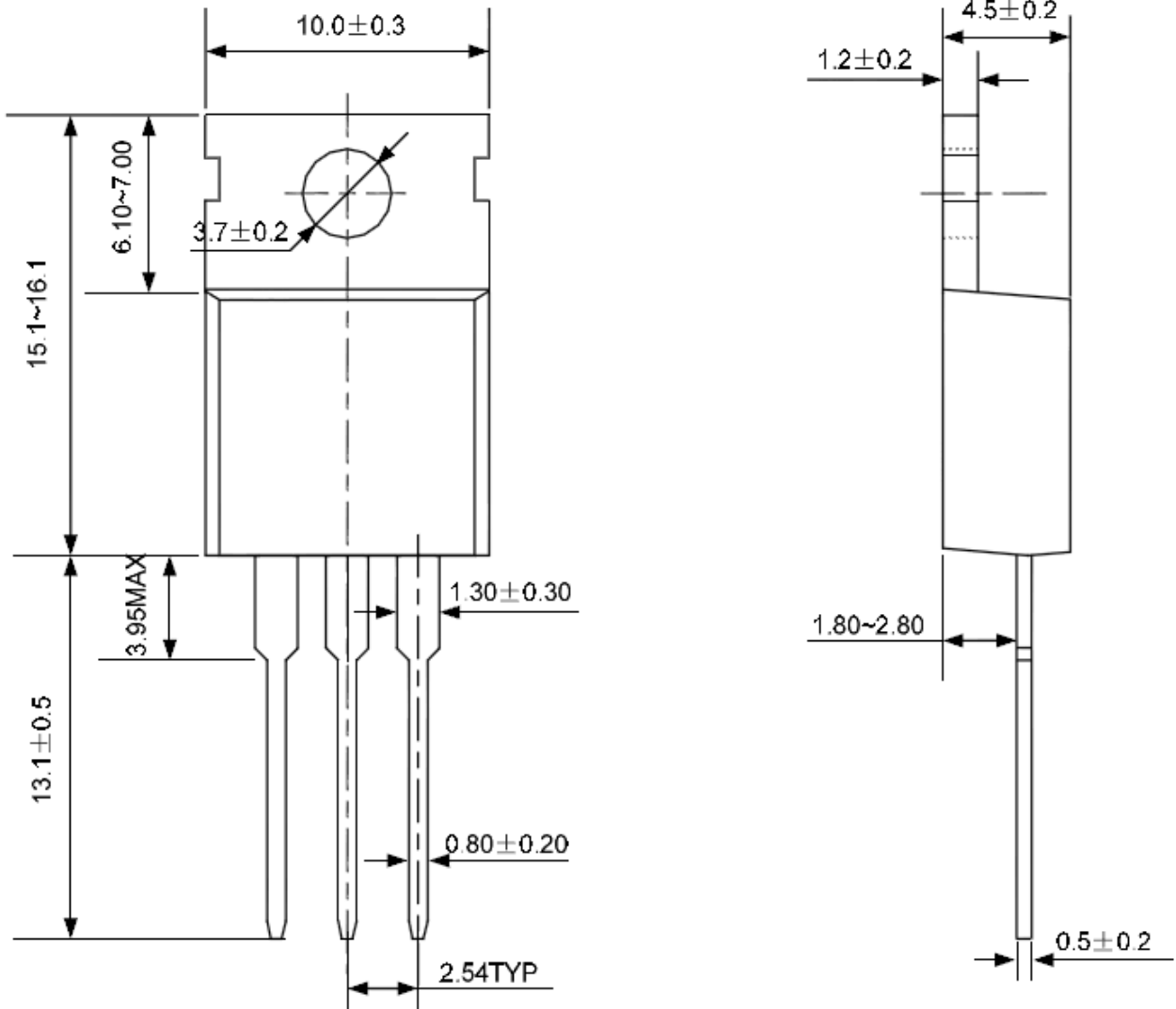

(Unit : mm)

©2010 Alfa-MOS Technology Corp.
2F, No.80, Sec.1, Cheng Kung Rd., Nan Kang Dist., Taipei City 115, Taiwan (R.O.C.)
Tel : 886 2) 2651 3928
Fax : 886 2) 2786 8483
©<http://www.alfa-mos.com>



Package Information (TO-220F-3L)

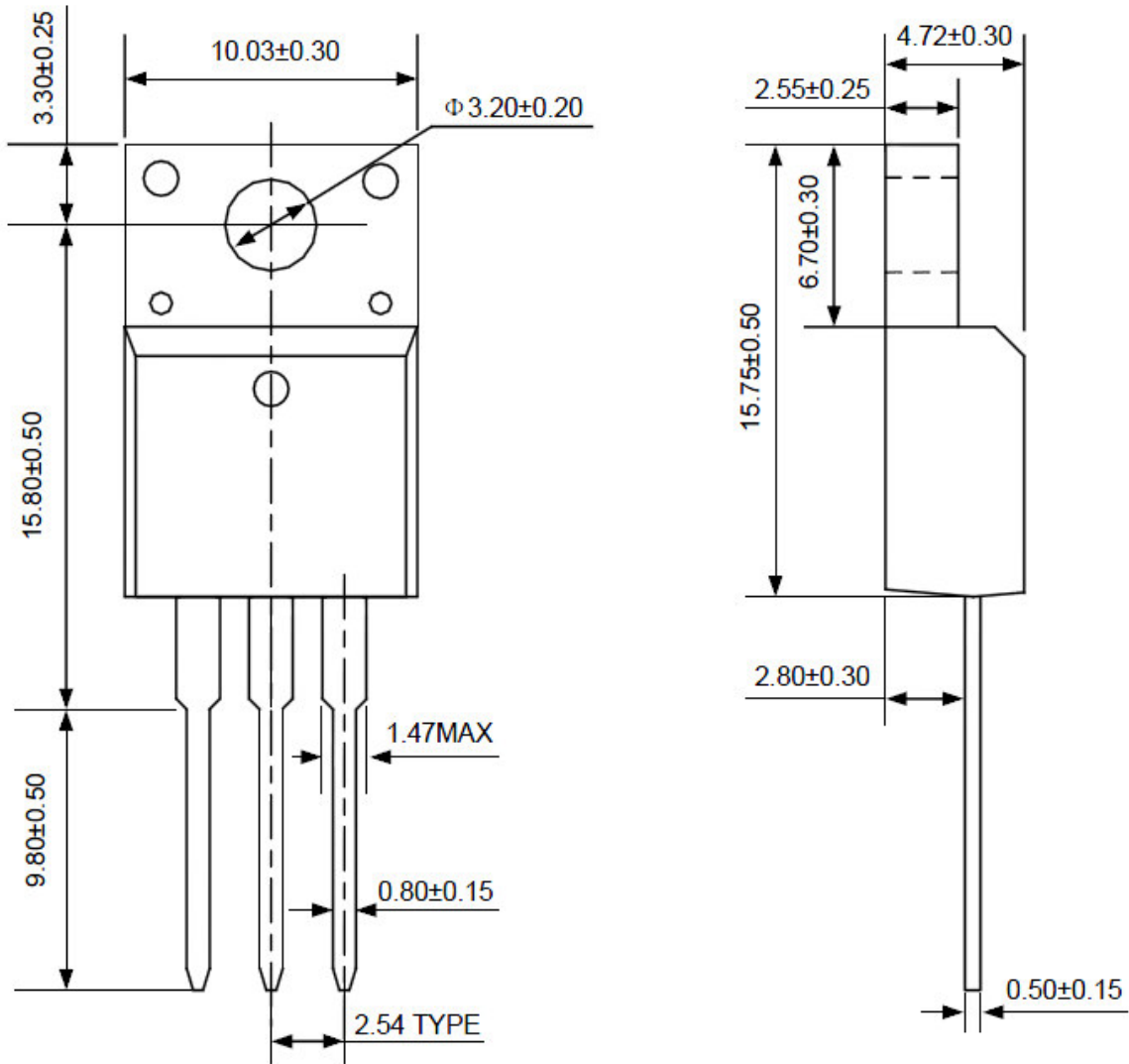

(Unit : mm)

©2010 Alfa-MOS Technology Corp.
2F, No.80, Sec.1, Cheng Kung Rd., Nan Kang Dist., Taipei City 115, Taiwan (R.O.C.)
Tel : 886 2) 2651 3928
Fax : 886 2) 2786 8483
©<http://www.alfa-mos.com>