



HD1750JL

Very high voltage NPN power transistor for high definition and slim CRT display

PRELIMINARY DATA

Features

- State-of-the-art technology: diffused collector “enhanced generation” EHVS1
- Wider range of optimum drive conditions
- Less sensitive to operating temperature variation
- In compliance with the 2002/93/EC European directive

Description

The HD1750JL is manufactured using Diffused Collector in Planar technology adopting new and Enhanced High Voltage Structure 1 (E.H.V.S.1) developed to fit High-Definition CRT display. The new HD product series show improved silicon efficiency bringing updated performance to the Horizontal Deflection stage.

Applications

- High-definition and slim CRT TV and monitors

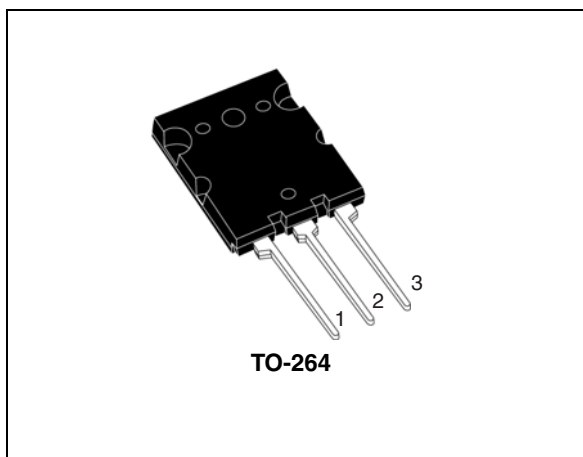

Internal schematic diagram

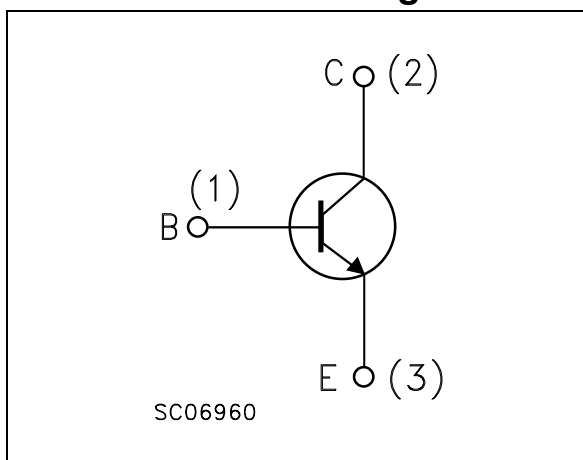

Order code

Part number	Marking	Package	Packaging
HD1750JL	HD1750JL	TO-264	Tube

1 Electrical ratings

Table 1. Absolute maximum ratings

Symbol	Parameter	Value	Unit
V_{CES}	Collector-emitter voltage ($V_{BE} = 0$)	1700	V
V_{CEO}	Collector-emitter voltage ($I_B = 0$)	800	V
V_{EBO}	Emitter-base voltage ($I_C = 0$)	10	V
I_C	Collector current	24	A
I_{CM}	Collector peak current ($t_P < 5\text{ms}$)	36	A
I_B	Base current	12	A
I_{BM}	Base peak current ($t_P < 5\text{ms}$)	18	A
P_{TOT}	Total dissipation at $T_C = 25^\circ\text{C}$	200	W
T_{STG}	Storage temperature	-65 to 150	$^\circ\text{C}$
T_J	Max. operating junction temperature	150	$^\circ\text{C}$

Table 2. Thermal data

Symbol	Parameter	Value	Unit
R_{thJ-C}	Thermal resistance junction-case max	0.625	$^\circ\text{C}/\text{W}$

2 Electrical characteristics

($T_{CASE}=25^{\circ}C$ unless otherwise specified)

Table 3. Electrical characteristics

Symbol	Parameter	Test conditions	Min.	Typ.	Max.	Unit
I_{CES}	Collector cut-off current ($V_{BE} = 0$)	$V_{CE} = 1700V$ $V_{CE} = 1700V; T_C = 125^{\circ}C$			0.2 2	mA mA
I_{EBO}	Emitter cut-off current ($I_C = 0$)	$V_{EB} = 5V$			10	μA
$V_{CEO(sus)}^{(1)}$	Collector-emitter sustaining voltage ($I_B = 0$)	$I_C = 10mA$	800			V
$V_{EBO}^{(1)}$	Emitter-base saturation voltage ($I_C = 0$)	$I_E = 10mA$	10			V
$V_{CE(sat)}^{(1)}$	Collector-emittersaturation voltage	$I_C = 12A; I_B = 3A$			3	V
$V_{BE(sat)}^{(1)}$	Base-emitter saturation voltage	$I_C = 12A; I_B = 3A$		0.95	1.5	V
h_{FE}	DC current gain	$I_C = 1A; V_{CE} = 5V$ $I_C = 12A; V_{CE} = 5V$	5.5	30	8.5	
t_s t_f	Inductive load Storage time Fall time	$I_C = 12A; I_{B(on)} = 1.8A$ $I_{B(off)} = -7.25A;$ $V_{CE(fly)} = 1320V;$ $V_{BE(off)} = -2.7V;$ $L_{BB(on)} = 0.8\mu H;$ $f_H = 31520Hz$		3 300	3.6 450	μs ns
t_s t_f	Inductive load Storage time Fall time	$I_C = 6.5A; I_{B(on)} = 1.1A$ $I_{B(off)} = -5.25A;$ $V_{CE(fly)} = 1220V;$ $V_{BE(off)} = -2.7V;$ $L_{BB(on)} = 0.25\mu H;$ $f_H = 100kHz$		1.6 110	2 220	μs ns

1. Pulsed: pulse duration = 300 μs , duty cycle < 2%

2.1 Electrical characteristics (curve)

Figure 1. Safe operating area

Figure 2. Derating curve

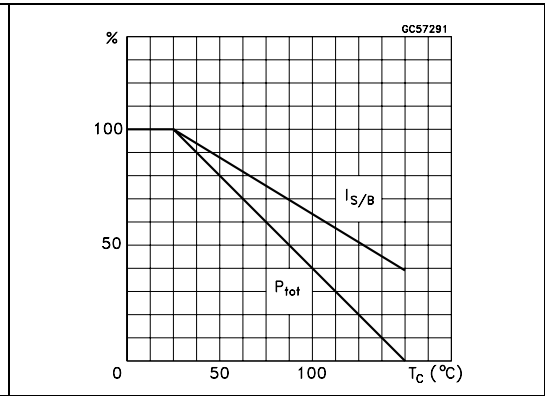
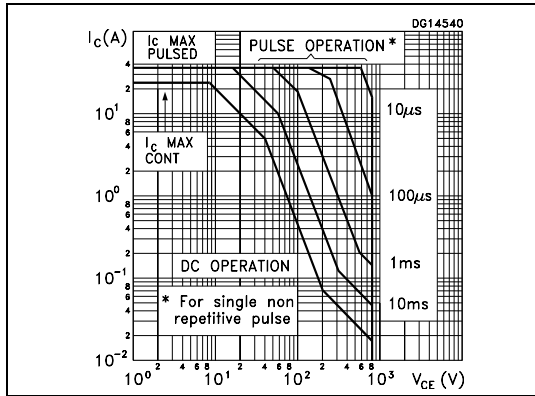

Figure 3. Output characteristics

Figure 4. Reverse biased SOA

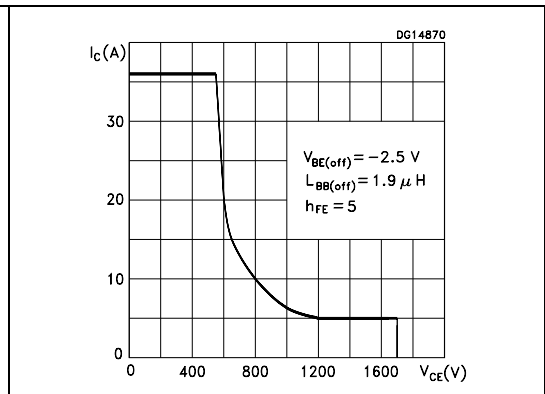
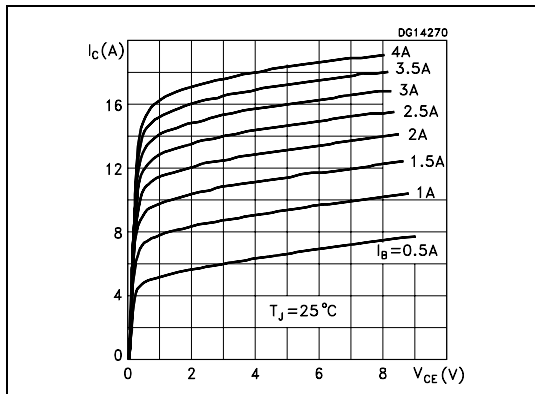

Figure 5. DC current gain

Figure 6. DC current gain

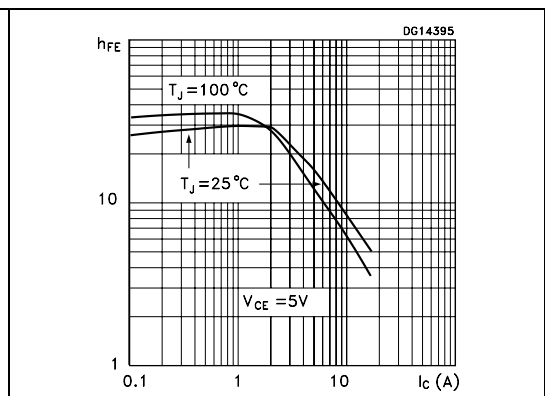
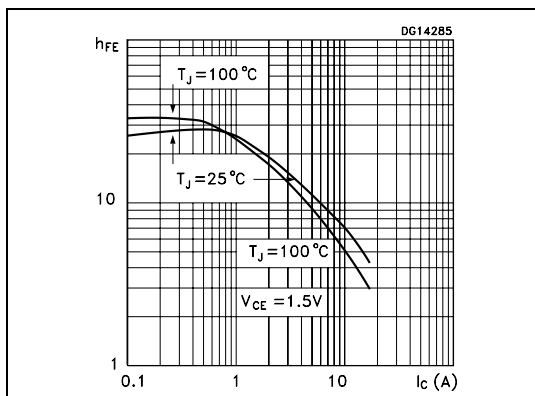

Figure 7. Collector-emitter saturation voltage

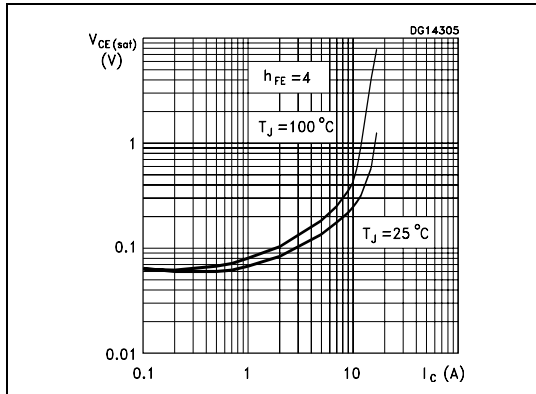

Figure 8. Base-emitter saturation voltage

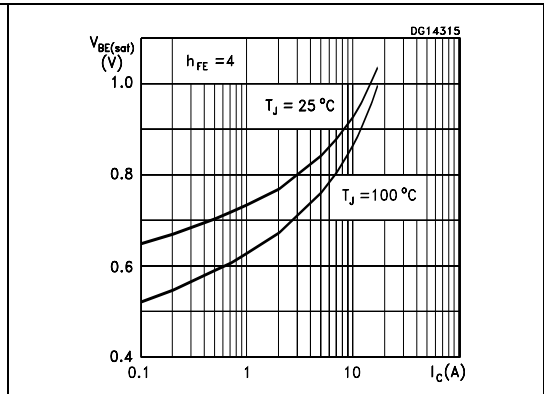

Figure 9. Power losses

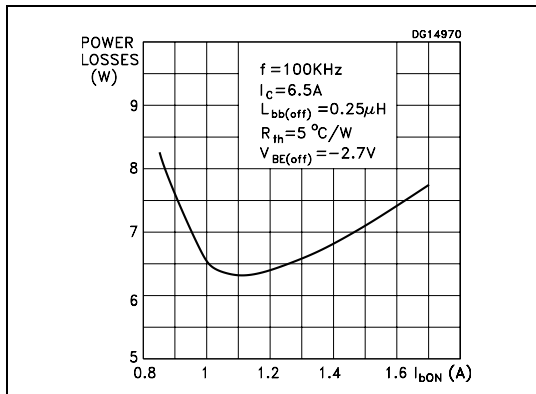

Figure 10. Power losses

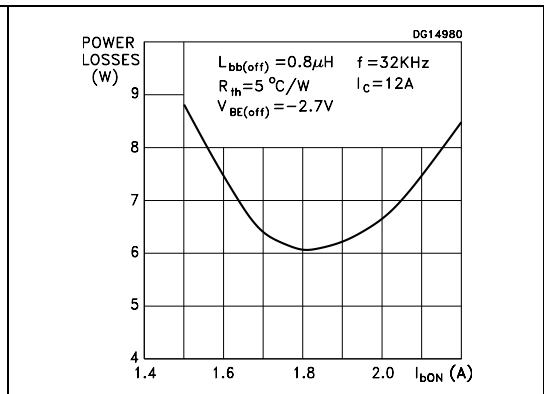

Figure 11. Inductive load switching time

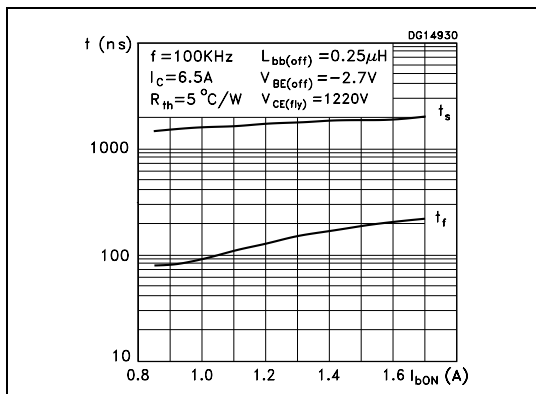
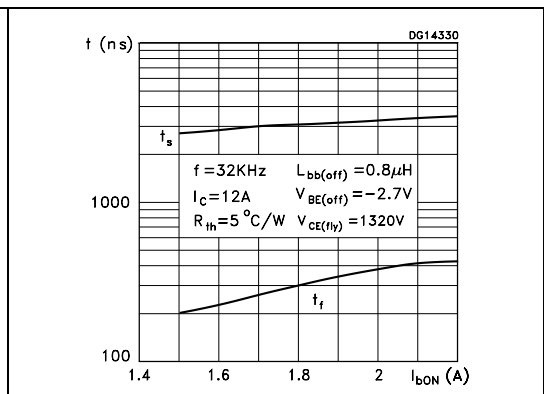

Figure 12. Inductive load switching time



3 Test circuit

Figure 13. Power losses and inductive load switching test circuit

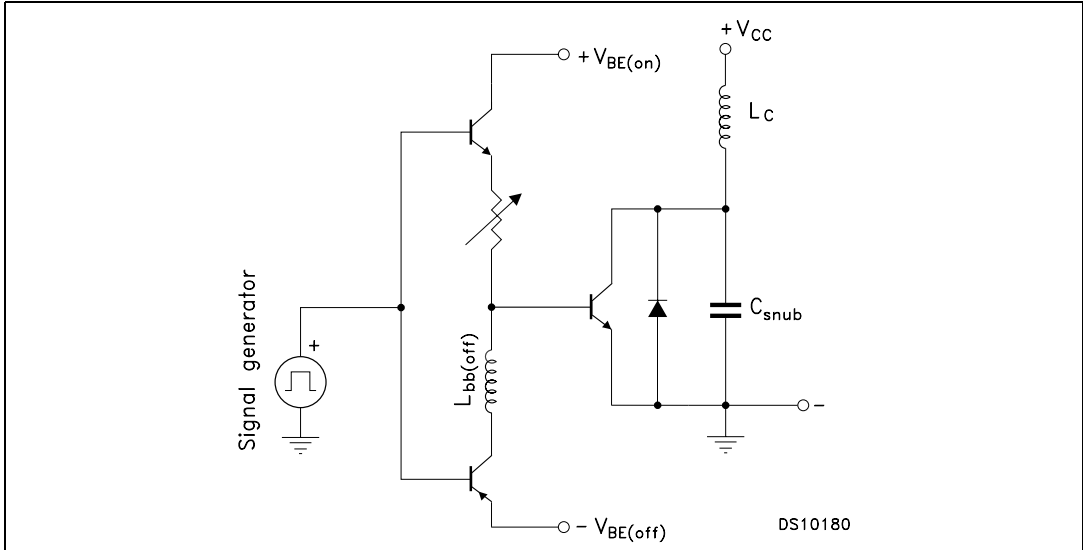
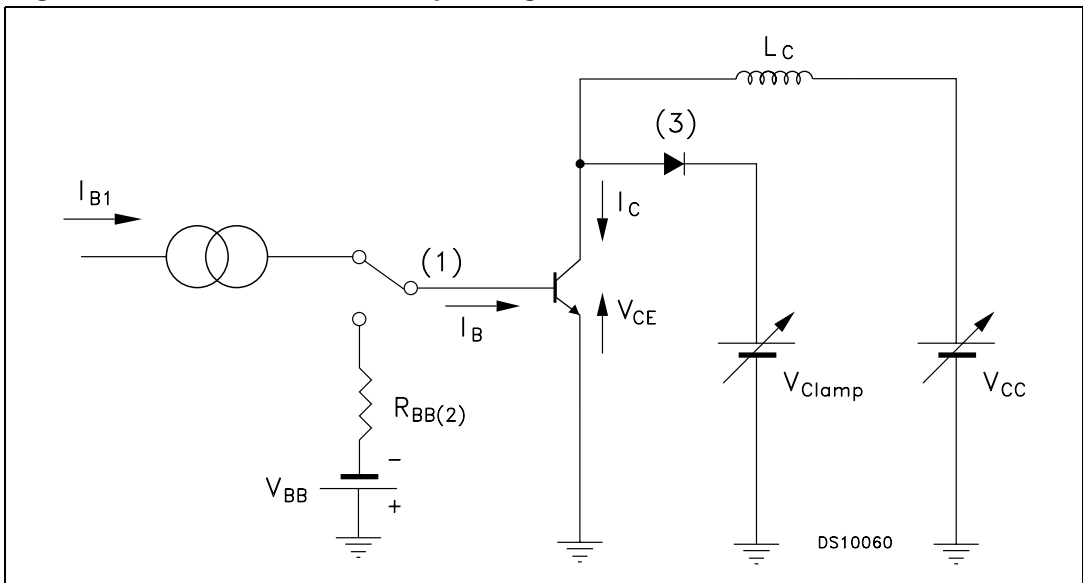

Figure 14. Reverse biased safe operating area test circuit



4 Package mechanical data

In order to meet environmental requirements, ST offers these devices in ECOPACK® packages. These packages have a Lead-free second level interconnect . The category of second level interconnect is marked on the package and on the inner box label, in compliance with JEDEC Standard JESD97. The maximum ratings related to soldering conditions are also marked on the inner box label. ECOPACK is an ST trademark. ECOPACK specifications are available at: www.st.com

Table 4. TO-264 Mechanical Data

DIM.	mm.			inch		
	MIN.	TYP.	MAX.	MIN.	TYP.	MAX.
A	4.80		5.20	0.189		0.205
D	2.50		3.10	0.098		0.122
E	0.50	0.60	0.85	0.020	0.24	0.033
F	0.90	1.00	1.25	0.036	0.039	0.049
G	10.30		11.50	0.406		0.453
G1		5.45			0.215	
H	19.80		20.20	0.780		0.795
L3	25.80		26.20	1.016		1.031
L5	5.80		6.20	0.228		0.244
L7	19.50		20.50	0.768		0.807
N	2.30		2.70	0.091		0.106
R	4.7		5.10	0.185		0.201
DIA	3.10		3.50	0.122		0.138

Figure 15. TO-264 Drawing

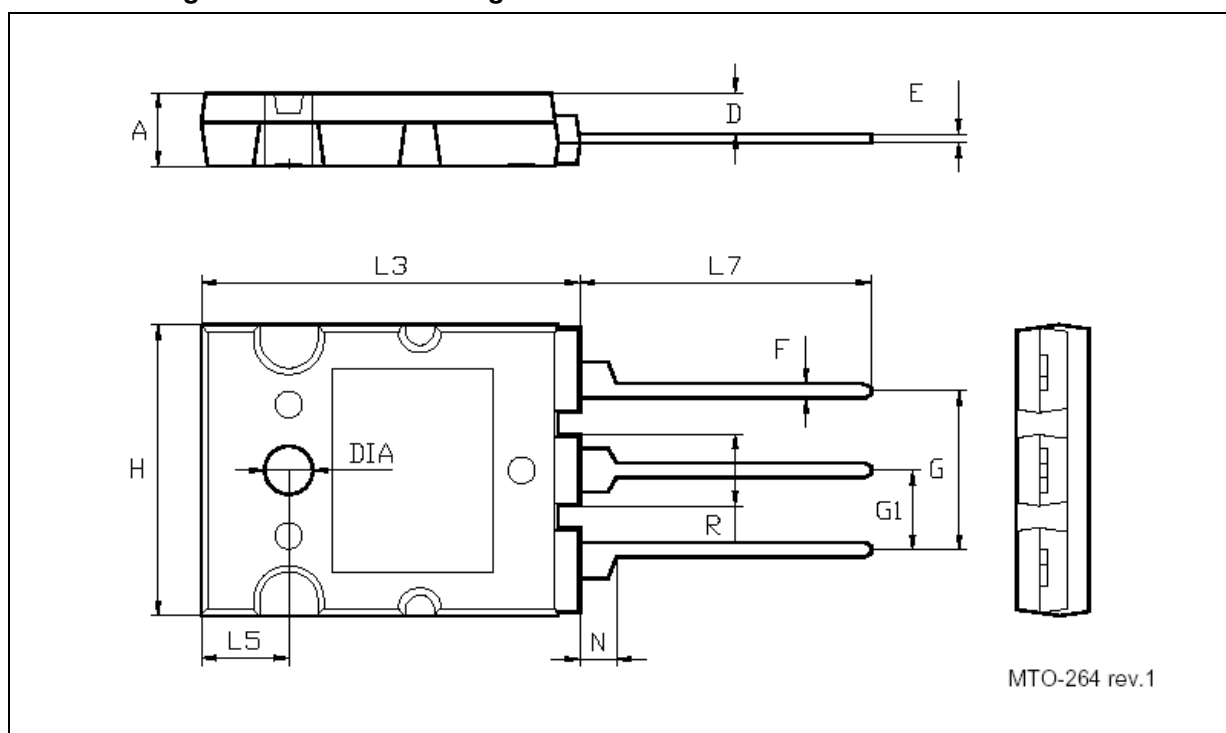

5 Revision history

Table 5. Revision history

Date	Revision	Changes
12-Oct-2006	1	Initial release.
17-Oct-2005	2	Final document
23-Feb-2007	3	The document has been reformatted

Please Read Carefully:

Information in this document is provided solely in connection with ST products. STMicroelectronics NV and its subsidiaries ("ST") reserve the right to make changes, corrections, modifications or improvements, to this document, and the products and services described herein at any time, without notice.

All ST products are sold pursuant to ST's terms and conditions of sale.

Purchasers are solely responsible for the choice, selection and use of the ST products and services described herein, and ST assumes no liability whatsoever relating to the choice, selection or use of the ST products and services described herein.

No license, express or implied, by estoppel or otherwise, to any intellectual property rights is granted under this document. If any part of this document refers to any third party products or services it shall not be deemed a license grant by ST for the use of such third party products or services, or any intellectual property contained therein or considered as a warranty covering the use in any manner whatsoever of such third party products or services or any intellectual property contained therein.

UNLESS OTHERWISE SET FORTH IN ST'S TERMS AND CONDITIONS OF SALE ST DISCLAIMS ANY EXPRESS OR IMPLIED WARRANTY WITH RESPECT TO THE USE AND/OR SALE OF ST PRODUCTS INCLUDING WITHOUT LIMITATION IMPLIED WARRANTIES OF MERCHANTABILITY, FITNESS FOR A PARTICULAR PURPOSE (AND THEIR EQUIVALENTS UNDER THE LAWS OF ANY JURISDICTION), OR INFRINGEMENT OF ANY PATENT, COPYRIGHT OR OTHER INTELLECTUAL PROPERTY RIGHT.

UNLESS EXPRESSLY APPROVED IN WRITING BY AN AUTHORIZED ST REPRESENTATIVE, ST PRODUCTS ARE NOT RECOMMENDED, AUTHORIZED OR WARRANTED FOR USE IN MILITARY, AIR CRAFT, SPACE, LIFE SAVING, OR LIFE SUSTAINING APPLICATIONS, NOR IN PRODUCTS OR SYSTEMS WHERE FAILURE OR MALFUNCTION MAY RESULT IN PERSONAL INJURY, DEATH, OR SEVERE PROPERTY OR ENVIRONMENTAL DAMAGE. ST PRODUCTS WHICH ARE NOT SPECIFIED AS "AUTOMOTIVE GRADE" MAY ONLY BE USED IN AUTOMOTIVE APPLICATIONS AT USER'S OWN RISK.

Resale of ST products with provisions different from the statements and/or technical features set forth in this document shall immediately void any warranty granted by ST for the ST product or service described herein and shall not create or extend in any manner whatsoever, any liability of ST.

ST and the ST logo are trademarks or registered trademarks of ST in various countries.

Information in this document supersedes and replaces all information previously supplied.

The ST logo is a registered trademark of STMicroelectronics. All other names are the property of their respective owners.

© 2007 STMicroelectronics - All rights reserved

STMicroelectronics group of companies

Australia - Belgium - Brazil - Canada - China - Czech Republic - Finland - France - Germany - Hong Kong - India - Israel - Italy - Japan - Malaysia - Malta - Morocco - Singapore - Spain - Sweden - Switzerland - United Kingdom - United States of America

www.st.com