



ELECTRONICS, INC.
 44 FARRAND STREET
 BLOOMFIELD, NJ 07003
 (973) 748-5089
<http://www.nteinc.com>



NTE2547 (NPN) & NTE2548 (PNP) Silicon Complementary Transistors Darlington Driver TO220 Full Pack

Features:

- High DC Current Gain
- High Current Capacity and Wide ASO
- Low Saturation Voltage

Applications:

- Motor Drivers
- Printer Hammer Drivers
- Relay Drivers
- Voltage Regulator Control

Absolute Maximum Ratings: ($T_A = +25^\circ\text{C}$ unless otherwise specified)

Collector to Base Voltage, V_{CB0}	110V
Collector to Emitter Voltage, V_{CEO}	100V
Emitter to Base Voltage, V_{EBO}	6V
Collector Current, I_C	
Continuous	8A
Peak	12A
Collector Dissipation, P_C	
$T_A = +25^\circ\text{C}$	2.0W
$T_C = +25^\circ\text{C}$	
NTE2547	30W
NTE2548	20W
Operating Junction Temperature, T_J	+150°C
Storage Temperature Range, T_{stg}	-55° to +150°C

Electrical Characteristics: ($T_A = +25^\circ\text{C}$ unless otherwise specified)

Parameter	Symbol	Test Conditions	Min	Typ	Max	Unit
Collector Cutoff Current	I_{CB0}	$V_{CB} = 80V, I_E = 0$	-	-	0.1	mA
Emitter Cutoff Current	I_{EBO}	$V_{EB} = 5V, I_C = 0$	-	-	3.0	mA
DC Current Gain	h_{FE}	$V_{CE} = 3V, I_C = 4A$	1500	4000		
Gain Bandwidth Product	f_T	$V_{CE} = 5V, I_C = 4A$	-	20	-	MHz

Electrical Characteristics (Cont'd): ($T_A = +25^\circ\text{C}$ unless otherwise specified)

Parameter	Symbol	Test Conditions	Min	Typ	Max	Unit
Collector to Emitter Saturation Voltage NTE2547	$V_{CE(sat)}$	$I_C = 4A, I_B = 8mA$	-	0.9	1.5	V
NTE2548			-	1.0	1.5	V
Base to Emitter Saturation Voltage	$V_{BE(sat)}$	$I_C = 4A, I_B = 8mA$	-	-	2.0	V
Collector-Base Breakdown Voltage	$V_{(BR)CBO}$	$I_C = 5mA, I_E = 0$	110	-	-	V
Collector-Emitter Breakdown Voltage	$V_{(BR)CEO}$	$I_C = 50mA, R_{BE} = \infty$	100	-	-	V
Turn-On Time NTE2547	t_{on}	$I_C = 4A, I_{B1} = 500mA,$ $I_{B2} = -500mA,$ Pulse Width = $50\mu s,$ Duty Cycle $\leq 1\%$, Note 1	-	0.6	-	μs
NTE2548			-	0.7	-	μs
Storage Time NTE2547	t_{stg}		-	4.8	-	μs
NTE2548			-	1.4	-	μs
Fall Time NTE2547	t_f		-	1.6	-	μs
NTE2548			-	1.5	-	μs

Note 1. For NTE2548 (PNP), the polarity is reversed.

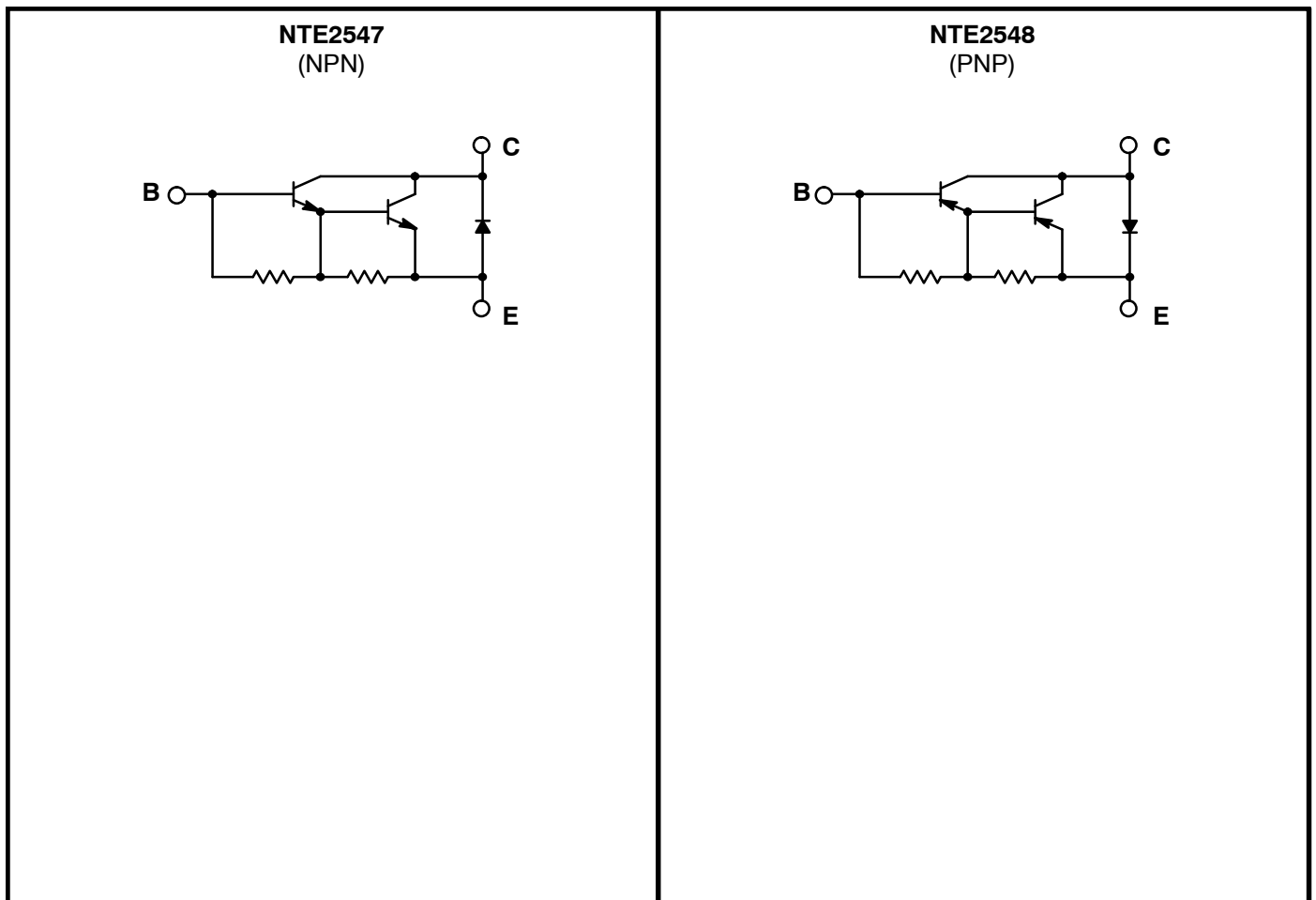

NTE2547

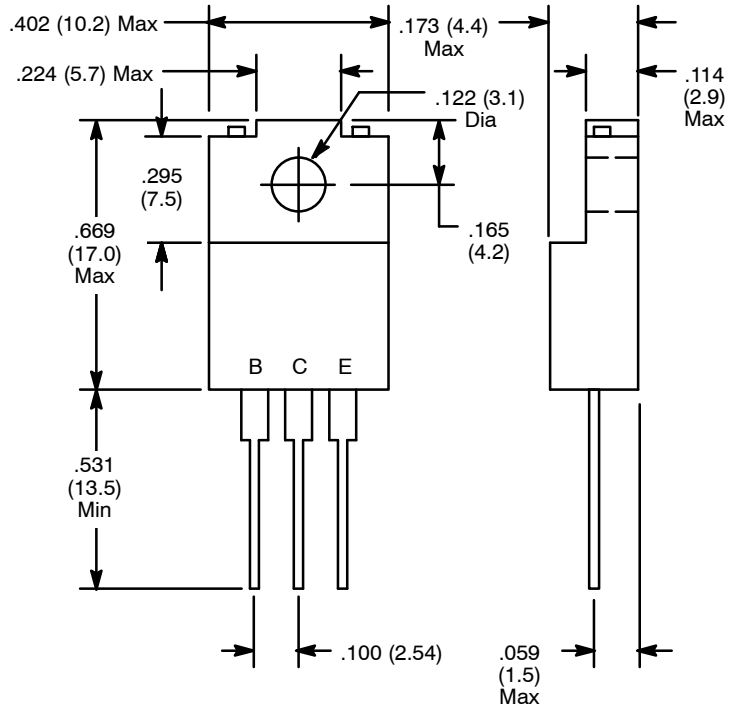

NOTE: Tab is isolated

NTE2548

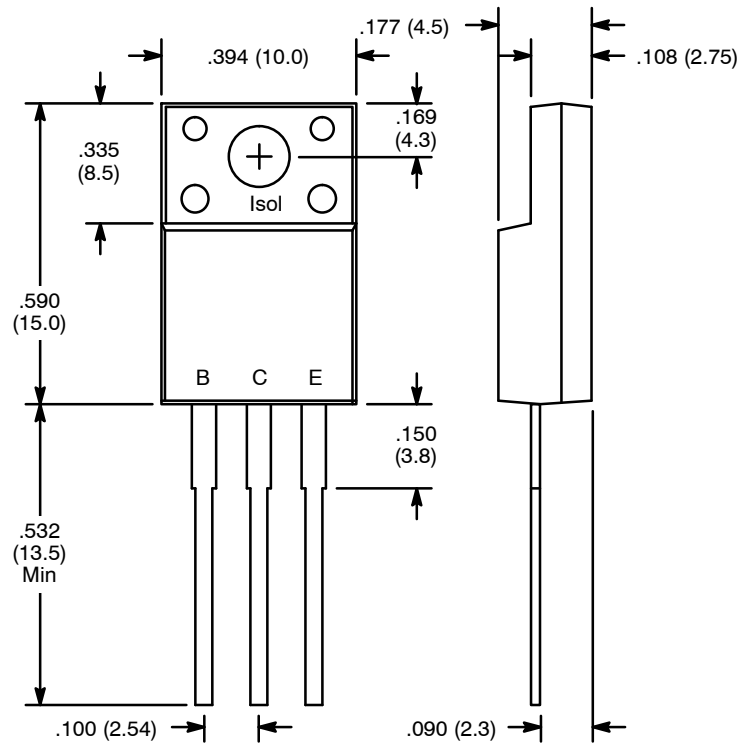

NOTE: Tab is isolated