

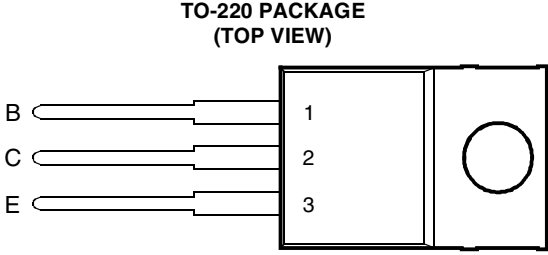

- 80 W at 25°C Case Temperature
- 7 A Continuous Collector Current
- 10 A Peak Collector Current
- Maximum $V_{CE(sat)}$ of 2 V at $I_C = 5$ A
- $I_{CEX(sus)}$ 7 A at rated $V_{(BR)CEO}$



Pin 2 is in electrical contact with the mounting base.

MDTRACA

absolute maximum ratings at 25°C case temperature (unless otherwise noted)

RATING		SYMBOL	VALUE	UNIT
Collector-base voltage ($I_E = 0$)	TIP150	V_{CBO}	300	V
	TIP151		350	
	TIP152		400	
Collector-emitter voltage ($I_B = 0$)	TIP150	V_{CEO}	300	V
	TIP151		350	
	TIP152		400	
Emitter-base voltage		V_{EBO}	8	V
Continuous collector current		I_C	7	A
Peak collector current (see Note 1)		I_{CM}	10	A
Continuous base current		I_B	1.5	A
Continuous device dissipation at (or below) 25°C case temperature (see Note 2)		P_{tot}	80	W
Continuous device dissipation at (or below) 25°C free air temperature (see Note 3)		P_{tot}	2	W
Operating junction temperature range		T_j	-65 to +150	°C
Storage temperature range		T_{stg}	-65 to +150	°C
Lead temperature 3.2 mm from case for 10 seconds		T_L	260	°C

- NOTES: 1. This value applies for $t_p \leq 5$ ms, duty cycle $\leq 10\%$.
 2. Derate linearly to 150°C case temperature at the rate of 0.64 W/°C.
 3. Derate linearly to 150°C free air temperature at the rate of 16 mW/°C.

PRODUCT INFORMATION

electrical characteristics at 25°C case temperature

PARAMETER	TEST CONDITIONS			MIN	TYP	MAX	UNIT
$V_{(BR)CBO}$ Collector-base breakdown voltage	$I_C = 1 \text{ mA}$	$I_E = 0$	TIP150 TIP151 TIP152	300 350 400			V
$V_{(BR)CEO}$ Collector-emitter breakdown voltage	$I_C = 10 \text{ mA}$ (see Note 4)	$I_B = 0$	TIP150 TIP151 TIP152	300 350 400			V
I_{CEO} Collector-emitter cut-off current	$V_{CE} = 300 \text{ V}$ $V_{CE} = 350 \text{ V}$ $V_{CE} = 400 \text{ V}$	$I_B = 0$ $I_B = 0$ $I_B = 0$	TIP150 TIP151 TIP152			250 250 250	μA
$I_{CEX(sus)}$ Collector-emitter sustaining current	$V_{CLAMP} = V_{(BR)CEO}$			7			A
I_{EBO} Emitter cut-off current	$V_{EB} = 8 \text{ V}$	$I_C = 0$				15	mA
h_{FE} Forward current transfer ratio	$V_{CE} = 5 \text{ V}$ $V_{CE} = 5 \text{ V}$ $V_{CE} = 5 \text{ V}$	$I_C = 2.5 \text{ A}$ $I_C = 5 \text{ A}$ $I_C = 7 \text{ A}$	(see Notes 4 and 5)	150 50 15			
$V_{CE(sat)}$ Collector-emitter saturation voltage	$I_B = 10 \text{ mA}$ $I_B = 100 \text{ mA}$ $I_B = 250 \text{ mA}$	$I_C = 1 \text{ A}$ $I_C = 2 \text{ A}$ $I_C = 5 \text{ A}$	(see Notes 4 and 5)			1.5 1.5 2	V
$V_{BE(sat)}$ Base-emitter saturation voltage	$I_B = 100 \text{ mA}$ $I_B = 250 \text{ mA}$	$I_C = 2 \text{ A}$ $I_C = 5 \text{ A}$	(see Notes 4 and 5)			2.2 2.3	V
V_{EC} Parallel diode forward voltage	$I_E = 7 \text{ A}$	$I_B = 0$	(see Notes 4 and 5)			3.5	V
h_{fe} Small signal forward current transfer ratio	$V_{CE} = 5 \text{ V}$	$I_C = 0.5 \text{ A}$	$f = 1 \text{ kHz}$	200			
$ h_{fe} $ Small signal forward current transfer ratio	$V_{CE} = 5 \text{ V}$	$I_C = 0.5 \text{ A}$	$f = 1 \text{ MHz}$	10			
C_{ob} Output capacitance	$V_{CB} = 10 \text{ V}$	$I_E = 0$	$f = 1 \text{ MHz}$			100	pF

NOTES: 4. These parameters must be measured using pulse techniques, $t_p = 300 \mu\text{s}$, duty cycle $\leq 2\%$.

5. These parameters must be measured using voltage-sensing contacts, separate from the current carrying contacts.

thermal characteristics

PARAMETER	MIN	TYP	MAX	UNIT
$R_{\theta JC}$ Junction to case thermal resistance			1.56	$^{\circ}\text{C}/\text{W}$
$R_{\theta JA}$ Junction to free air thermal resistance			62.5	$^{\circ}\text{C}/\text{W}$
$C_{\theta C}$ Thermal capacitance of case		0.9		$\text{J}/^{\circ}\text{C}$

inductive-load-switching characteristics at 25°C case temperature

PARAMETER	TEST CONDITIONS †			MIN	TYP	MAX	UNIT
t_{sv} Voltage storage time	$I_C = 5 \text{ A}$ $V_{(clamp)} = V_{(BR)CEO}$	$I_{B(on)} = 250 \text{ mA}$	$R_{BE} = 47 \Omega$		3.9		μs
t_{si} Current storage time					4.7		μs
t_{rv} Voltage transition time					1.2		μs
t_{ti} Current transition time					1.2		μs
t_{xo} Cross-over time					2.0		μs

† Voltage and current values shown are nominal; exact values vary slightly with transistor parameters.

PRODUCT INFORMATION

PARAMETER MEASUREMENT INFORMATION

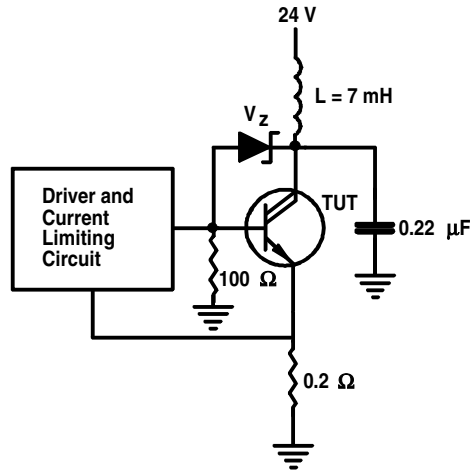

Figure 1. Functional Test Circuit

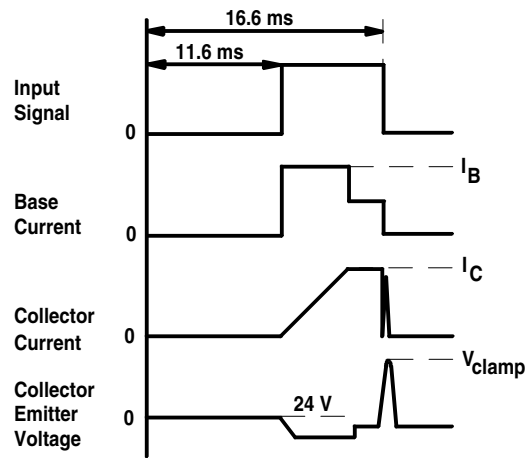

Figure 2. Functional Test Waveforms

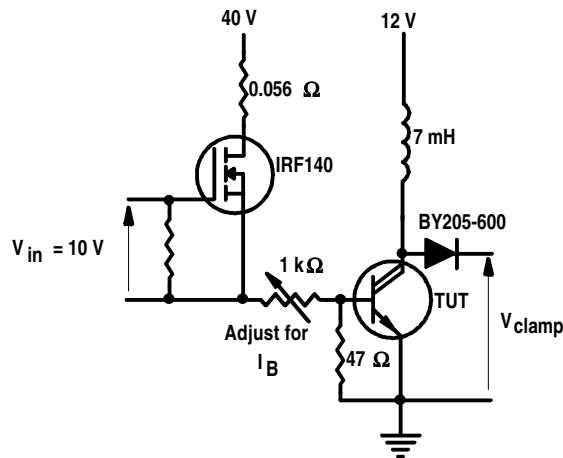

Figure 3. Switching Test Circuit

PRODUCT INFORMATION

TYPICAL CHARACTERISTICS

**TYPICAL DC CURRENT GAIN
VS
COLLECTOR CURRENT**

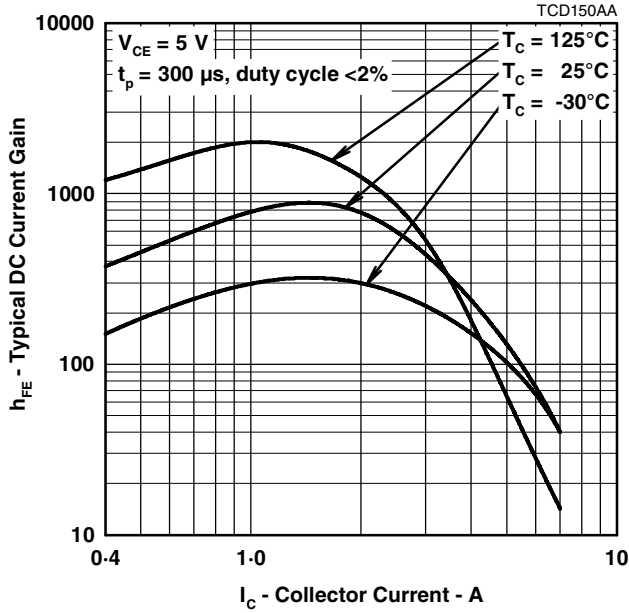

Figure 4.

**COLLECTOR-EMITTER SATURATION VOLTAGE
VS
COLLECTOR CURRENT**

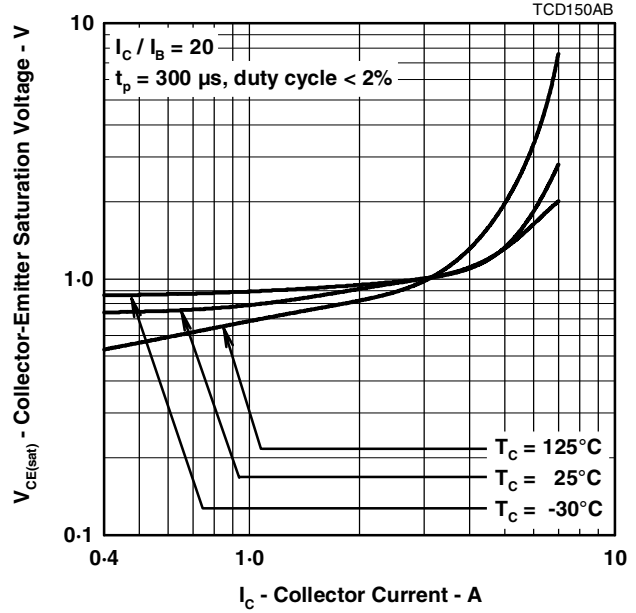

Figure 5.

**BASE-EMITTER SATURATION VOLTAGE
VS
COLLECTOR CURRENT**

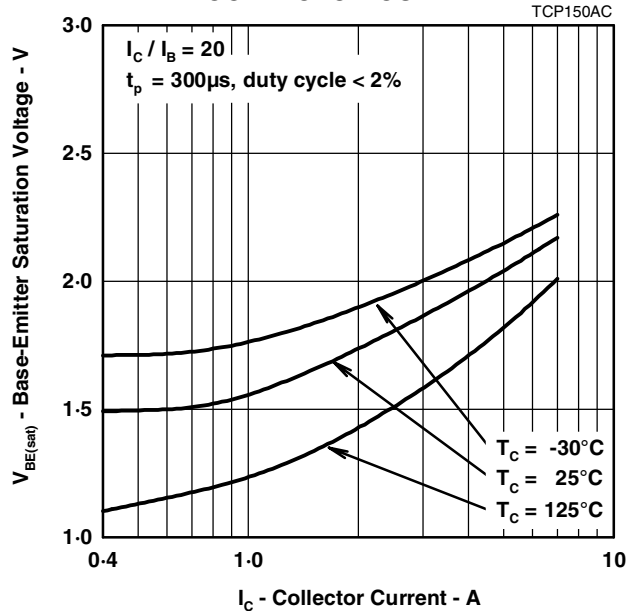

Figure 6.

**COLLECTOR CUT-OFF CURRENT
VS
CASE TEMPERATURE**

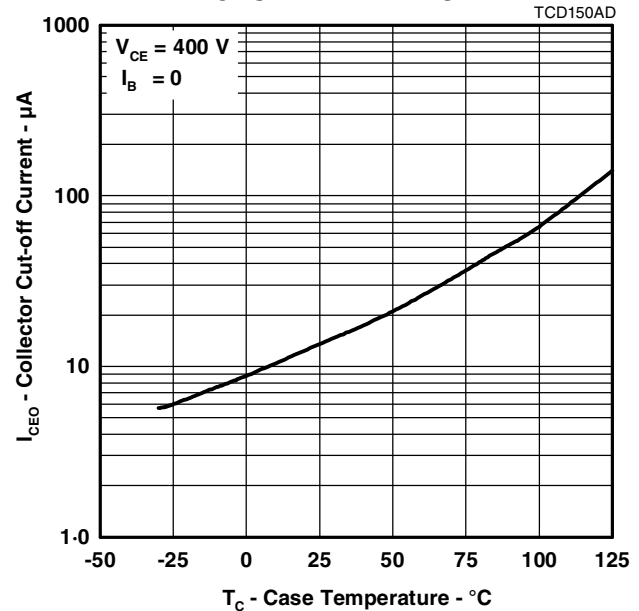

Figure 7.

PRODUCT INFORMATION

MAXIMUM SAFE OPERATING REGIONS

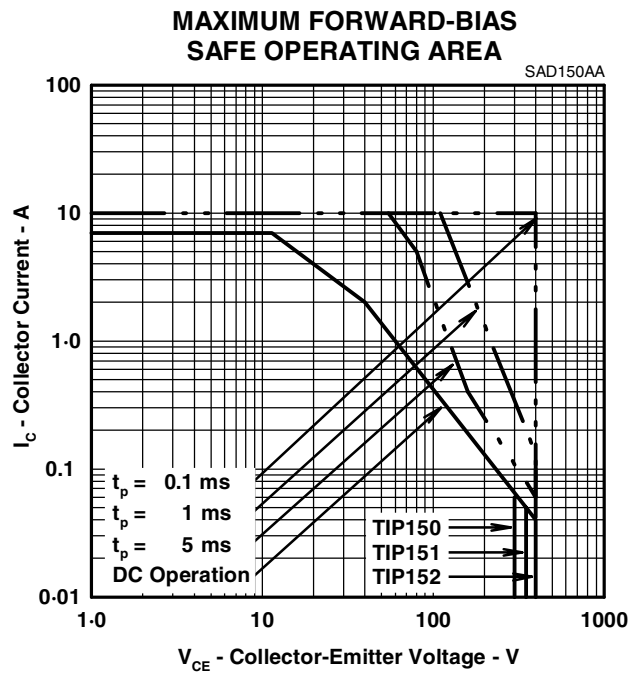

Figure 8.

THERMAL INFORMATION

**MAXIMUM POWER DISSIPATION
vs
CASE TEMPERATURE**

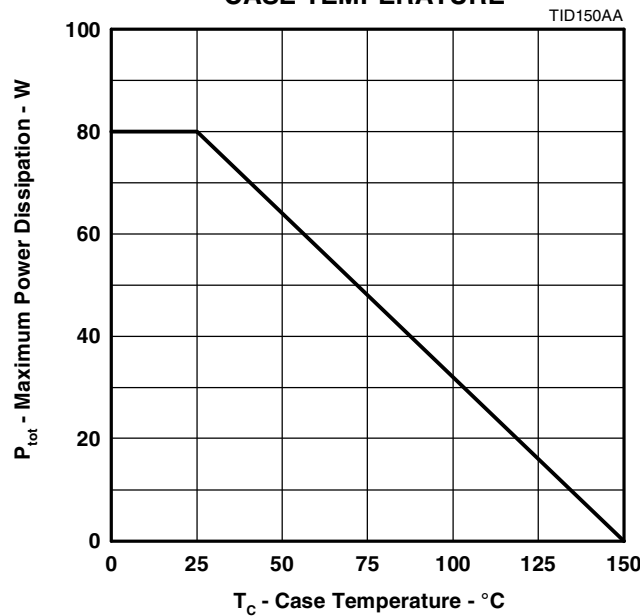

Figure 9.

PRODUCT INFORMATION