

IRGP20B120U-E

INSULATED GATE BIPOLAR TRANSISTOR

Features

- UltraFast Non Punch Through (NPT) Technology
- 10 μ s Short Circuit capability
- Square RBSOA
- Positive $V_{CE(on)}$ Temperature Coefficient
- Extended lead TO-247 package

Benefits

- Benchmark efficiency above 20KHz
- Optimized for Welding, UPS, and Induction Heating applications
- Rugged with UltraFast performance
- Low EMI
- Significantly Less Snubber required
- Excellent Current sharing in Parallel operation
- Longer leads for easier mounting

UltraFast IGBT

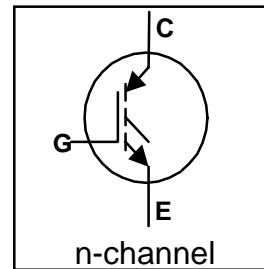

$V_{CES} = 1200V$
$V_{CE(on) typ.} = 3.05V$
$V_{GE} = 15V, I_C = 20A, 25^\circ C$

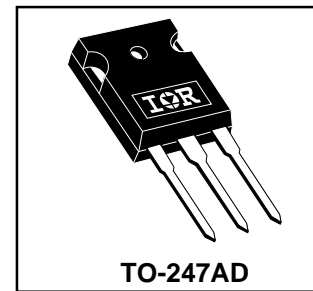

Absolute Maximum Ratings

	Parameter	Max.	Units
V_{CES}	Collector-to-Emitter Breakdown Voltage	1200	V
$I_C @ T_C = 25^\circ C$	Continuous Collector Current (Fig.1)	40	A
$I_C @ T_C = 100^\circ C$	Continuous Collector Current (Fig.1)	20	
I_{CM}	Pulsed Collector Current (Fig.3, Fig. CT.5)	120	
I_{LM}	Clamped Inductive Load Current(Fig.4, Fig. CT.2)	120	
V_{GE}	Gate-to-Emitter Voltage	± 20	V
$E_{AS} @ T_C = 25^\circ C$	Avalanche Energy, single pulse $I_C = 25A, V_{CC} = 50V, R_{GE} = 25ohm$ $L = 200\mu H$ (Fig. CT.6)	65	mJ
$P_D @ T_C = 25^\circ C$	Maximum Power Dissipation (Fig.2)	300	W
$P_D @ T_C = 100^\circ C$	Maximum Power Dissipation (Fig.2)	120	
T_J T_{STG}	Operating Junction and Storage Temperature Range	-55 to + 150	$^\circ C$
	Soldering Temperature, for 10 seconds	300, (0.063 in. (1.6mm) from case)	
	Mounting torque, 6-32 or M3 screw.	10 lbf•in (1.1N•m)	

Thermal Resistance

	Parameter	Min.	Typ.	Max.	Units
$R_{\theta JC}$	Junction-to-Case - IGBT	—	—	0.42	$^\circ C/W$
$R_{\theta CS}$	Case-to-Sink, flat, greased surface	—	0.24	—	
$R_{\theta JA}$	Junction-to-Ambient, typical socket mount	—	—	40	
Wt	Weight	—	6 (0.21)	—	g (oz)
$Z_{\theta JC}$	Transient Thermal Impedance Junction-to-Case (Fig.18)				

Electrical Characteristics @ T_J = 25°C (unless otherwise specified)

	Parameter	Min.	Typ.	Max.	Units	Conditions	Fig.
V _{(BR)CES}	Collector-to-Emitter Breakdown Voltage	1200			V	V _{GE} = 0V, I _c = 250 μA	
ΔV _{(BR)CES} / ΔT _J	Temperature Coeff. of Breakdown Voltage		+1.2		V/°C	V _{GE} = 0V, I _c = 1 mA (25 -125 °C)	
V _{CE(on)}	Collector-to-Emitter Saturation Voltage		3.05	3.45	V	I _c = 20A, V _{GE} = 15V	5, 6
			3.37	3.80		I _c = 25A, V _{GE} = 15V	7, 8
			4.23	4.85		I _c = 40A, V _{GE} = 15V	9
			3.89	4.50		I _c = 20A, V _{GE} = 15V, T _J = 125°C	10
			4.31	5.06		I _c = 25A, V _{GE} = 15V, T _J = 125°C	
V _{GE(th)}	Gate Threshold Voltage	4.0	5.0	6.0	V	V _{CE} = V _{GE} , I _c = 250 μA	8,9,10,11
ΔV _{GE(th)} / ΔT _J	Temperature Coeff. of Threshold Voltage		- 1.2		mV/°C	V _{CE} = V _{GE} , I _c = 1 mA (25 -125 °C)	
g _{fe}	Forward Transconductance	13.6	15.7	17.8	S	V _{CE} = 50V, I _c = 20A, PW=80μs	
I _{CES}	Zero Gate Voltage Collector Current			250	μA	V _{GE} = 0V, V _{CE} = 1200V	
			420	750		V _{GE} = 0V, V _{CE} = 1200V, T _J = 125°C	
			1482	2200		V _{GE} = 0V, V _{CE} = 1200V, T _J = 150°C	
I _{GES}	Gate-to-Emitter Leakage Current			±100	nA	V _{GE} = ±20V	

Switching Characteristics @ T_J = 25°C (unless otherwise specified)

	Parameter	Min.	Typ.	Max.	Units	Conditions	Fig.
Q _g	Total Gate charge (turn-on)		169	254	nC	I _c = 20A	17
Q _{ge}	Gate - Emitter Charge (turn-on)		24	36		V _{CC} = 600V	CT 1
Q _{gc}	Gate - Collector Charge (turn-on)		82	126		V _{GE} = 15V	
E _{on}	Turn-On Switching Loss *		850	1050	μJ	I _c = 20A, V _{CC} = 600V	CT 4
E _{off}	Turn-Off Switching Loss *		425	650		V _{GE} = 15V, R _g = 5Ω, L = 200μH	WF 1
E _{tot}	Total Switching Loss *		1275	1800		T _J = 25°C, Energy losses include tail and diode reverse recovery	WF 2
E _{on}	Turn-on Switching Loss *		1350	1550	μJ	I _c = 20A, V _{CC} = 600V	12, 14
E _{off}	Turn-off Switching Loss *		610	875		V _{GE} = 15V, R _g = 5Ω, L = 200μH	CT 4
E _{tot}	Total Switching Loss *		1960	2425		T _J = 125°C, Energy losses include tail and diode reverse recovery	WF 1 & 2
td(on)	Turn - on delay time		50	65	ns	I _c = 20A, V _{CC} = 600V	13, 15
tr	Rise time		20	30		V _{GE} = 15V, R _g = 5Ω, L = 200μH	CT 4
td(off)	Turn - off delay time		204	230		T _J = 125°C	WF 1
tf	Fall time		24	35			WF 2
C _{ies}	Input Capacitance		2200			pF	V _{GE} = 0V
C _{oes}	Output Capacitance		210		V _{CC} = 30V		
C _{res}	Reverse Transfer Capacitance		85		f = 1.0 MHz		
RBSOA	Reverse bias safe operating area	FULL SQUARE				T _J = 150°C, I _c = 120A V _{CC} = 1000V, V _p = 1200V R _g = 5Ω, V _{GE} = +15V to 0V	4 CT 2
SCSOA	Short Circuit Safe Operating Area	10	----	----	μs	T _J = 150°C V _{CC} = 900V, V _p = 1200V R _g = 5Ω, V _{GE} = +15V to 0V	CT 3 WF 3
Le	Internal Emitter Inductance		13		nH	Measured 5 mm from the package.	

* Used Diode HF40D120ACE

Fig.1 - Maximum DC Collector Current vs. Case Temperature

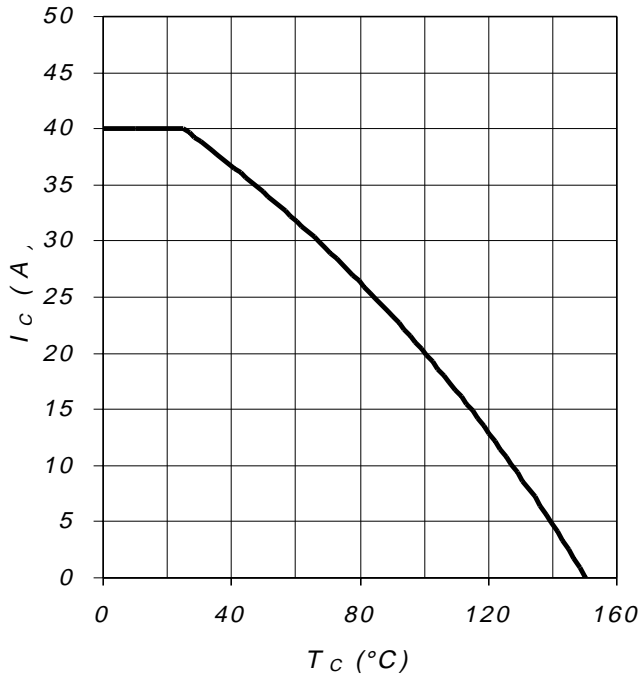

Fig.2 - Power Dissipation vs. Case Temperature

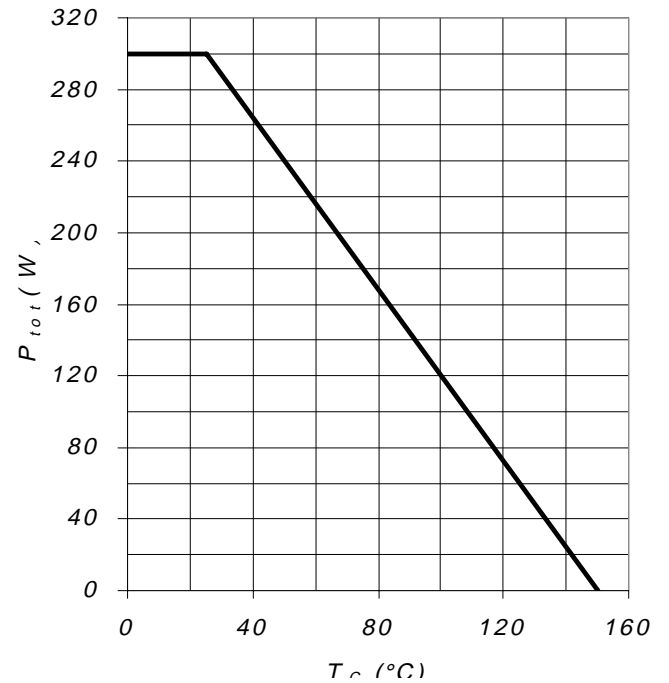

Fig.3 - Forward SOA
 $T_C=25^{\circ}C$; $T_j \leq 150^{\circ}C$

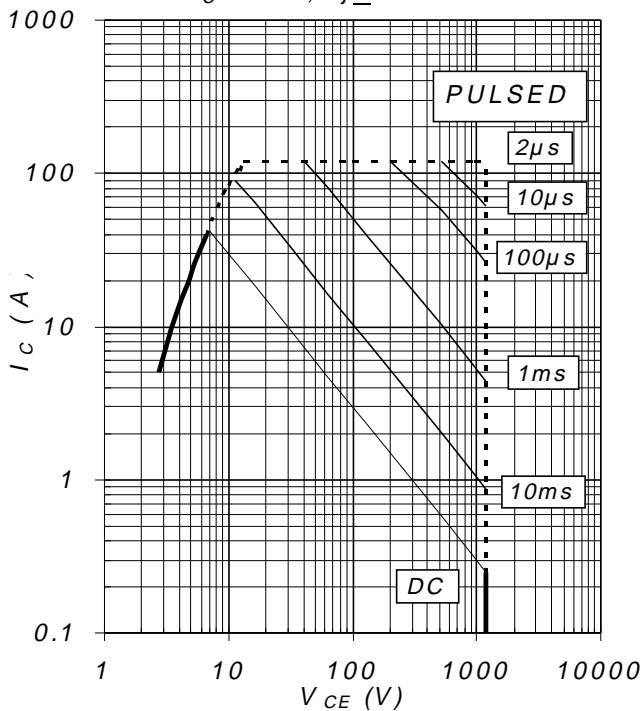

Fig.4 - Reverse Bias SOA
 $T_j = 150^{\circ}C$, $V_{GE} = 15V$

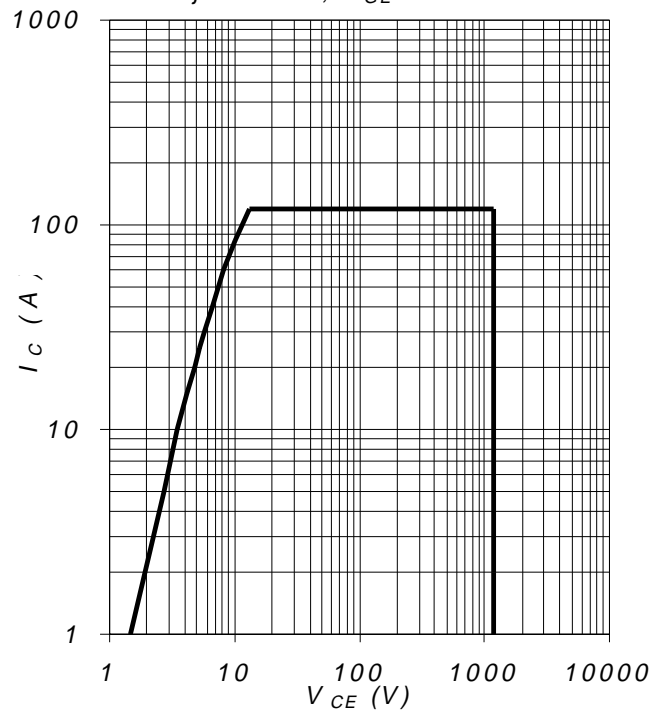

Fig.5 - Typical IGBT Output Characteristics

$T_j = -40^\circ\text{C}; t_p = 300\mu\text{s}$

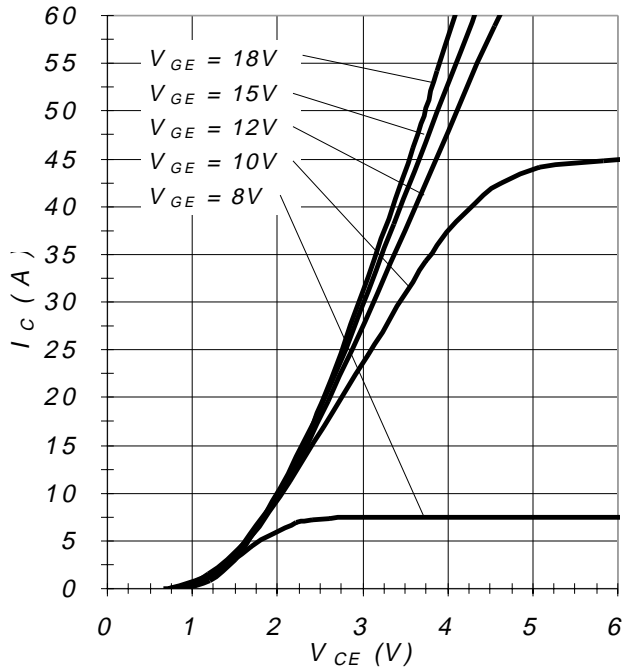

Fig.6 - Typical IGBT Output Characteristics

$T_j = 25^\circ\text{C}; t_p = 300\mu\text{s}$

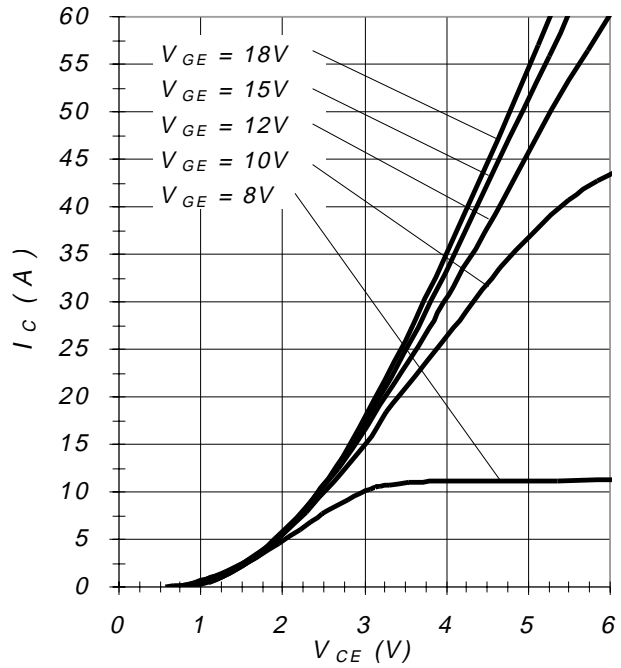

Fig.7 - Typical IGBT Output Characteristics

$T_j = 125^\circ\text{C}; t_p = 300\mu\text{s}$

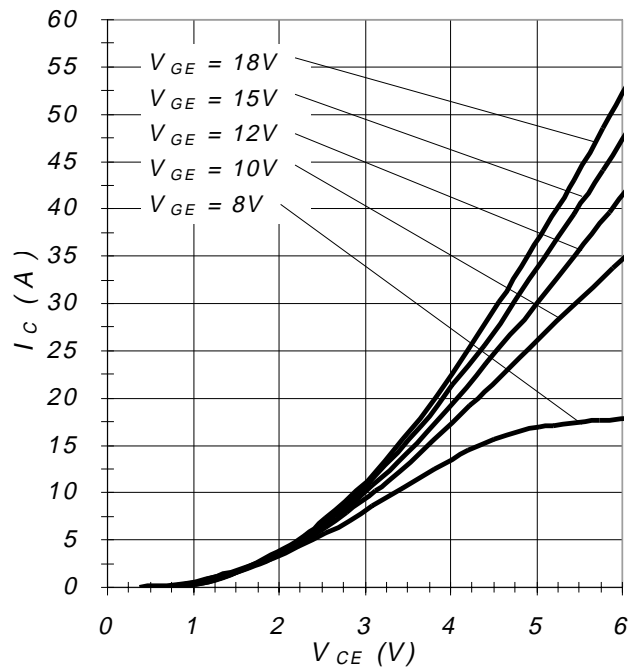

Fig. 8 - Typical V_{CE} vs V_{GE}
 $T_j = -40^\circ\text{C}$

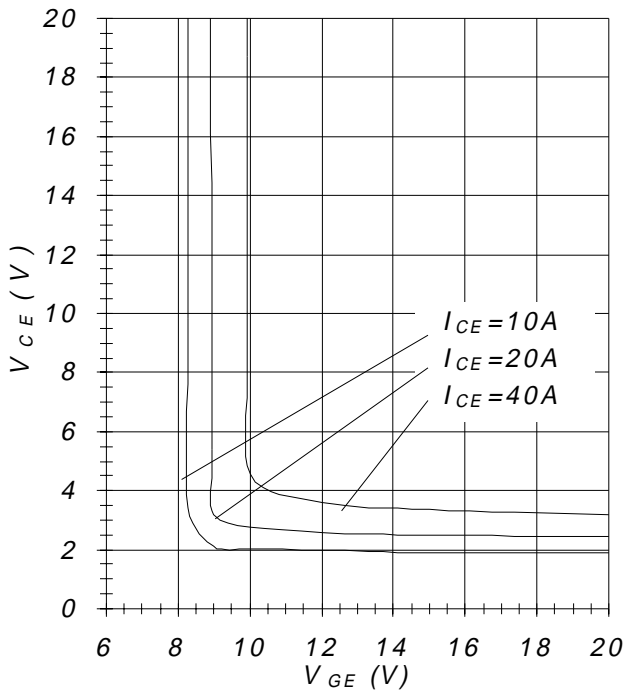

Fig. 9 - Typical V_{CE} vs V_{GE}
 $T_j = 25^\circ\text{C}$

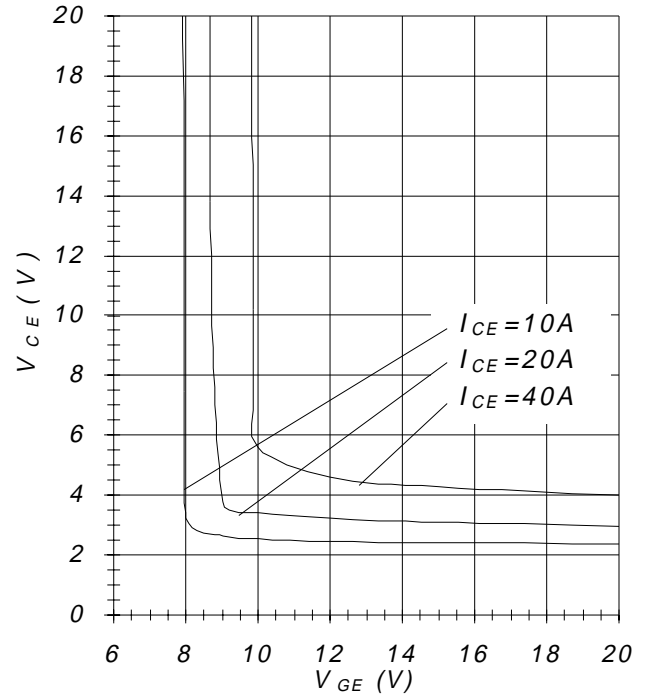

Fig. 10 - Typical V_{CE} vs V_{GE}
 $T_j = 125^\circ\text{C}$

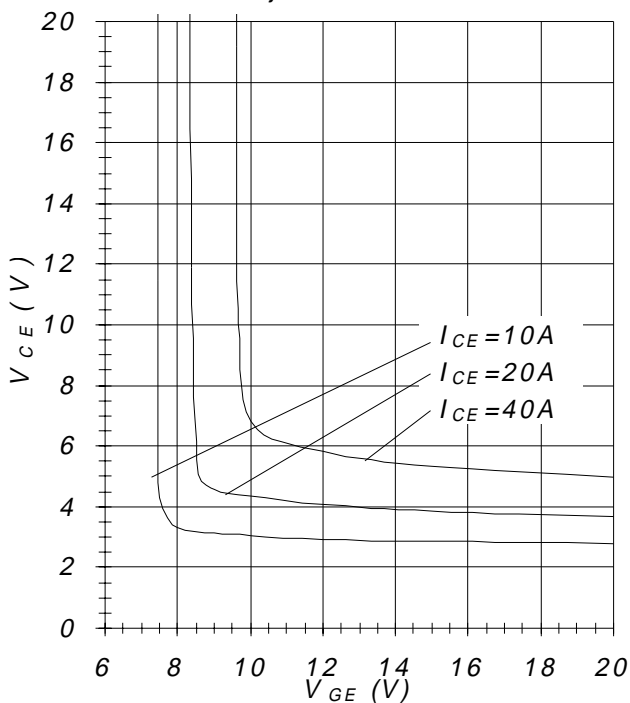

Fig. 11 - Typ. Transfer Characteristics
 $V_{CE} = 20\text{V}$; $t_p = 20\mu\text{s}$

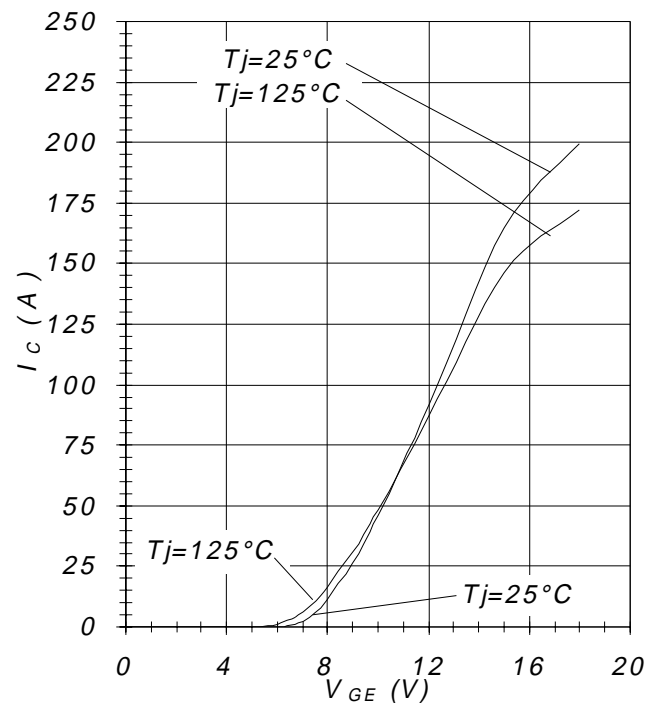

Fig.12 - Typical Energy Loss vs I_C
 $T_j=125^\circ\text{C}$; $L=200\mu\text{H}$; $V_{CE}=600\text{V}$;
 $R_g=22\ \Omega$; $V_{GE}=15\text{V}$

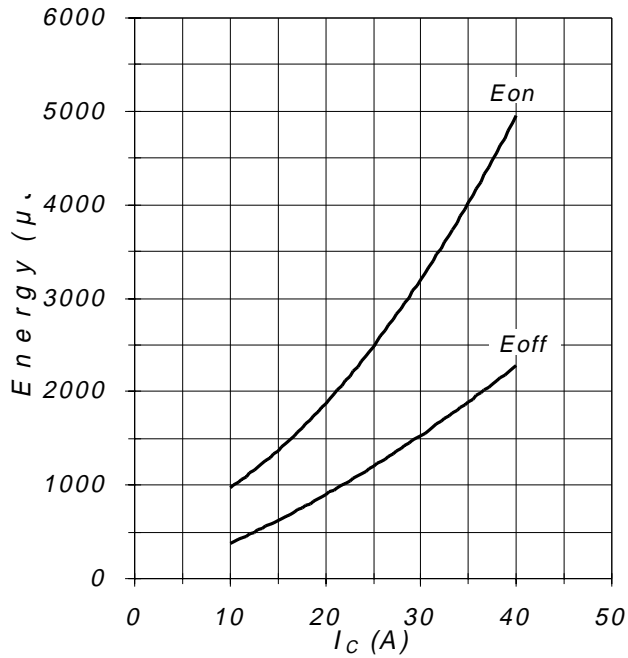

Fig.13 - Typical Switching Time vs I_C
 $T_j=125^\circ\text{C}$; $L=200\mu\text{H}$; $V_{CE}=600\text{V}$;
 $R_g=22\ \Omega$; $V_{GE}=15\text{V}$

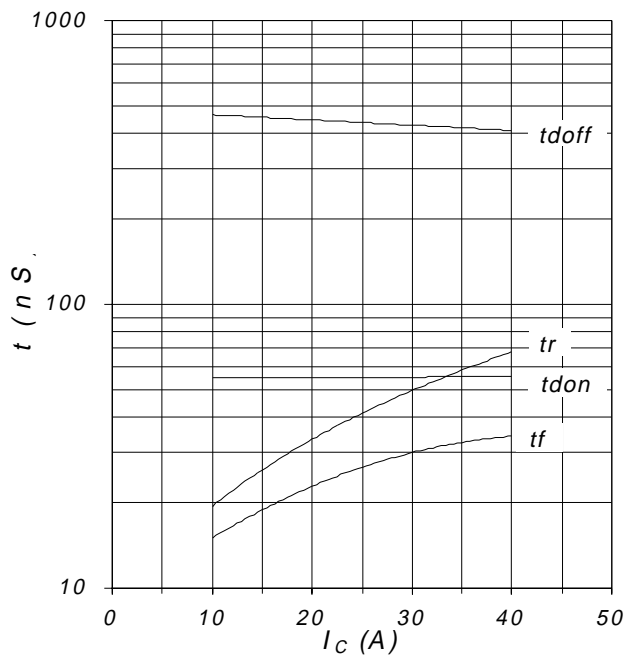

Fig.14 - Typical Energy Loss vs R_g
 $T_j=125^\circ\text{C}$; $L=200\mu\text{H}$; $V_{CE}=600\text{V}$;
 $I_{CE}=20\text{A}$; $V_{GE}=15\text{V}$

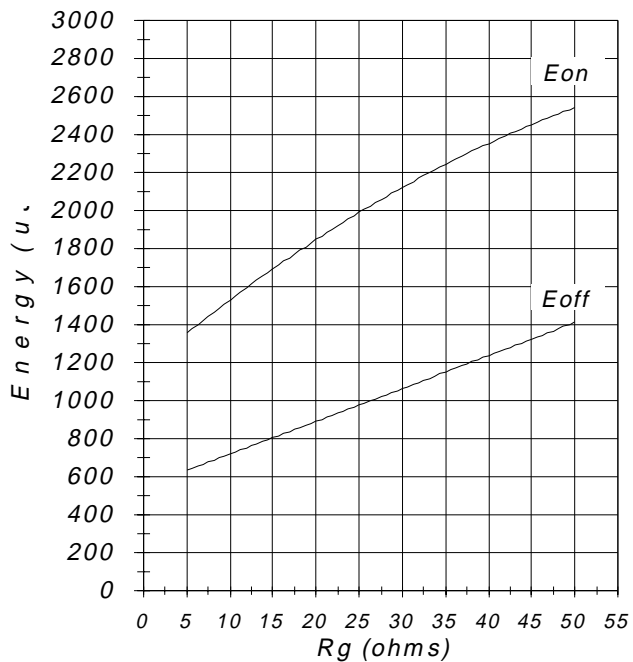

Fig.15 - Typical Switching Time vs R_g
 $T_j=125^\circ\text{C}$; $L=200\mu\text{H}$; $V_{CE}=600\text{V}$;
 $I_{CE}=20\text{A}$; $V_{GE}=15\text{V}$

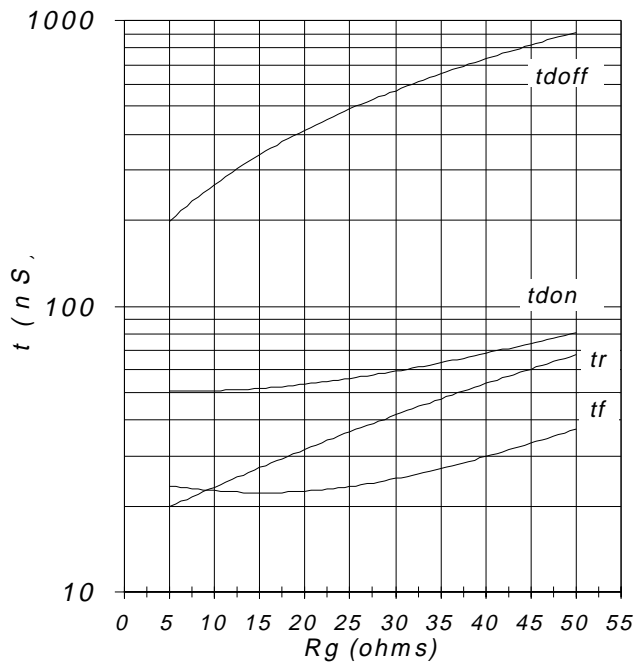

Fig. 16 - Typical Capacitance vs V_{CE}
 $V_{GE}=0V; f=1MHz$

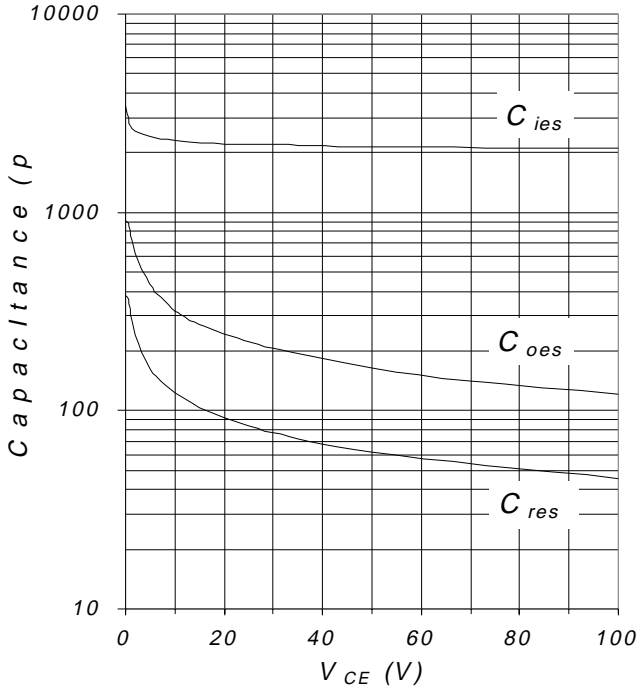

Fig. 17 - Typ. Gate Charge vs. V_{GE}
 $I_C=20A; L=600\mu H$

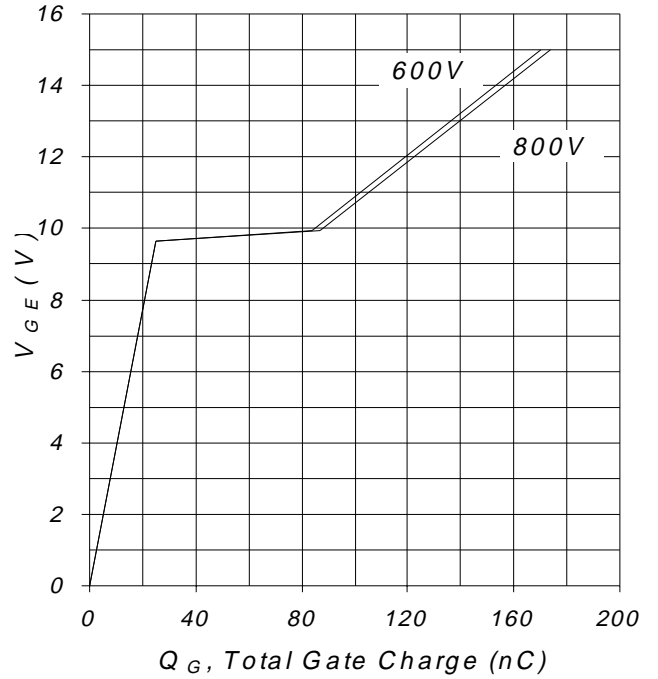

Fig. 18 - Normalized Transient Thermal Impedance, Junction-to-Case

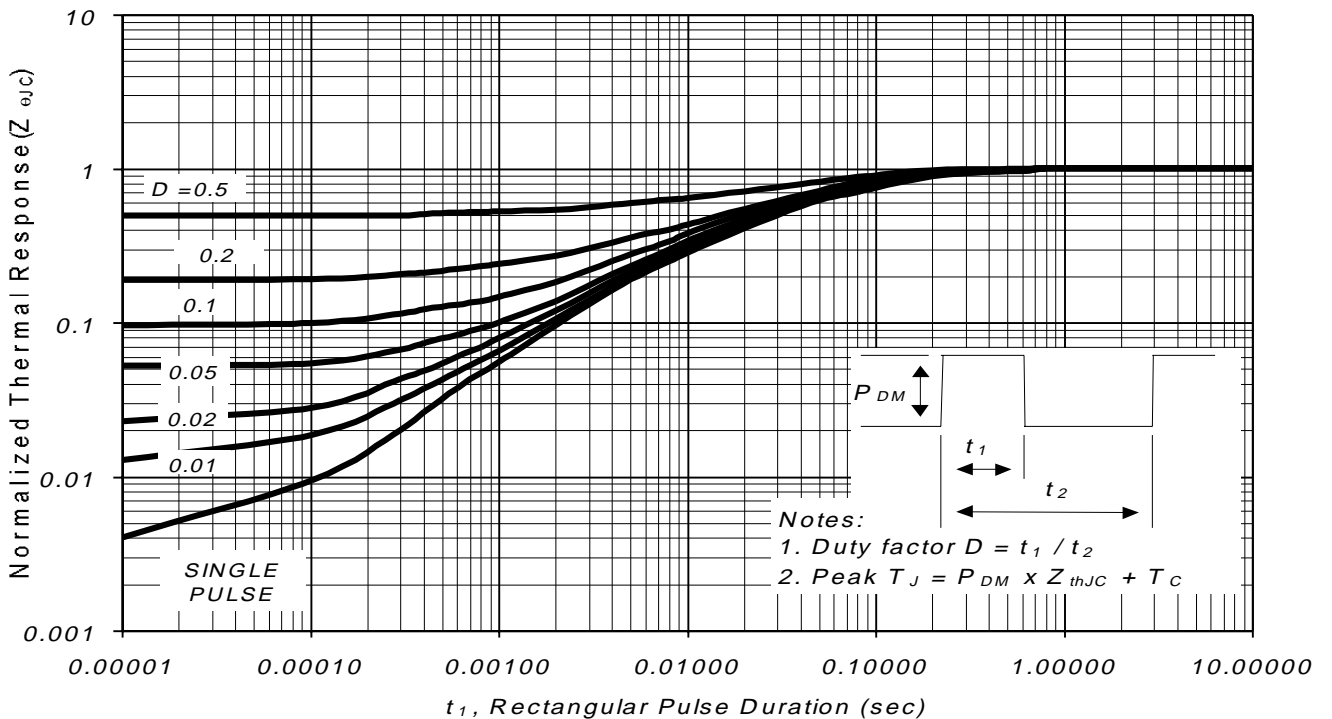

Fig. CT.1 - Gate Charge Circuit (turn-off)

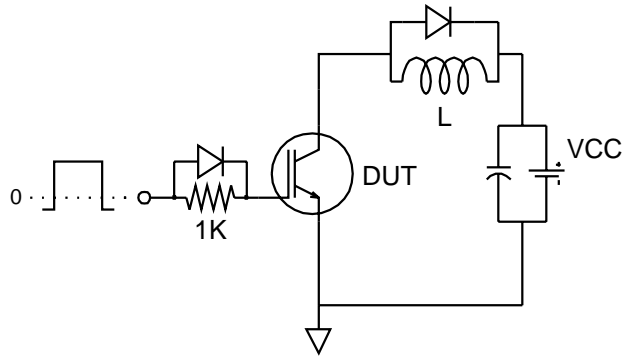

Fig. CT.2 - RBSOA Circuit

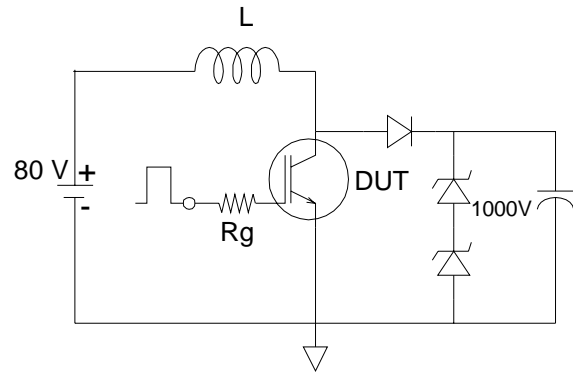

Fig. CT.3 - S.C. SOA Circuit

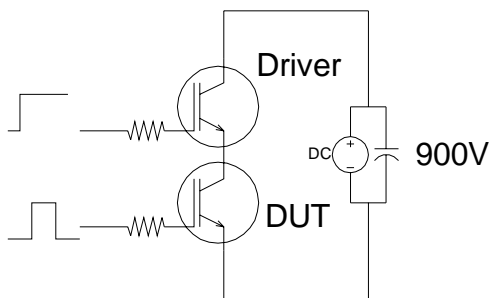

Fig. CT.4 - Switching Loss Circuit

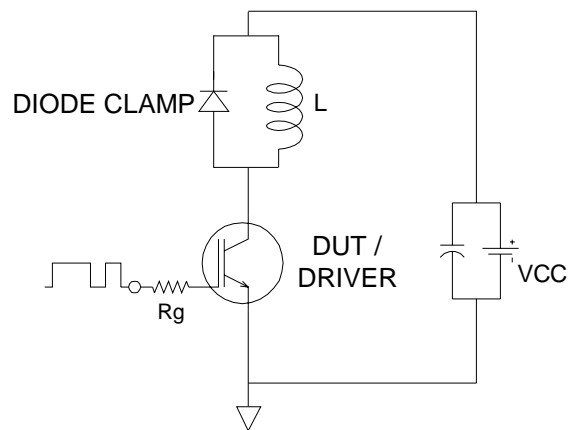

Fig. CT.5 - Resistive Load Circuit

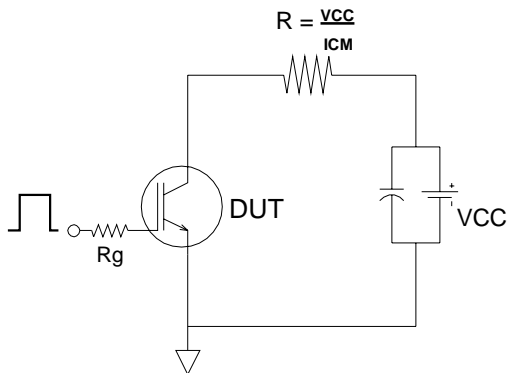

Fig. CT.6 - Unclamped Inductive Load Circuit

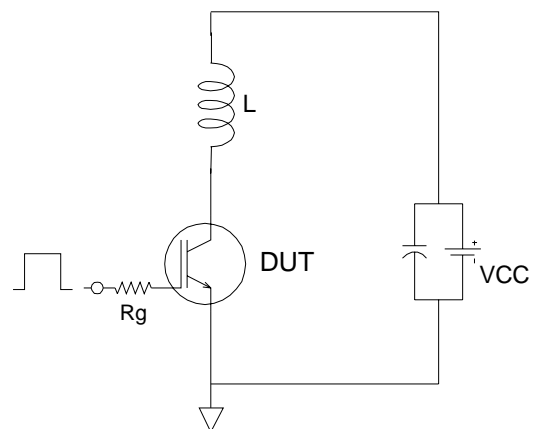

Fig. WF.1 - Typ. Turn-off Loss Waveform
@ $T_j=125^\circ\text{C}$ using Fig. CT.4

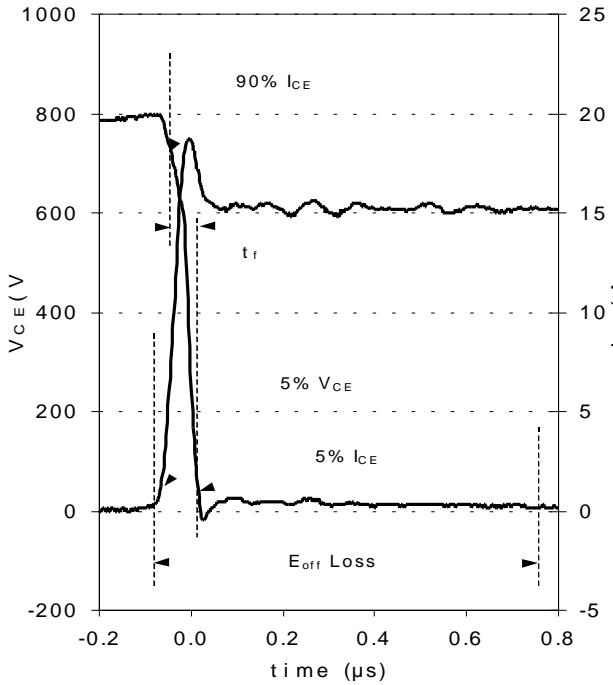

Fig. WF.2 - Typ. Turn-on Loss Waveform
@ $T_j=125^\circ\text{C}$ using Fig. CT.4

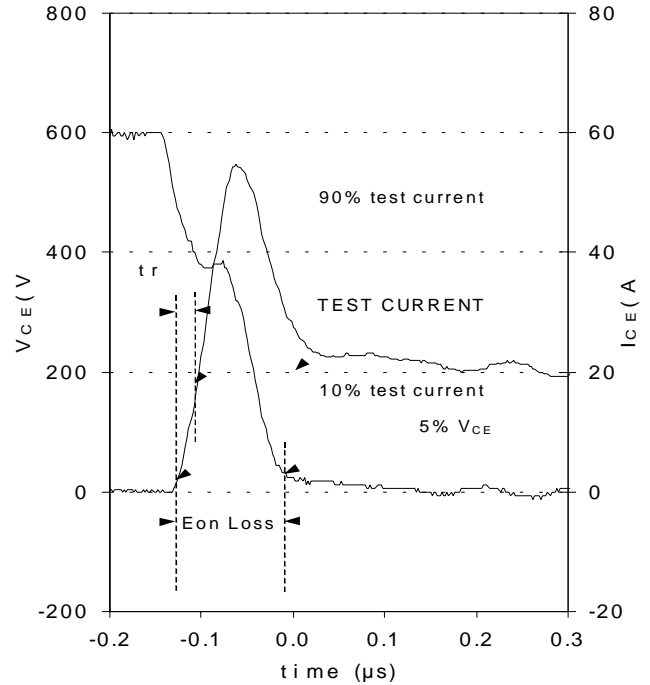
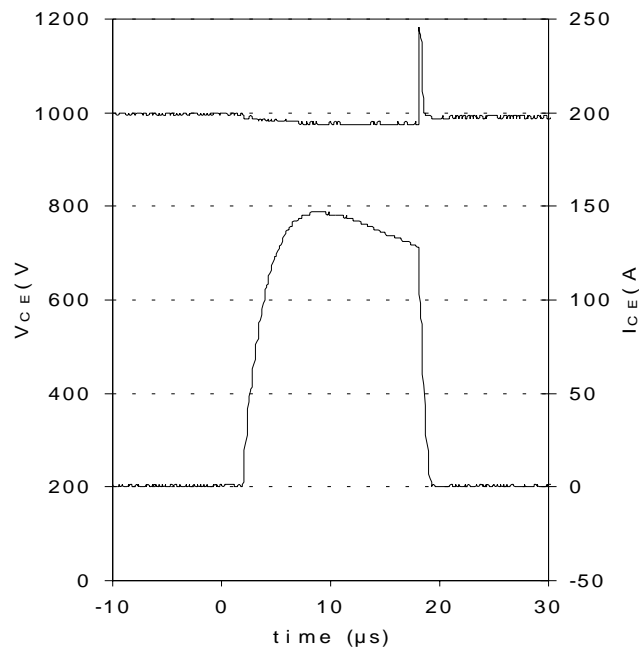
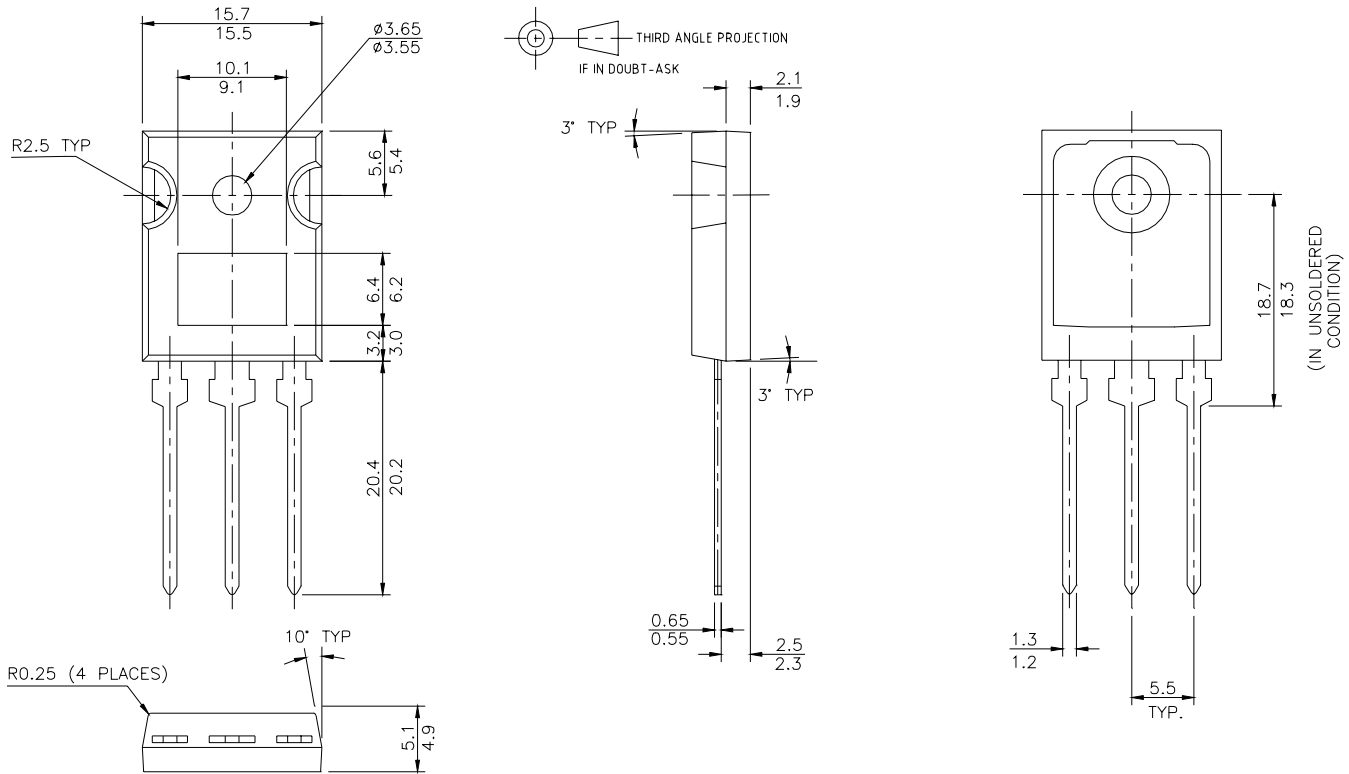

Fig. WF.3- Typ. S.C. Waveform
@ $T_C=150^\circ\text{C}$ using Fig. CT.3



IRGP20B120U-E

TO-247AD Case Outline and Dimensions



Data and specifications subject to change without notice.
This product has been designed and qualified for the industrial market.
Qualification Standards can be found on IR's Web site.

International
IR Rectifier

IR WORLD HEADQUARTERS: 233 Kansas St., El Segundo, California 90245, USA Tel: (310) 252-7105

TAC Fax: (310) 252-7903

Visit us at www.irf.com for sales contact information.03/01

www.irf.com

Note: For the most current drawings please refer to the IR website at:
<http://www.irf.com/package/>