

Thunderbolt IGBT®

The Thunderbolt IGBT® is a new generation of high voltage power IGBTs. Using Non-Punch Through Technology the Thunderbolt IGBT® offers superior ruggedness and ultrafast switching speed.

- Low Forward Voltage Drop
- Low Tail Current
- Avalanche Rated
- RoHS Compliant
- High Freq. Switching to 150KHz
- Ultra Low Leakage Current
- RBSOA and SCSOA Rated

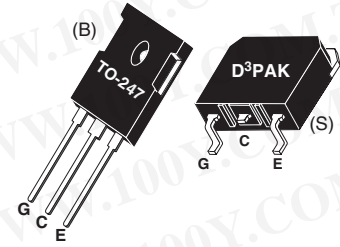

勝特力材料 886-3-5753170
 勝特力电子(上海) 86-21-34970699
 勝特力电子(深圳) 86-755-83298787
[Http://www.100y.com.tw](http://www.100y.com.tw)



MAXMUM RATINGS

Symbol	Parameter	APT60GT60BR_SRG	Unit
V_{CES}	Collector-Emitter Voltage	600	Volts
V_{GE}	Gate Emitter Voltage	±20	
I_{C1}	Continuous Collector Current @ $T_c = 25^\circ C$ $4\pm$	100	Amps
I_{C2}	Continuous Collector Current @ $T_c = 105^\circ C$	60	
I_{CM}	Pulsed Collector Current ¹ @ $T_c = 25^\circ C$	360	
I_{LM}	RBSOA Clamped Inductive Load Current $R_g = 11\Omega, T_c = 25^\circ C$	360	
E_{AS}	Single Pulse Avalanche Energy ²	65	mJ
P_D	Total Power Dissipation	500	Watts
T_J, T_{STG}	Operating and Storage Junction Temperature Range	-55 to 150	°C
T_L	Max. Lead Temp. for Soldering: 0.063" from Case for 10 Sec.	300	

STATIC ELECTRICAL CHARACTERISTICS

Symbol	Characteristic / Test Conditions	MIN	TYP	MAX	UNIT
BV_{CES}	Collector-Emitter Breakdown Voltage ($V_{GE} = 0V, I_C = 0.5mA$)	600			Volts
$V_{GE(TH)}$	Gate Threshold Voltage ($V_{CE} = V_{GE}, I_C = 500\mu A, T_j = 25^\circ C$)	3	4	5	
$V_{CE(ON)}$	Collector-Emitter On Voltage ($V_{GE} = 15V, I_C = I_{C2}, T_j = 25^\circ C$)	1.6	2.2	2.5	
	Collector-Emitter On Voltage ($V_{GE} = 15V, I_C = I_{C2}, T_j = 125^\circ C$)			2.8	
I_{CES}	Collector Cut-off Current ($V_{CE} = V_{CES}, V_{GE} = 0V, T_j = 25^\circ C$)			80	μA
	Collector Cut-off Current ($V_{CE} = V_{CES}, V_{GE} = 0V, T_j = 125^\circ C$)			2000	
I_{GES}	Gate-Emitter Leakage Current ($V_{GE} = \pm 20V, V_{CE} = 0V$)			±100	nA



CAUTION: These Devices are Sensitive to Electrostatic Discharge. Proper Handling Procedures Should Be Followed.

DYNAMIC CHARACTERISTICS

APT60GT60BR_SRG

Symbol	Characteristic	Test Conditions	MIN	TYP	MAX	UNIT
C_{ies}	Input Capacitance	Capacitance $V_{GE} = 0V$ $V_{CE} = 25V$ $f = 1\text{ MHz}$		3125	3590	pF
C_{oes}	Output Capacitance			310	450	
C_{res}	Reverse Transfer Capacitance			180	310	
Q_g	Total Gate Charge ³	Gate Charge $V_{GE} = 15V$ $V_{CC} = 0.5V_{CES}$ $I_C = I_{C2}$		275	410	nC
Q_{ge}	Gate-Emitter Charge			19	30	
Q_{gc}	Gate-Collector ("Miller") Charge			120	180	
$t_{d(on)}$	Turn-on Delay Time	Resistive Switching (25°C) $V_{GE} = 15V$ $V_{CC} = 0.5V_{CES}$ $I_C = I_{C2}$ $R_G = 10\Omega$		20	40	ns
t_r	Rise Time			95	190	
$t_{d(off)}$	Turn-off Delay Time			315	470	
t_f	Fall Time			245	490	
$t_{d(on)}$	Turn-on Delay Time	Inductive Switching (150°C) $V_{CLAMP(Peak)} = 0.66V_{CES}$ $V_{GE} = 15V$ $I_C = I_{C2}$ $R_G = 10\Omega$ $T_J = +150^\circ C$		25	50	ns
t_r	Rise Time			59	120	
$t_{d(off)}$	Turn-off Delay Time			430	650	
t_f	Fall Time			65	130	
E_{on}	Turn-on Switching Energy			1.6	3.2	
E_{off}	Turn-off Switching Energy		2.4	4.8	mJ	
E_{ts}	Total Switching Losses		4.0	8.0		
$t_{d(on)}$	Turn-on Delay Time	Inductive Switching (25°C) $V_{CLAMP(Peak)} = 0.66V_{CES}$ $V_{GE} = 15V$ $I_C = I_{C2}$ $R_G = 5\Omega$ $T_J = +25^\circ C$		26	50	ns
t_r	Rise Time			63	125	
$t_{d(off)}$	Turn-off Delay Time			395	590	
t_f	Fall Time			68	140	
E_{ts}	Total Switching Losses			3.4	7.0	
g_{fe}	Forward Transconductance	$V_{CE} = 20V, I_C = I_{C2}$	4			S

THERMAL AND MECHANICAL CHARACTERISTICS

Symbol	Characteristic	MIN	TYP	MAX	UNIT
$R_{\theta JC}$	Junction to Case			0.25	°C/W
$R_{\theta JA}$	Junction to Ambient			40	
W_T	Package Weight		0.22		oz
			6.1		gm
Torque	Mounting Torque (using a 6-32 or 3mm Binding Head Machine Screw)			10	lb•in
				1.1	N•m

① Repetitive Rating: Pulse width limited by maximum junction temperature.

② $I_C = I_{C2}$, $R_{GE} = 25\Omega$, $L = 36\mu H$, $T_J = 25^\circ C$

③ See MIL-STD-750 Method 3471

④ The maximum current is limited by lead temperature.

Microsemi Reserves the right to change, without notice, the specifications and information contained herein.

勝特力材料 886-3-5753170
 勝特力电子(上海) 86-21-34970699
 勝特力电子(深圳) 86-755-83298787
[Http://www.100y.com.tw](http://www.100y.com.tw)

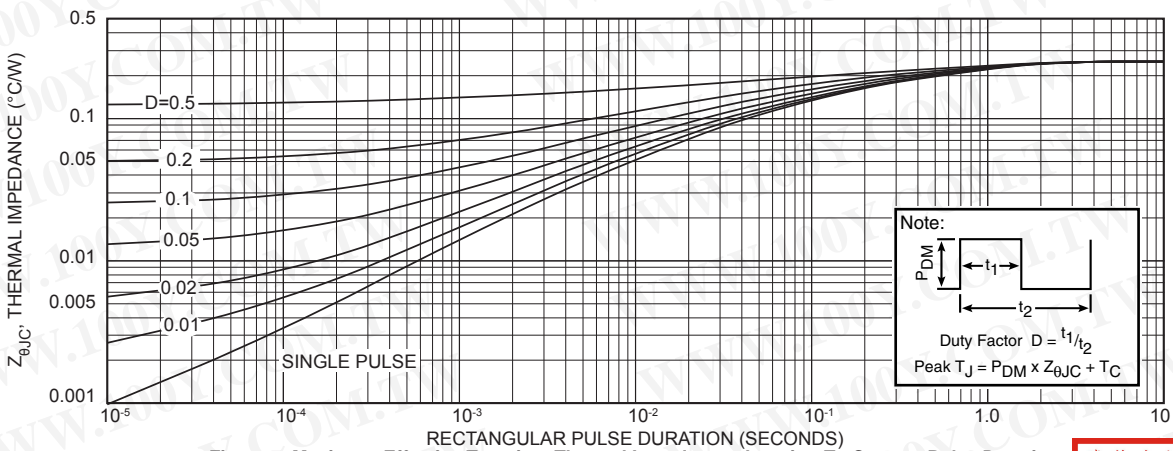
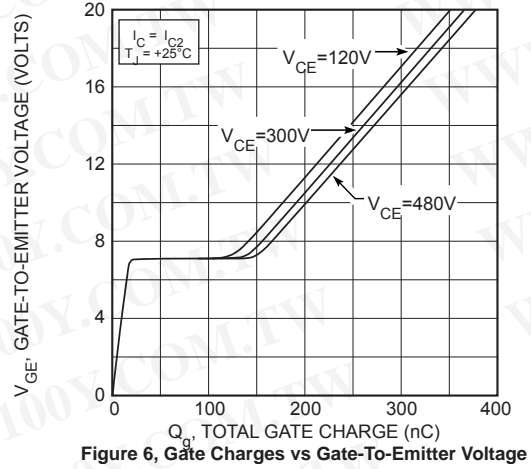
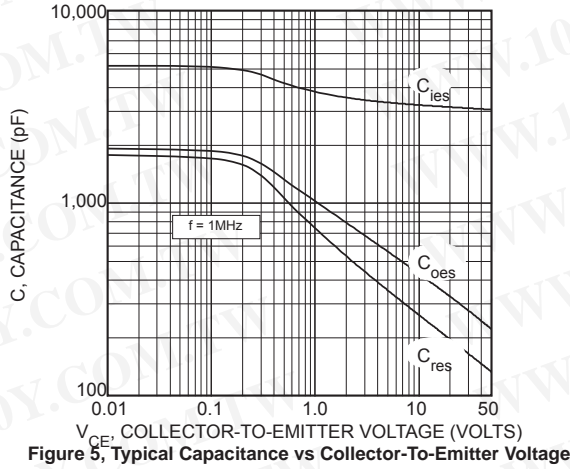
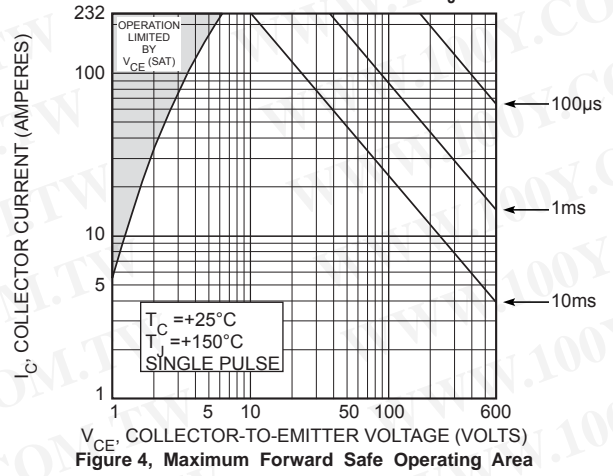
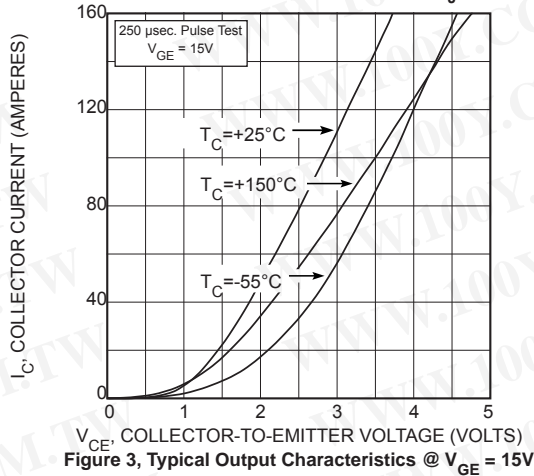
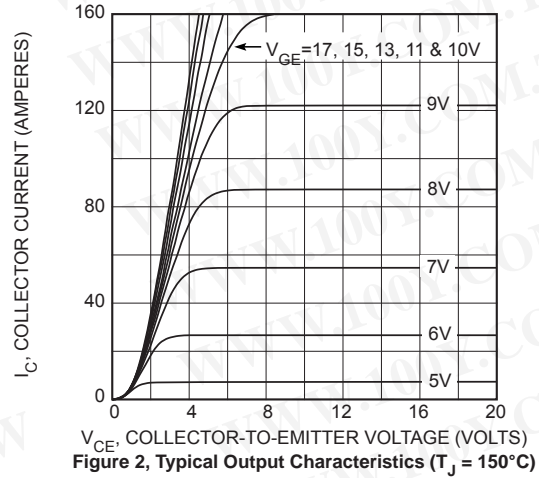
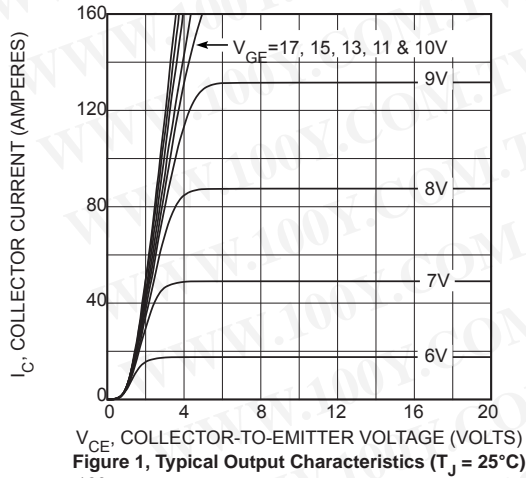

勝特力材料 886-3-5753170
 勝特力电子(上海) 86-21-34970699
 勝特力电子(深圳) 86-755-83298787
[Http://www.100y.com.tw](http://www.100y.com.tw)

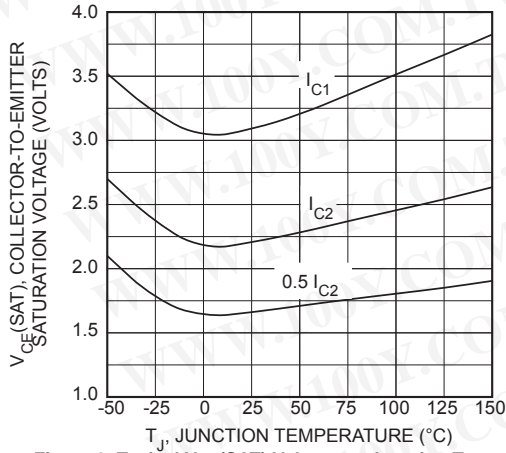

Figure 8, Typical $V_{CE(SAT)}$ Voltage vs Junction Temperature

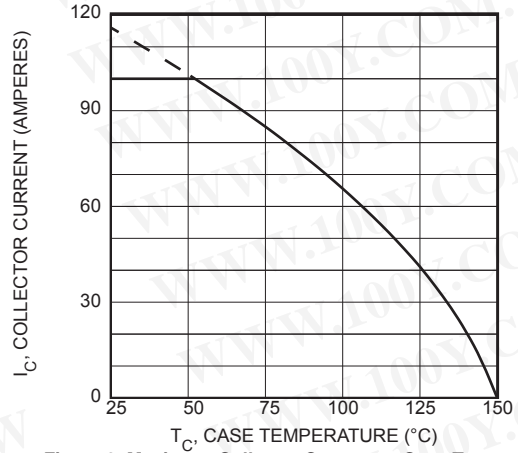

Figure 9, Maximum Collector Current vs Case Temperature

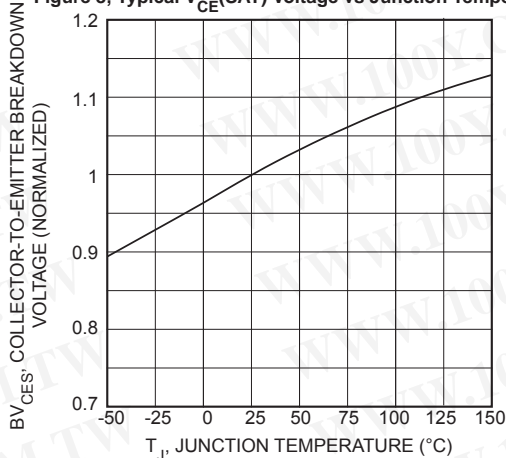

Figure 10, Breakdown Voltage vs Junction Temperature

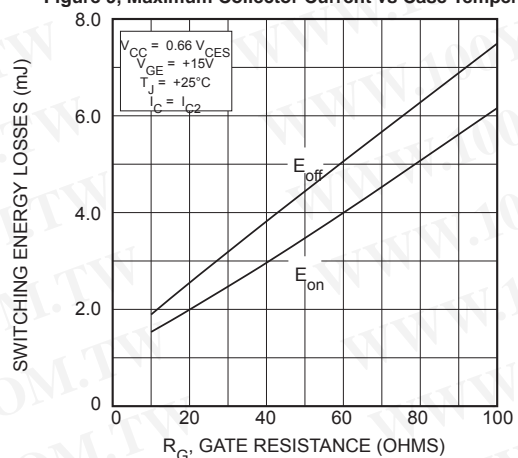

Figure 11, Typical Switching Energy Losses vs Gate Resistance

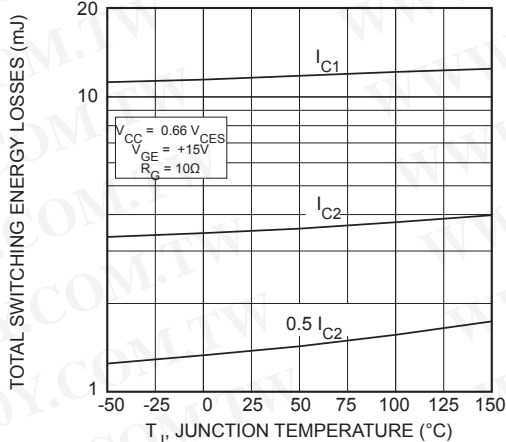

Figure 12, Typical Switching Energy Losses vs. Junction Temperature

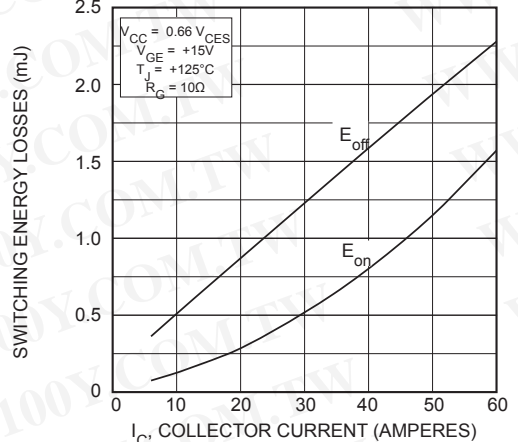

Figure 13, Typical Switching Energy Losses vs Collector Current

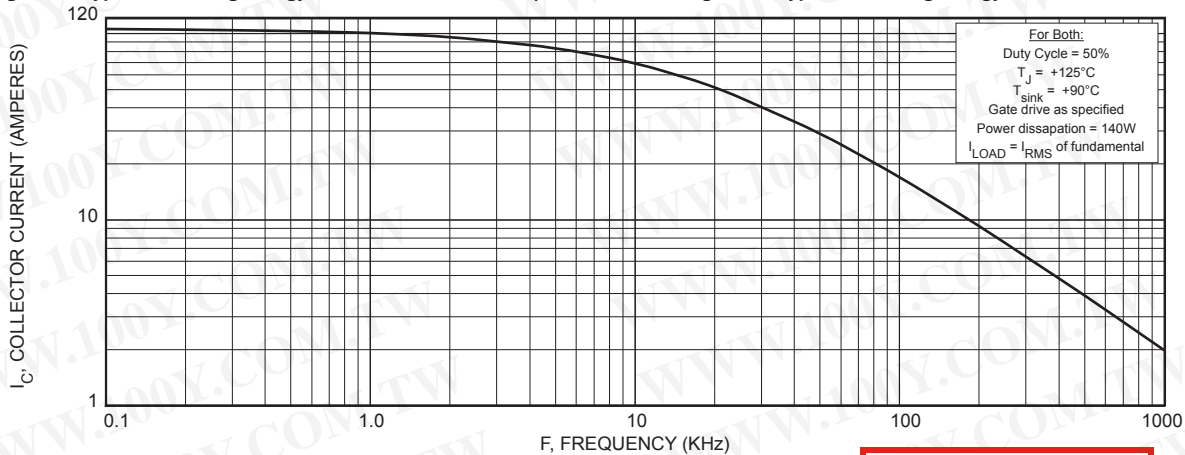

Figure 14, Typical Load Current vs Frequency

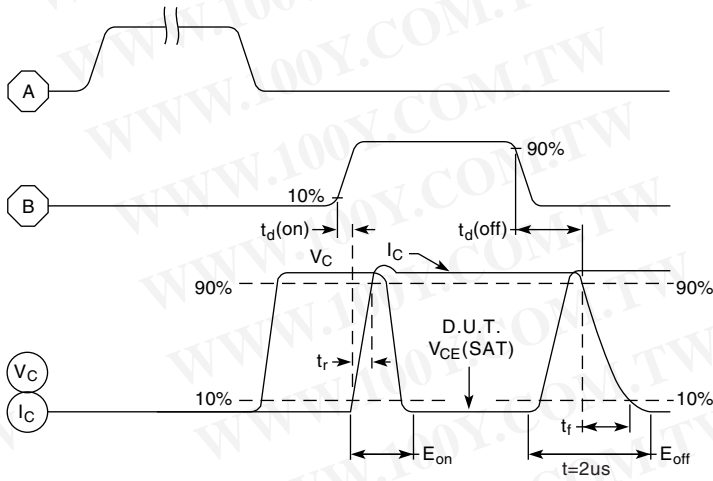

Figure 15, Switching Loss Test Circuit and Waveforms

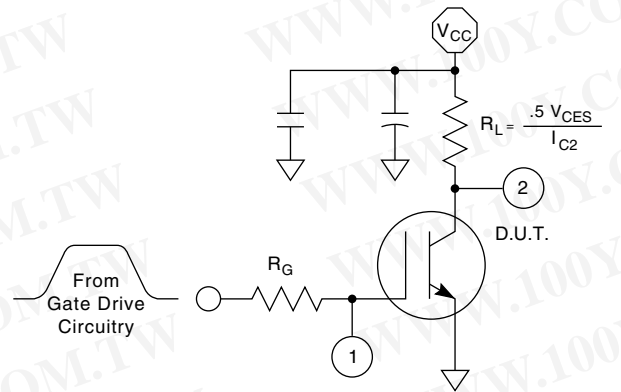
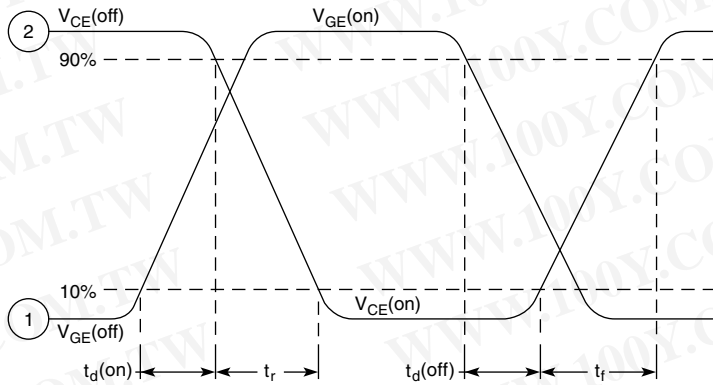
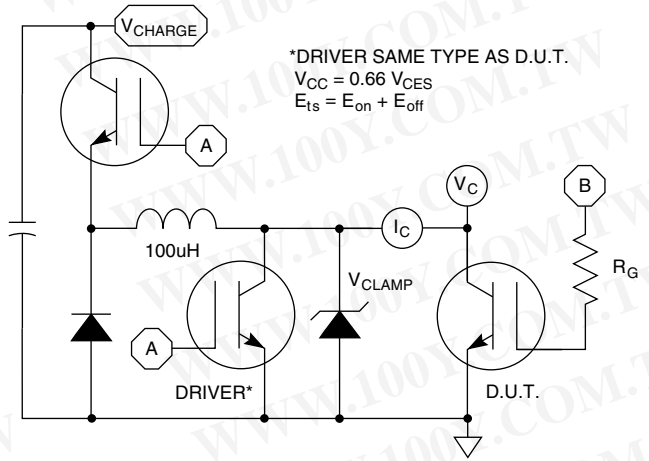
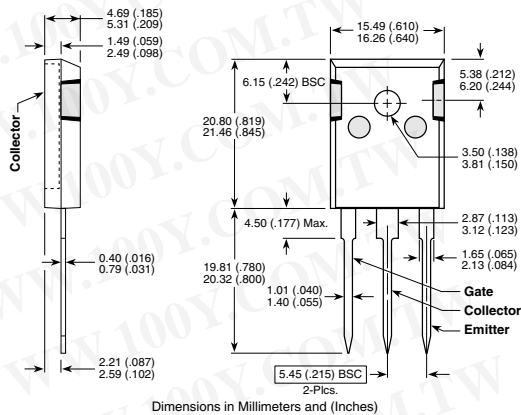

Figure 16, Resistive Switching Time Test Circuit and Waveforms

勝特力材料 886-3-5753170
 勝特力电子(上海) 86-21-34970699
 勝特力电子(深圳) 86-755-83298787
[Http://www.100y.com.tw](http://www.100y.com.tw)

TO-247 Package Outline
e1 SAC: Tin, Silver, Copper



D³PAK Package Outline
e3 SAC: Tin, Silver, Copper

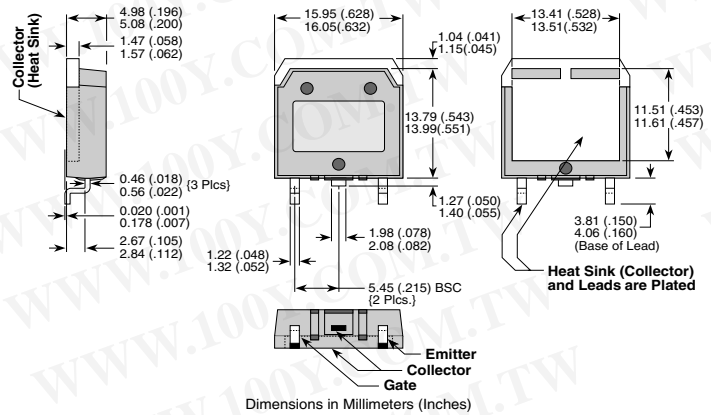

Microsemi's products are covered by one or more of U.S. patents 4,895,810 5,045,903 5,089,434 5,182,234 5,019,522 5,262,336 6,503,786 5,256,583 4,748,103 5,283,202 5,231,474 5,434,095 5,528,058 6,939,743, 7,352,045 5,283,201 5,801,417 5,648,283 7,196,634 6,664,594 7,157,886 6,939,743 7,342,262 and foreign patents. US and Foreign patents pending. All Rights Reserved.