

A-405



Features

- ◇ High efficiency, low VF
- ◇ High current capability
- ◇ High reliability
- ◇ High surge current capability
- ◇ Low power loss
- ◇ For use in low voltage, high frequency inverter, Free wheeling, and polarity protection application
- ◇ Green compound with suffix "G" on packing code & prefix "G" on datecode

Mechanical Data

- ◇ Case: Molded plastic
- ◇ Epoxy: UL 94V-0 rate flame retardant
- ◇ Lead: Pure tin plated, lead free, solderable per MIL-STD-202, Method 208 guaranteed
- ◇ Polarity: Color band denotes cathode
- ◇ High temperature soldering guaranteed: 260°C/10 seconds/.375"(9.5mm) lead lengths at 5 lbs., (2.3kg) tension
- ◇ Mounting position: Any
- ◇ Weight: 0.22 grams

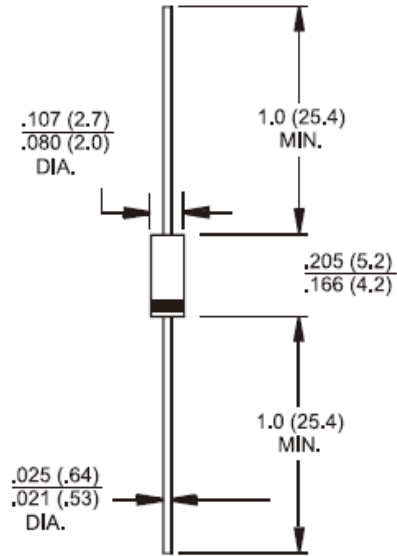

Dimensions in inches and (millimeters)

Marking Diagram



- SFXXSG = Specific Device Code
- G = Green Compound
- Y = Year
- WW = Work Week

Maximum Ratings and Electrical Characteristics

Rating at 25 °C ambient temperature unless otherwise specified.

Single phase, half wave, 60 Hz, resistive or inductive load.

For capacitive load, derate current by 20%

Type Number	Symbol	SF 11SG	SF 12SG	SF 13SG	SF 14SG	SF 15SG	SF 16SG	SF 17SG	SF 18SG	Units	
Maximum Recurrent Peak Reverse Voltage	V_{RRM}	50	100	150	200	300	400	500	600	V	
Maximum RMS Voltage	V_{RMS}	35	70	105	140	210	280	350	420	V	
Maximum DC Blocking Voltage	V_{DC}	50	100	150	200	300	400	500	600	V	
Maximum Average Forward Rectified Current .375 (9.5mm) Lead Length @ $T_A = 55^\circ C$	$I_{F(AV)}$	1								A	
Peak Forward Surge Current, 8.3 ms Single Half Sine-wave Superimposed on Rated Load (JEDEC method)	I_{FSM}	30								A	
Maximum Instantaneous Forward Voltage (Note 1) @ 1 A	V_F	0.95			1.3		1.7			V	
Maximum DC Reverse Current at Rated DC Blocking Voltage @ $T_A = 25^\circ C$ @ $T_A = 125^\circ C$	I_R	5					100				uA
Maximum Reverse Recovery Time (Note 2)	T_{rr}	35									nS
Typical Junction Capacitance (Note 3)	C_j	20				10				pF	
Typical Thermal Resistance (Note 4)	$R_{\theta JA}$	95									$^\circ C/W$
Operating Temperature Range	T_J	- 65 to + 150									$^\circ C$
Storage Temperature Range	T_{STG}	- 65 to + 150									$^\circ C$

Note 1: Pulse Test with PW=300 usec, 1% Duty Cycle

Note 2: Reverse Recovery Test Conditions: $I_F=0.5A$, $I_R=1.0A$, $I_{RR}=0.25A$

Note 3: Measured at 1 MHz and Applied Reverse Voltage of 4.0V D.C.

Note 4: Mount on Cu-Pad Size 5mm x 5mm on PCB.

RATINGS AND CHARACTERISTIC CURVES (SF11SG THRU SF18SG)

FIG.1- MAXIMUM AVERAGE FORWARD CURRENT DERATING

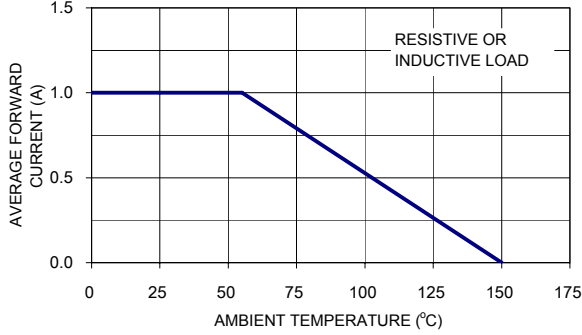

FIG.2- TYPICAL REVERSE CHARACTERISTICS

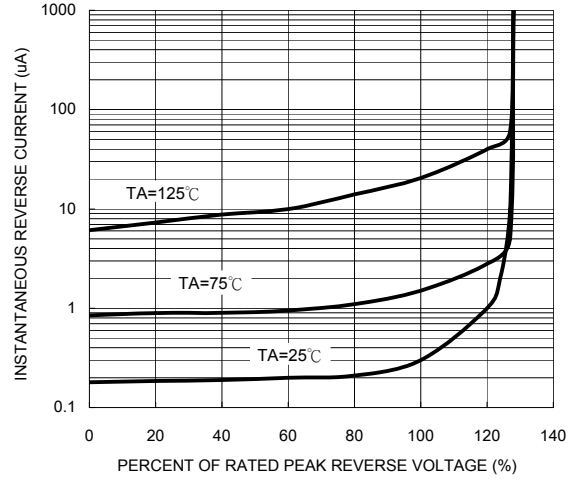

FIG. 3- MAXIMUM NON-REPETITIVE FORWARD SURGE CURRENT

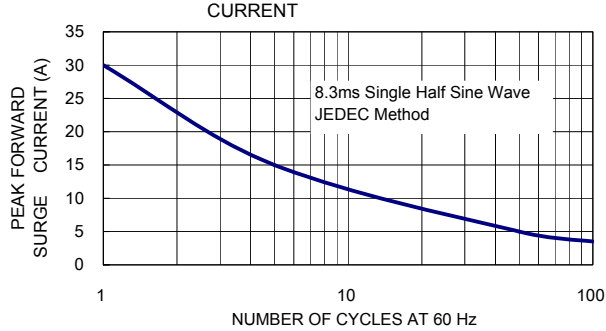

FIG. 5- TYPICAL FORWARD CHARACTERISTICS

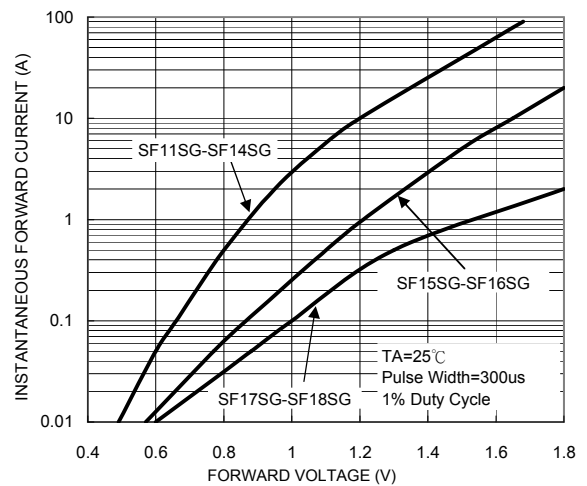

FIG. 4- TYPICAL JUNCTION CAPACITANCE

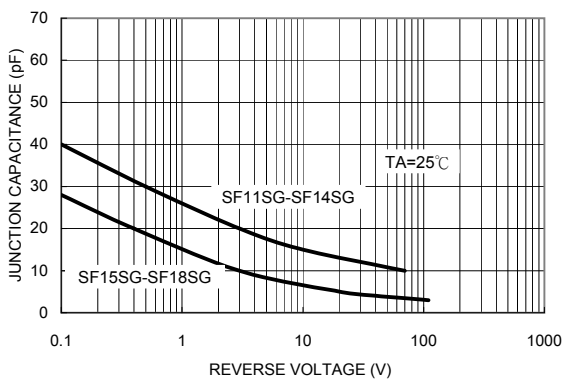

FIG.6- REVERSE RECOVERY TIME CHARACTERISTIC AND TEST CIRCUIT DIAGRAM

