

D²PAK

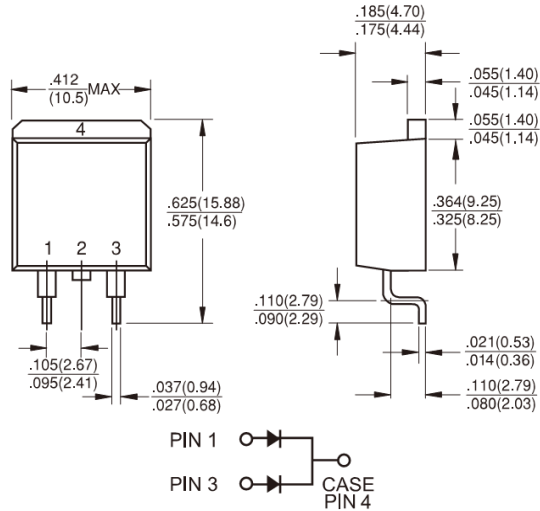

Features

- ✧ UL Recognized File #E-326854
- ✧ Glass passivated junction chip
- ✧ High efficiency, low VF
- ✧ High current capability
- ✧ High reliability
- ✧ High surge current capability
- ✧ Low power loss
- ✧ For use in low voltage, high frequency inverter, free wheeling, and polarity protection application
- ✧ Qualified as per AEC-Q101
- ✧ Green compound with suffix "G" on packing code & prefix "G" on datecode



Mechanical Data

- ✧ Case: Molded plastic
- ✧ Epoxy: UL 94V-0 rate flame retardant
- ✧ Terminals: Pure tin plated, lead free, solderable per MIL-STD-202, Method 208 guaranteed
- ✧ Polarity: As marked
- ✧ High temperature soldering: 260°C/10 seconds/.16", (4.06mm) from case
- ✧ Weight: 1.41 grams

Dimensions in inches and (millimeters)

Marking Diagram



- SFS160XG = Specific Device Code
- G = Green Compound
- Y = Year
- WW = Work Week

Maximum Ratings and Electrical Characteristics

Rating at 25 °C ambient temperature unless otherwise specified.

Single phase, half wave, 60 Hz, resistive or inductive load.

For capacitive load, derate current by 20%

Type Number	Symbol	SFS 1601G	SFS 1602G	SFS 1603G	SFS 1604G	SFS 1605G	SFS 1606G	SFS 1607G	SFS 1608G	Unit	
Maximum Repetitive Peak Reverse Voltage	V_{RRM}	50	100	150	200	300	400	500	600	V	
Maximum RMS Voltage	V_{RMS}	35	70	105	140	210	280	350	420	V	
Maximum DC Blocking Voltage	V_{DC}	50	100	150	200	300	400	500	600	V	
Maximum Average Forward Rectified Current @ $T_C=100^\circ C$	$I_{F(AV)}$	16								A	
Peak Forward Surge Current, 8.3 ms Single Half Sine-wave Superimposed on Rated Load (JEDEC method)	I_{FSM}	125								A	
Maximum Instantaneous Forward Voltage (Note 1) @ 8 A	V_F	0.975			1.3		1.7			V	
Maximum DC Reverse Current @ Rated DC Blocking Voltage	I_R	$T_A=25^\circ C$				$T_A=100^\circ C$					uA
Maximum Reverse Recovery Time (Note 2)	T_{rr}	35								nS	
Typical Junction Capacitance (Note 3)	C_j	80				60				pF	
Typical Thermal Resistance	$R_{\theta JC}$	2.5								$^\circ C/W$	
Operating Temperature Range	T_J	- 65 to + 150								$^\circ C$	
Storage Temperature Range	T_{STG}	- 65 to + 150								$^\circ C$	

Note 1: Pulse Test with PW=300usec, 1% Duty Cycle

Note 2: Reverse Recovery Test Conditions: $I_F=0.5A$, $I_R=1.0A$, $I_{RR}=0.25A$

Note 3: Measured at 1 MHz and Applied Reverse Voltage of 4.0V D.C.

RATINGS AND CHARACTERISTIC CURVES (SFS1601G THRU SFS1608G)

FIG.1 FORWARD CURRENT DERATING CURVE

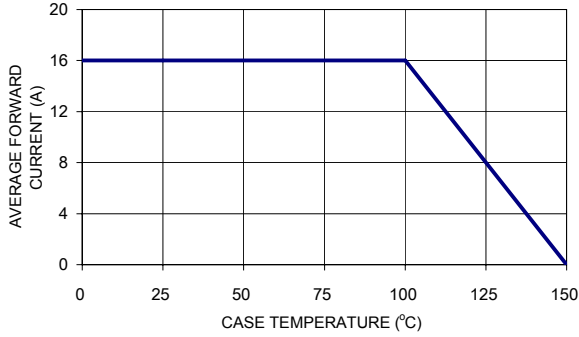

FIG. 2 TYPICAL REVERSE CHARACTERISTICS

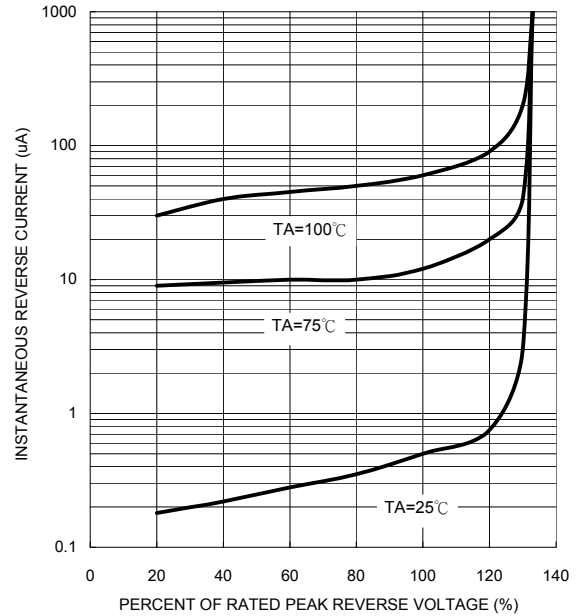

FIG. 3 MAXIMUM NON-REPETITIVE FORWARD SURGE CURRENT

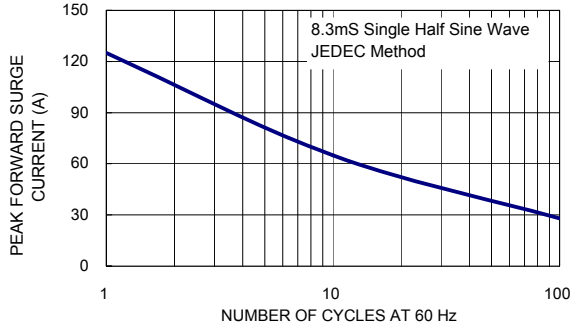

FIG. 5 TYPICAL FORWARD CHARACTERISTICS

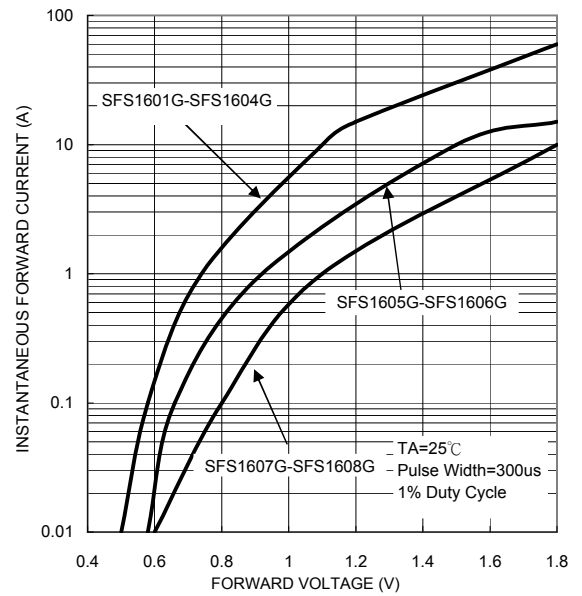

FIG. 4 TYPICAL JUNCTION CAPACITANCE

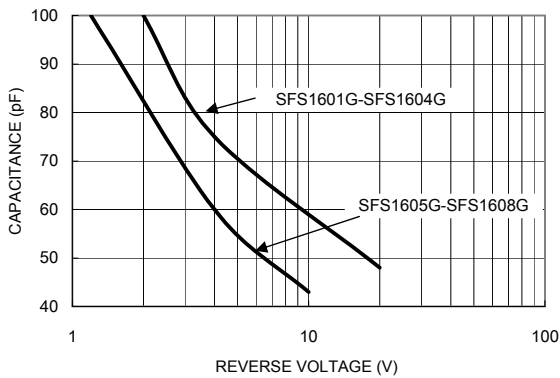

FIG.6- REVERSE RECOVERY TIME CHARACTERISTIC AND TEST CIRCUIT DIAGRAM

