

Features

- ✧ For surface mounted application
- ✧ Metal to silicon rectifier, majority carrier conduction
- ✧ Low forward voltage drop
- ✧ Easy pick and place
- ✧ High surge current capability
- ✧ Plastic material used carriers Underwriters Laboratory Classfication 94V-0
- ✧ Meet MSL level 1, per J-STD-020D, lead free maximum peak of 260°C
- ✧ Epitaxial construction
- ✧ High temperature soldering guaranteed: 260°C/10s at terminals
- ✧ Green compound with suffix "G" on packing code & prefix "G" on datecode



Mechanical Data

- ✧ Case: Molded plastic
- ✧ Terminal: Pure tin plated, lead free
- ✧ Polarity: Indicated by cathode band
- ✧ Packaging: 8mm tape per EIA STD RS-481
- ✧ Weight: 0.093 grams

Ordering Information (example)

Part No.	Package	Packing	Packing code	Green Compound Packing code
SK12B	SMB	850 / 7" REEL	R5	R5G

Maximum Ratings and Electrical Characteristics

Rating at 25 °C ambient temperature unless otherwise specified.

Single phase, half wave, 60 Hz, resistive or inductive load.

For capacitive load, derate current by 20%

Type Number	Symbol	SK 12B	SK 13B	SK 14B	SK 15B	SK 16B	SK 19B	SK 110B	SK 115B	Units	
Maximum Recurrent Peak Reverse Voltage	V_{RRM}	20	30	40	50	60	90	100	150	V	
Maximum RMS Voltage	V_{RMS}	14	21	28	35	42	63	70	105	V	
Maximum DC Blocking Voltage	V_{DC}	20	30	40	50	60	90	100	150	V	
Maximum Average Forward Rectified Current	$I_{F(AV)}$	1								A	
Peak Forward Surge Current, 8.3 ms Single Half Sine-wave Superimposed on Rated Load (JEDEC method)	I_{FSM}	30								A	
Maximum Instantaneous Forward Voltage (Note 1) @ 1 A	V_F	0.50		0.75		0.85		0.95		V	
Maximum DC Reverse Current at Rated DC Blocking Voltage @ $T_A=25\text{ }^\circ\text{C}$ @ $T_A=100\text{ }^\circ\text{C}$ @ $T_A=125\text{ }^\circ\text{C}$	I_R	0.5					0.1				mA
		10			5		-				
		-					2				
Typical Junction Capacitance (Note 2)	C_j	110								pF	
Typical Thermal Resistance	$R_{\theta JL}$	25								$^\circ\text{C/W}$	
Operating Temperature Range	T_J	- 55 to + 125				- 55 to + 150				$^\circ\text{C}$	
Storage Temperature Range	T_{STG}	- 55 to + 150									$^\circ\text{C}$

Note 1: Pulse Test with PW=300 usec, 1% Duty Cycle

Note 2: Measured at 1.0 MHz and Applies Reverse Voltage of 4.0V

RATINGS AND CHARACTERISTIC CURVES (SK12B THRU SK115B)

FIG.1- MAXIMUM FORWARD CURRENT DERATING CURVE

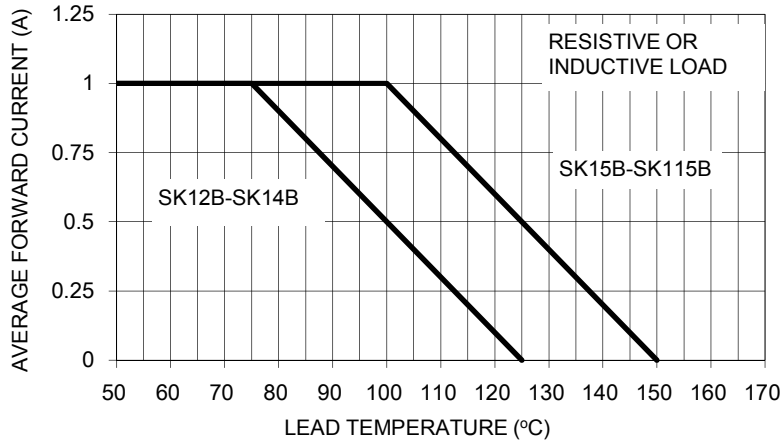

FIG. 2 MAXIMUM NON-REPETITIVE FORWARD SURGE CURRENT

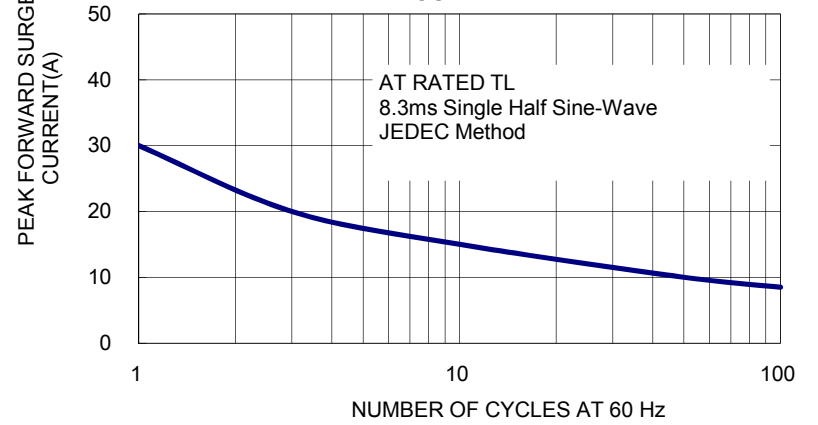

FIG. 3 TYPICAL FORWARD CHARACTERISTICS

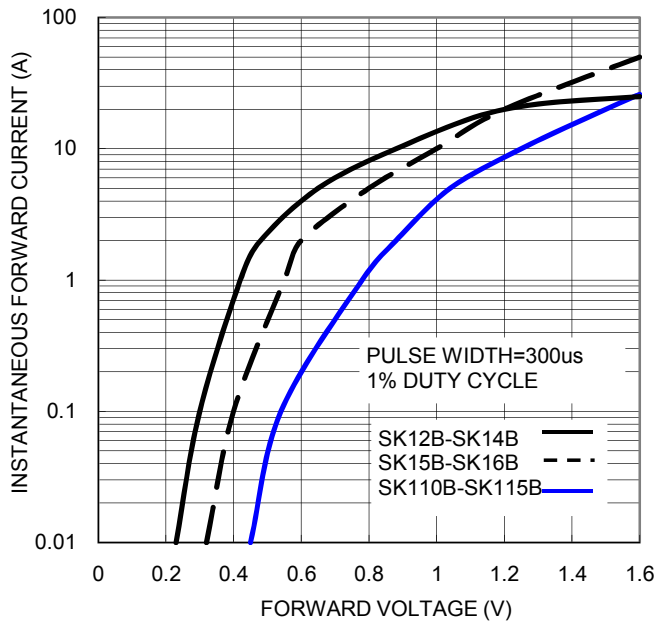

FIG. 4 TYPICAL REVERSE CHARACTERISTICS

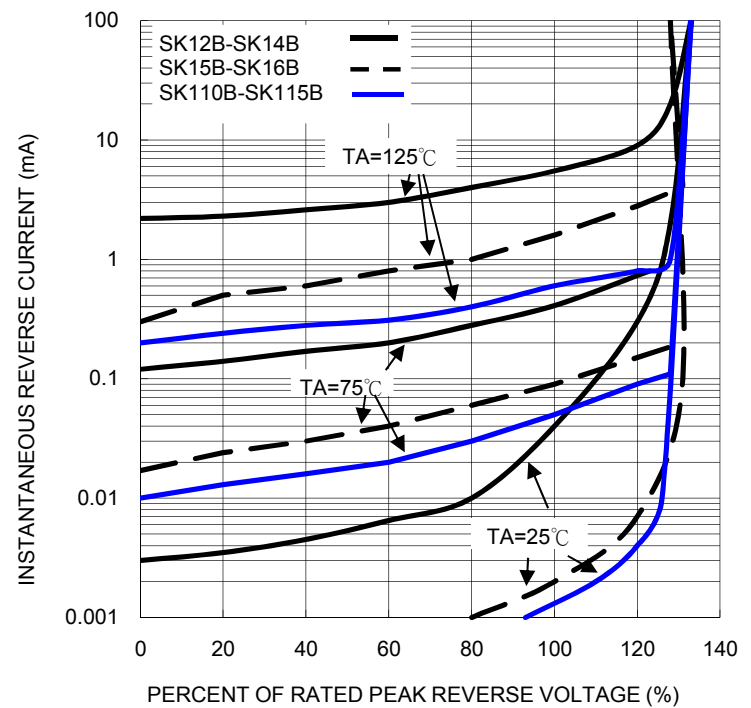

FIG. 5 TYPICAL JUNCTION CAPACITANCE

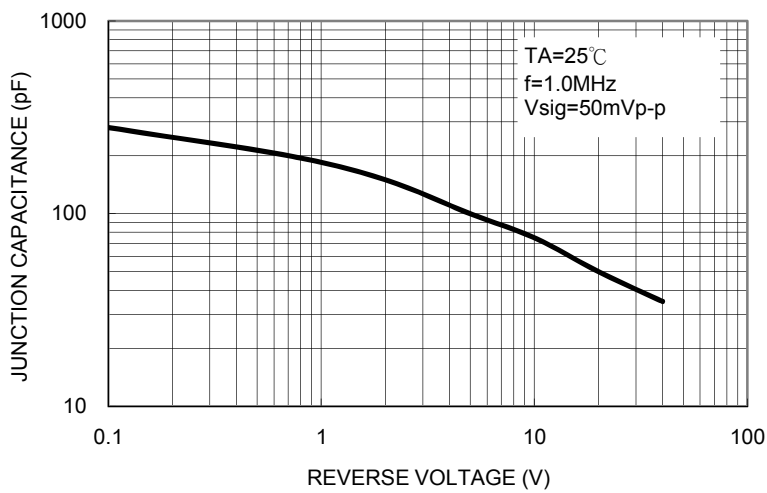
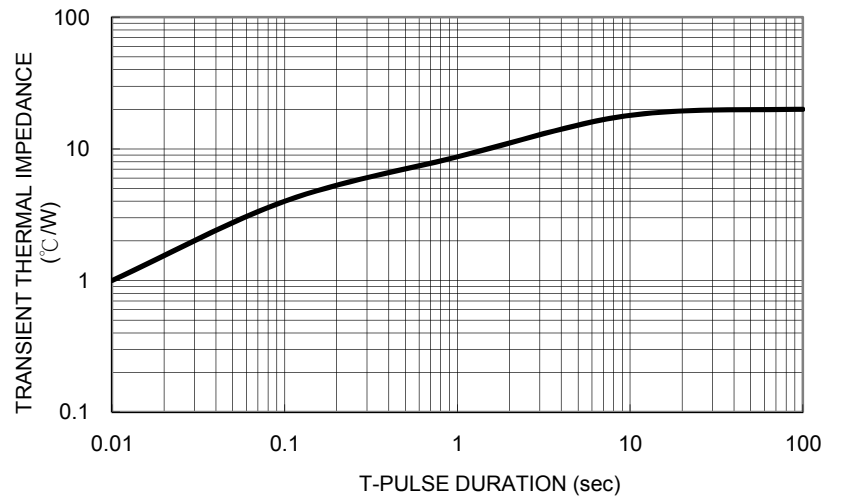

FIG. 6 TYPICAL TRANSIENT THERMAL CHARACTERISTICS



Ordering information

Part No.	Package	Packing	Packing code	Green Compound Packing code
SK1XB (Note)	SMB	850 / 7" REEL	R5	R5G
	SMB	3K / 13" REEL	R4	R4G

Note: "x" is Device Code from "2" thru "15".

Tape & Reel specification

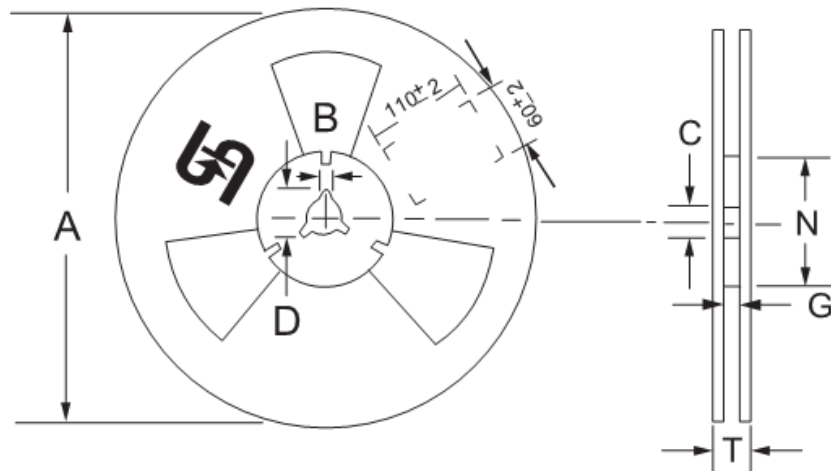
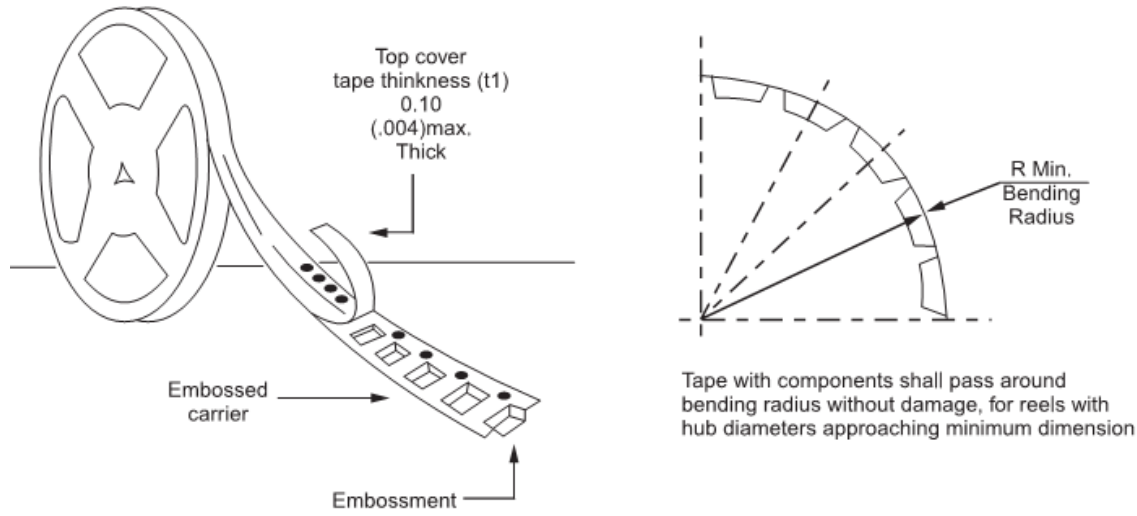

Reel Size	Tape Size	A	B	C	D	N	G	T
		±2.0	±0.4	+0.5;-0.2	min	±1.0	+0.8;-0	max
7"	12mm	178	1.9	13	21	62	12.2	14.6
Reel Size	Tape Size	A	B	C	D	N	G	T
		max	±0.5	±0.5	min	±0.5	+2.0;-0	max
13"	12mm	330	2	13	20.2	75	12.4	18.4

Unit (mm)

Suggested PAD Layout

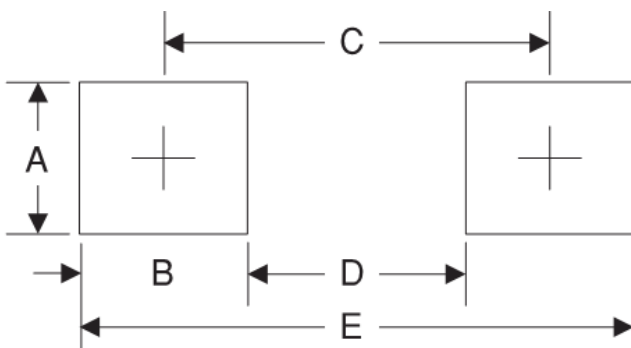

Symbol	Unit(mm)
A	2.3
B	2.5
C	4.3
D	1.8
E	6.7

Dimensions

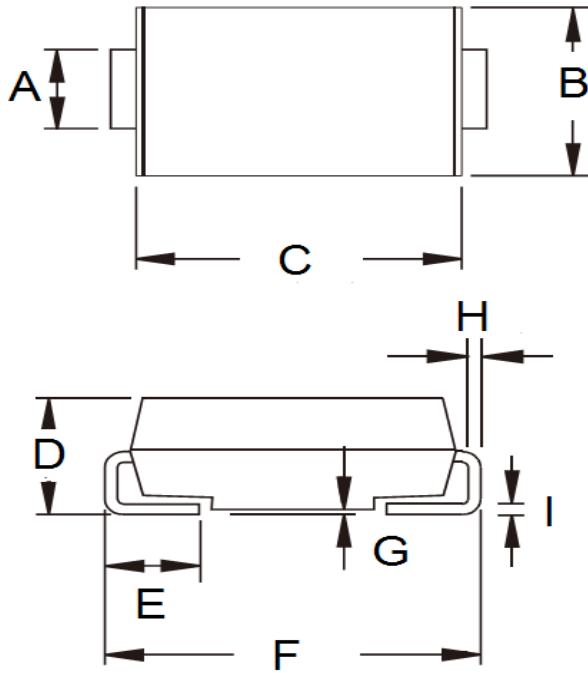

DIM.	Unit(mm)		Unit(inch)	
	Min	Max	Min	Max
A	1.95	2.10	0.077	0.083
B	3.48	3.73	0.137	0.147
C	4.25	4.75	0.167	0.187
D	1.99	2.61	0.078	0.103
E	0.90	1.41	0.035	0.056
F	5.10	5.30	0.201	0.209
G	0.10	0.20	0.004	0.008
H	0.15	0.31	0.006	0.012
I	0.15	0.31	0.006	0.012

Marking Diagram

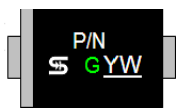

P/N = Specific Device Code
 G = Green Compound
 YW = Date Code