

Features

- ✧ For surface mounted application
- ✧ Metal to silicon rectifier, majority carrier conduction
- ✧ Low forward voltage drop
- ✧ Easy pick and place
- ✧ High surge current capability
- ✧ Plastic material used carriers Underwriters Laboratory Classification 94V-0
- ✧ Epitaxial construction
- ✧ Meet MSL level 1, per J-STD-020D, lead free maximum peak of 260°C
- ✧ High temperature soldering: 260°C/10 seconds at terminals
- ✧ Green compound with suffix "G" on packing code & prefix "G" on datecode



Mechanical Data

- ✧ Case: Molded plastic
- ✧ Terminals: Pure tin plated, lead free
- ✧ Polarity: Indicated by cathode band
- ✧ Packaging: 12mm tape per EIA Std RS-481
- ✧ Weight: 0.1 gram

Ordering Information (example)

Part No.	Package	Packing	Packing code	Green Compound Packing code
SK52B	SMB	850 / 7" REEL	R5	R5G

Maximum Ratings and Electrical Characteristics

Rating at 25 °C ambient temperature unless otherwise specified.

Single phase, half wave, 60 Hz, resistive or inductive load.

For capacitive load, derate current by 20%

Type Number	Symbol	SK 52B	SK 53B	SK 54B	SK 55B	SK 56B	SK 59B	SK 510B	SK 515B	Unit
Maximum Repetitive Peak Reverse Voltage	V_{RRM}	20	30	40	50	60	90	100	150	V
Maximum RMS Voltage	V_{RMS}	14	21	28	35	42	63	70	105	V
Maximum DC Blocking Voltage	V_{DC}	20	30	40	50	60	90	100	150	V
Maximum Average Forward Rectified Current	$I_{F(AV)}$	5								A
Peak Forward Surge Current, 8.3 ms Single Half Sine-wave Superimposed on Rated Load (JEDEC method)	I_{FSM}	120								A
Maximum Instantaneous Forward Voltage (Note 1) @ 5 A	V_F	0.55		0.75		0.85		0.95		V
Maximum Reverse Current @ Rated VR $T_A=25^\circ\text{C}$ $T_A=100^\circ\text{C}$ $T_A=125^\circ\text{C}$	I_R	0.5				0.1				mA
		20		10		-				
		-				2				
Typical Thermal Resistance	$R_{\theta JL}$	19								°C/W
	$R_{\theta JA}$	60								
Operating Temperature Range	T_J	- 55 to + 150								°C
Storage Temperature Range	T_{STG}	- 55 to + 150								°C

Note 1: Pulse Test with PW=300 usec, 1% Duty Cycle

RATINGS AND CHARACTERISTIC CURVES (SK52B THRU SK515B)

FIG.1 FORWARD CURRENT DERATING CURVE

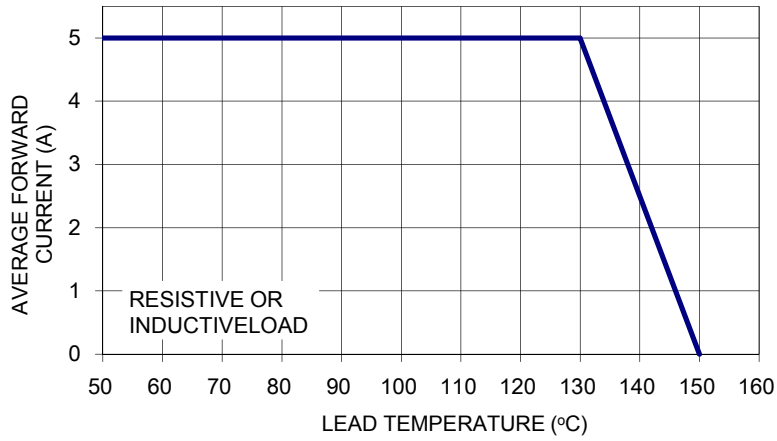

FIG. 2 MAXIMUM NON-REPETITIVE FORWARD SURGE CURRENT

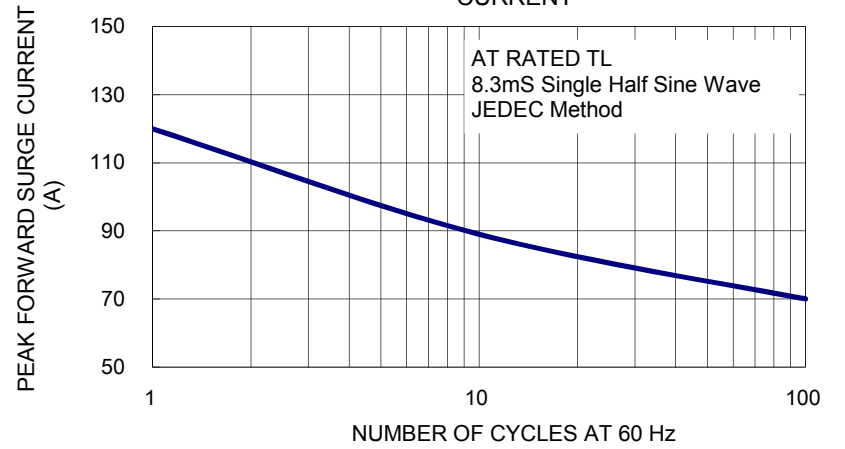

FIG. 3 TYPICAL FORWARD CHARACTERISTICS

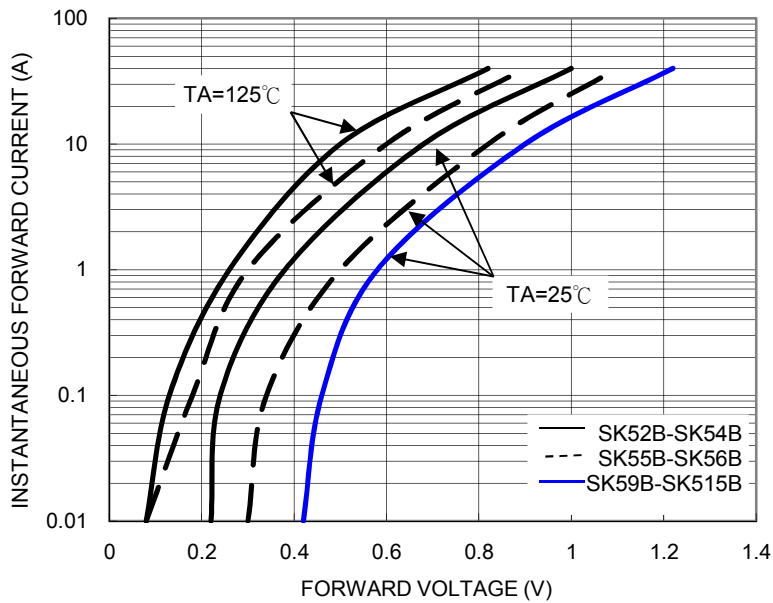

FIG. 4 TYPICAL REVERSE CHARACTERISTICS

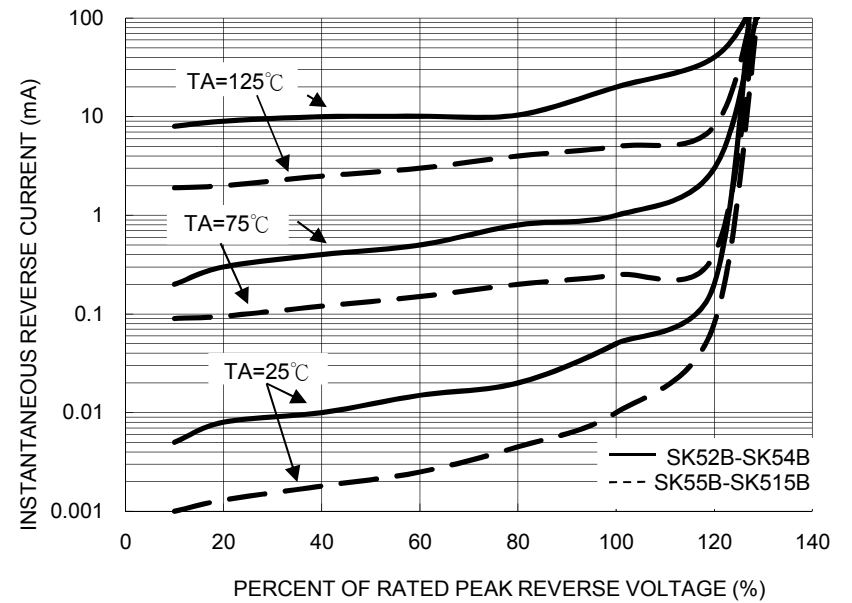

FIG. 5 TYPICAL JUNCTION CAPACITANCE

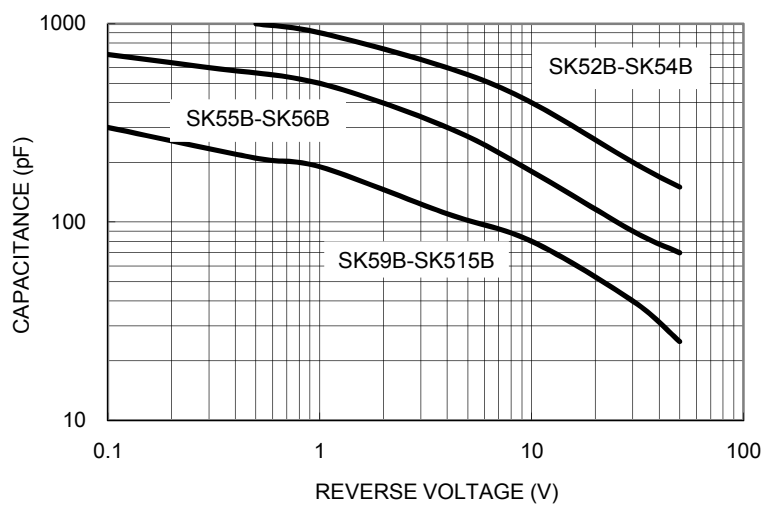
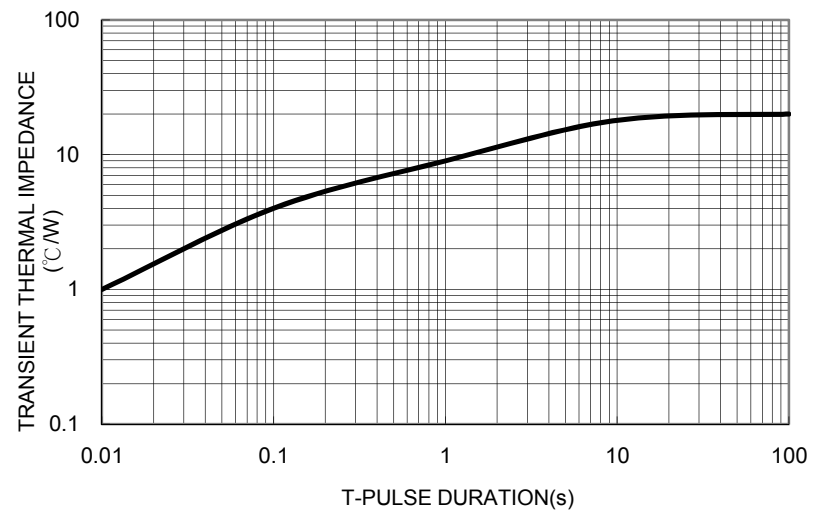

FIG. 6 TYPICAL TRANSIENT THERMAL IMPEDANCE



Ordering information

Part No.	Package	Packing	Packing code	Green Compound Packing code
SK5XB (Note)	SMB	850 / 7" REEL	R5	R5G
	SMB	3K / 13" REEL	R4	R4G

Note: "x" is Device Code from "2" thru "15".

Tape & Reel specification

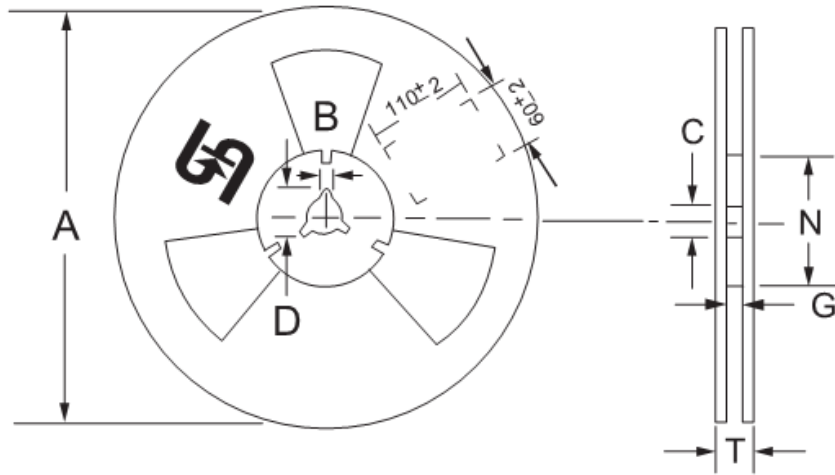
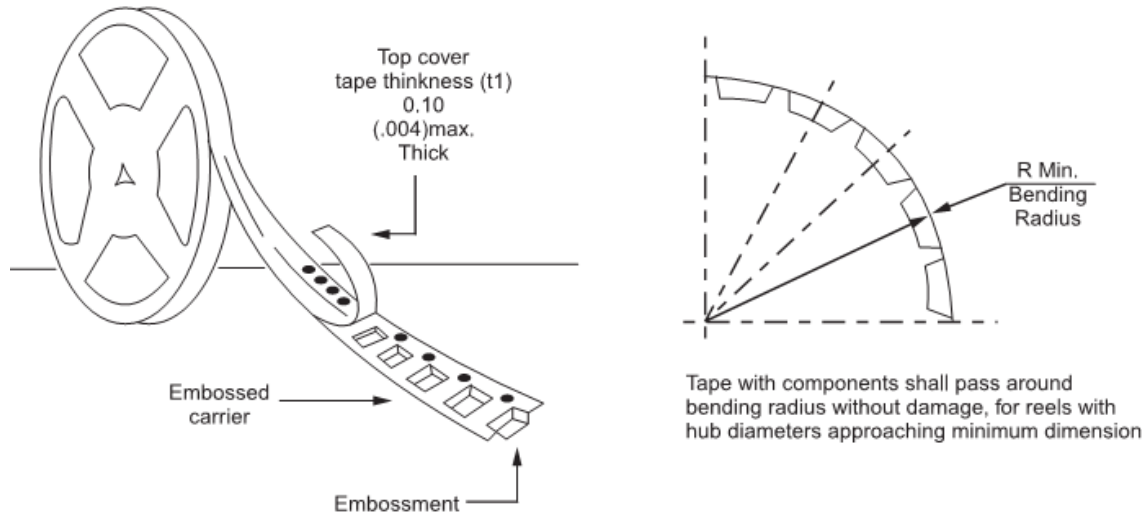

Reel Size	Tape Size	A	B	C	D	N	G	T
7"	12mm	±2.0	±0.4	+0.5;-0.2	min	±1.0	+0.8;-0	max
		178	1.9	13	21	62	12.2	14.6
13"	12mm	max	±0.5	±0.5	min	±0.5	+2.0;-0	max
		330	2	13	20.2	75	12.4	18.4

Unit (mm)

Suggested PAD Layout

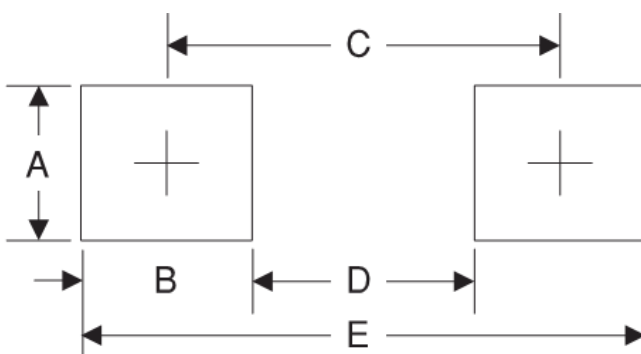

Symbol	Unit(mm)
A	2.3
B	2.5
C	4.3
D	1.8
E	6.7

Dimensions

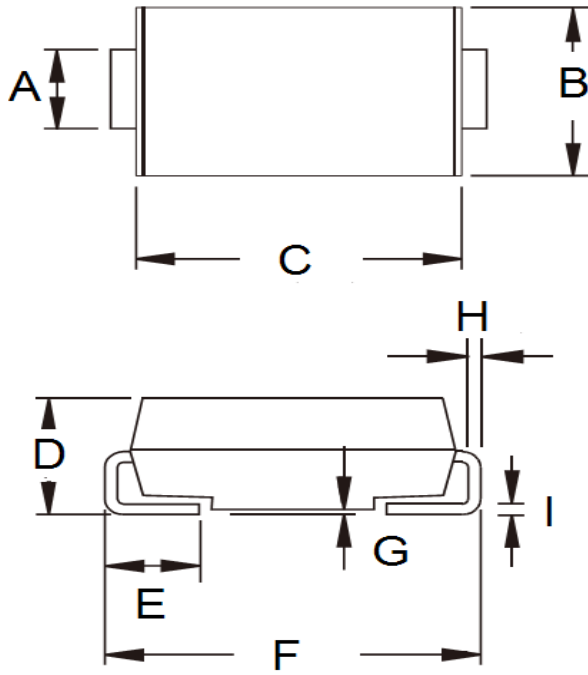

DIM.	Unit(mm)		Unit(inch)	
	Min	Max	Min	Max
A	1.95	2.10	0.077	0.083
B	3.48	3.73	0.137	0.147
C	4.25	4.75	0.167	0.187
D	1.99	2.61	0.078	0.103
E	0.90	1.41	0.035	0.056
F	5.10	5.30	0.201	0.209
G	0.10	0.20	0.004	0.008
H	0.15	0.31	0.006	0.012
I	0.15	0.31	0.006	0.012

Marking Diagram

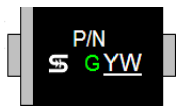

- P/N = Specific Device Code
- G = Green Compound
- YW = Date Code