

### Features

- ◇ UL Recognized File #E-326243
- ◇ For surface mounted application
- ◇ Low power loss, high efficiency
- ◇ High current capability, Low VF
- ◇ High reliability
- ◇ Epitaxial construction
- ◇ Guard-ring for transient protection
- ◇ Green compound with suffix "G" on packing code & prefix "G" on datecode

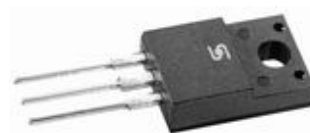

### Mechanical Data

- ◇ Case: ITO-220AB molded plastic
- ◇ Epoxy: UL 94V-0 rate flame retardant
- ◇ Terminals: Pure tin plated, lead solderable per MIL-STD-750, Method 2026 guaranteed
- ◇ Polarity: As marked
- ◇ High temperature soldering guaranteed: 260°C/10s .25"(6.35mm) from case
- ◇ Weight: 1.75 grams
- ◇ Mounting torque: 5 in - 1lbs. Max.

### Ordering Information (example)

Part No.	Package	Packing	Packing code	Green Compound Packing code
SRF1620	ITO-220AB	50 / TUBE	D0	D0G

### Maximum Ratings and Electrical Characteristics

Rating at 25 °C ambient temperature unless otherwise specified.

Single phase, half wave, 60 Hz, resistive or inductive load.

For capacitive load, derate current by 20%

Type Number	Symbol	SRF 1620	SRF 1630	SRF 1640	SRF 1650	SRF 1660	SRF 1690	SRF 1610	SRF 16150	Unit	
Maximum Repetitive Peak Reverse Voltage	$V_{RRM}$	20	30	40	50	60	90	100	150	V	
Maximum RMS Voltage	$V_{RMS}$	14	21	28	35	42	63	70	105	V	
Maximum DC Blocking Voltage	$V_{DC}$	20	30	40	50	60	90	100	150	V	
Maximum Average Forward Rectified Current	$I_{F(AV)}$	16								A	
Peak Forward Surge Current, 8.3 ms Single Half Sine-wave Superimposed on Rated Load (JEDEC method)	$I_{FSM}$	200								A	
Maximum Instantaneous Forward Voltage (Note 1) @ 8A	$V_F$	0.55		0.70		0.90		1.00		V	
Maximum Reverse Current @ Rated VR $T_A=25^\circ\text{C}$ $T_A=100^\circ\text{C}$ $T_A=125^\circ\text{C}$	$I_R$	0.5				0.1				mA	
		15		10		-					
		-				5					
Typical Junction Capacitance (Note 2)	$C_j$	480		300		112				pF	
Typical Thermal Resistance	$R_{\theta JC}$	2.5				4				°C/W	
Operating Temperature Range	$T_J$	- 65 to + 125				- 65 to + 150				°C	
Storage Temperature Range	$T_{STG}$	- 65 to + 150									°C

Note1: Pulse Test with PW=300u sec, 1% Duty cycle

Note2: Measured at 1 MHz and Applied Reverse Voltage of 4.0V D.C.

RATINGS AND CHARACTERISTIC CURVES (SRF1620 THRU SRF16150)

FIG.1 FORWARD CURRENT DERATING CURVE

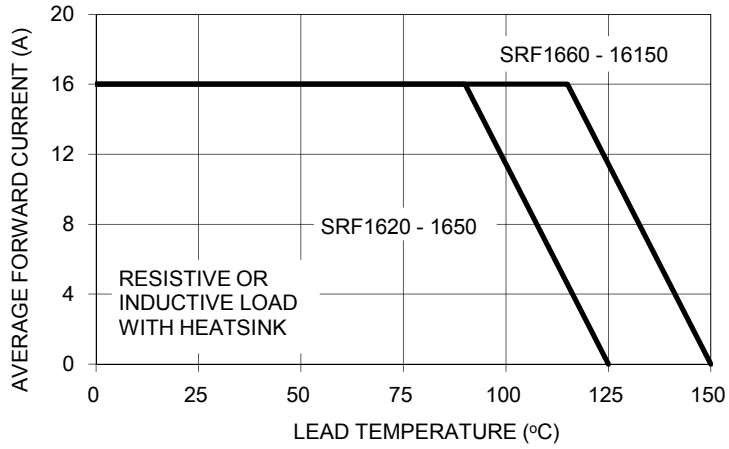

FIG. 2 MAXIMUM NON-REPETITIVE FORWARD SURGE CURRENT

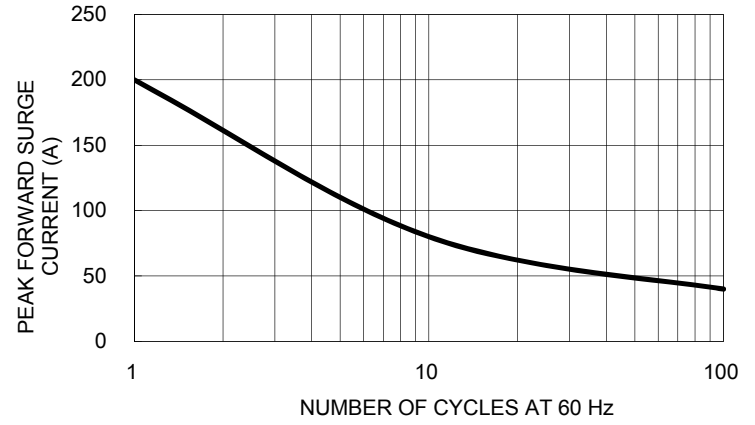

FIG. 3 TYPICAL FORWARD CHARACTERISTICS

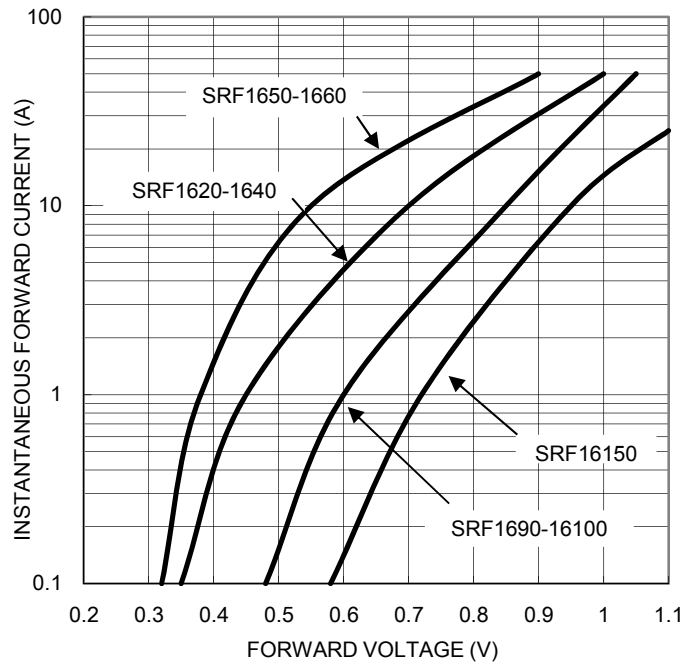

FIG. 4 TYPICAL REVERSE CHARACTERISTICS

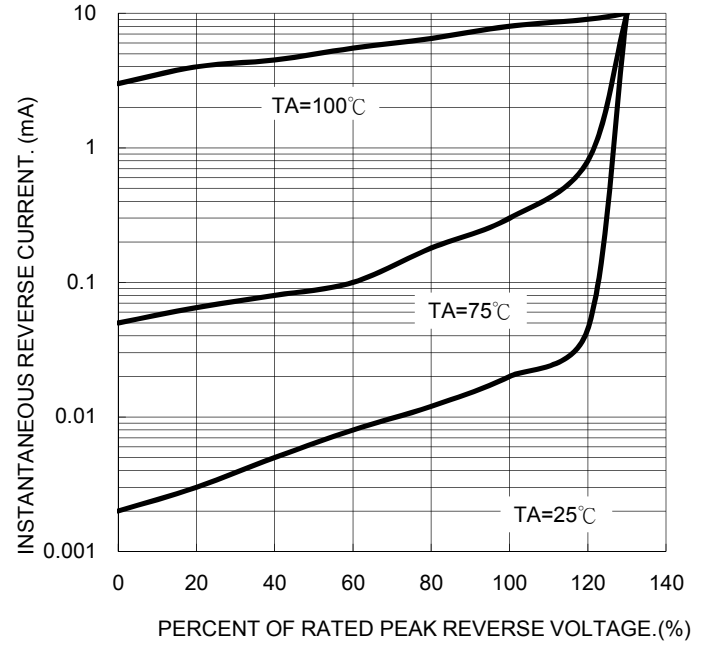

FIG. 5 TYPICAL JUNCTION CAPACITANCE

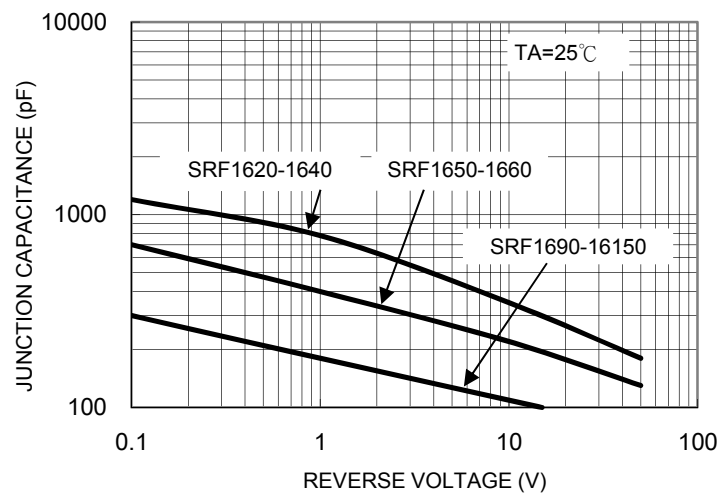
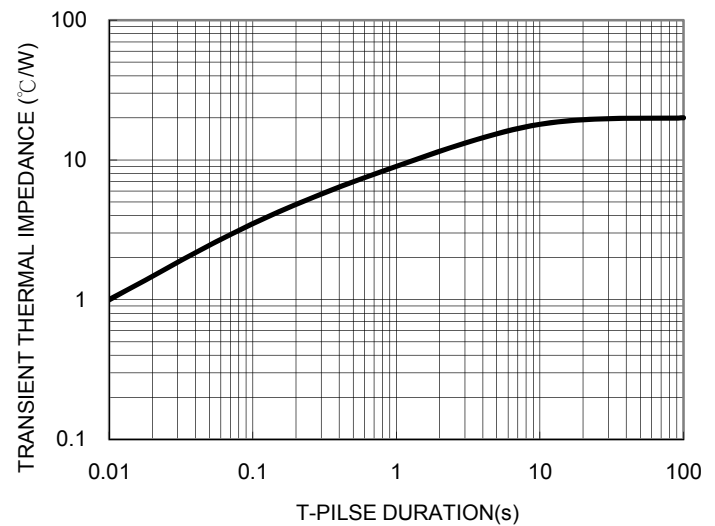

FIG. 6 TYPICAL TRANSIENT THERMAL IMPEDANCE



### Ordering information

Part No.	Package	BULK Packing	Packing code	Green Compound Packing code
SRF16xx	ITO-220AB	50 / TUBE	C0	C0G
	ITO-220AB	50 / TUBE	D0	D0G

Note: "xx" is Device Code from "20" thru "150".

### Dimensions

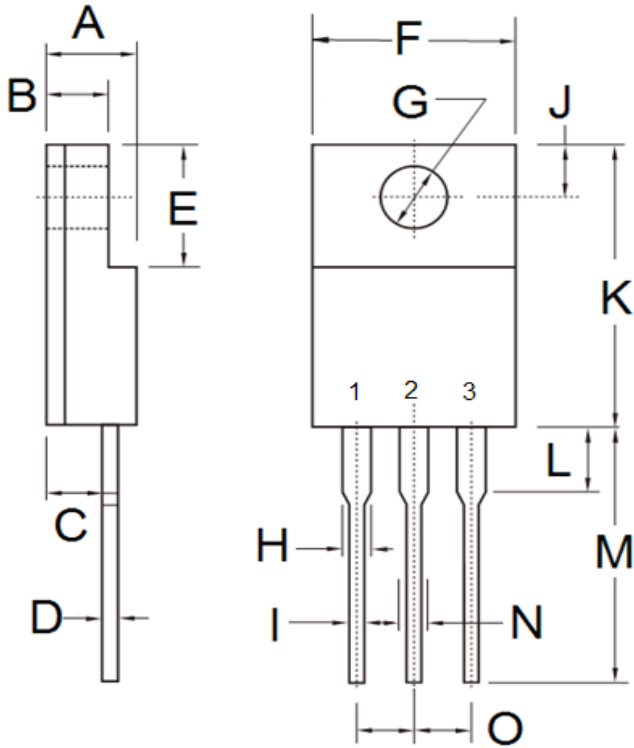

DIM.	Unit(mm)		Unit(inch)	
	Min	Max	Min	Max
A	4.30	4.70	0.169	0.185
B	2.50	3.16	0.098	0.124
C	2.30	2.96	0.091	0.117
D	0.46	0.76	0.018	0.030
E	6.30	6.90	0.248	0.272
F	9.60	10.30	0.378	0.406
G	3.00	3.40	0.118	0.134
H	0.95	1.45	0.037	0.057
I	0.50	0.90	0.020	0.035
J	2.40	3.20	0.094	0.126
K	14.80	15.50	0.583	0.610
L	-	4.10	-	0.161
M	12.60	13.80	0.496	0.543
N	-	1.80	-	0.071
O	2.41	2.67	0.095	0.105

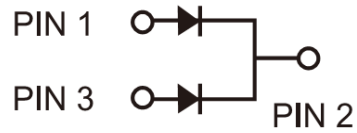

### Marking Diagram



P/N = Specific Device Code  
G = Green Compound  
YWW = Date Code