

### Features

- ✧ UL Recognized File #E-326854
- ✧ For surface mounted application
- ✧ Ideal for automated pick & place
- ✧ Low forward loss, high efficiency
- ✧ High current capability, low VF
- ✧ High reliability
- ✧ Epitaxial construction
- ✧ Guard-ring for transient protection
- ✧ Green compound with suffix "G" on packing code & prefix "G" on datecode



### Mechanical Data

- ✧ Case: D<sup>2</sup>PAK molded plastic
- ✧ Epoxy: UL 94V-0 rate flame retardant
- ✧ Terminals: Pure tin plated, lead free, solderable per MIL-STD-202, Method 208 guaranteed
- ✧ Polarity: As marked
- ✧ High temperature soldering guaranteed: 260°C/10 seconds at terminals
- ✧ Weight: 1.36 grams

### Ordering Information

Part No.	Package	Packing	Packing code	Green Compound Packing code
SRS20xx	D2PAK	800 / 13" REEL	RN	RNG

Note: "x" is Device Code from "20" thru "150".

### Maximum Ratings and Electrical Characteristics

Rating at 25 °C ambient temperature unless otherwise specified.

Single phase, half wave, 60 Hz, resistive or inductive load.

For capacitive load, derate current by 20%

Type Number	Symbol	SRS 2020	SRS 2030	SRS 2040	SRS 2050	SRS 2060	SRS 2090	SRS 20100	SRS 20150	Unit
Maximum Repetitive Peak Reverse Voltage	$V_{RRM}$	20	30	40	50	60	90	100	150	V
Maximum RMS Voltage	$V_{RMS}$	14	21	28	35	42	63	70	105	V
Maximum DC Blocking Voltage	$V_{DC}$	20	30	40	50	60	90	100	150	V
Maximum Average Forward Rectified Current	$I_{F(AV)}$	20								A
Peak Forward Surge Current, 8.3 ms Single Half Sine-wave Superimposed on Rated Load (JEDEC method)	$I_{FSM}$	200								A
Maximum Instantaneous Forward Voltage (Note 1) @10A	$V_F$	0.55		0.70		0.92		1.02		V
Maximum Reverse Current @ Rated VR $T_A=25^\circ\text{C}$ $T_A=100^\circ\text{C}$ $T_A=125^\circ\text{C}$	$I_R$	0.5				0.1				mA
		15		10		-				
		-				5				
Typical Junction Capacitance (Note 2)	$C_j$	600		400		350				pF
Typical Thermal Resistance Per Leg	$R_{\theta JC}$	1.5								°C/W
Operating Temperature Range	$T_J$	- 65 to + 125				- 65 to + 150				°C
Storage Temperature Range	$T_{STG}$	- 65 to + 150								°C

Note 1: Pulse Test with PW=300u sec, 1% Duty Cycle

Note 2: Measured at 1 MHz and Applied Reverse Voltage of 4.0V D.C.

RATINGS AND CHARACTERISTIC CURVES (SRS2020 THRU SRS20150)

FIG.1 FORWARD CURRENT DERATING CURVE

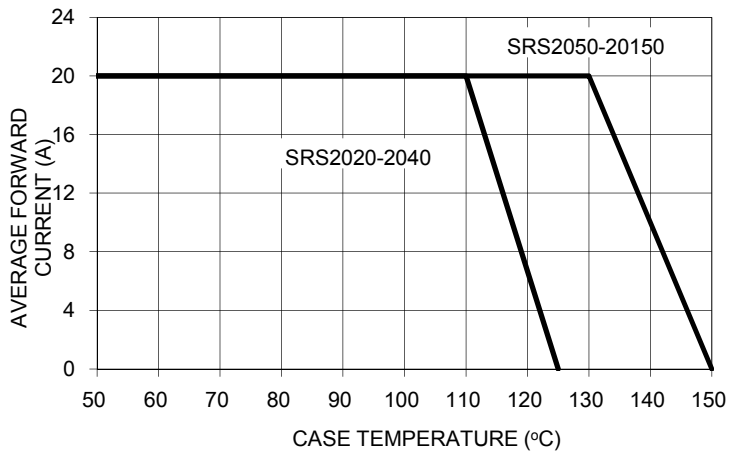

FIG. 2 MAXIMUM NON-REPETITIVE FORWARD SURGE CURRENT PER LEG

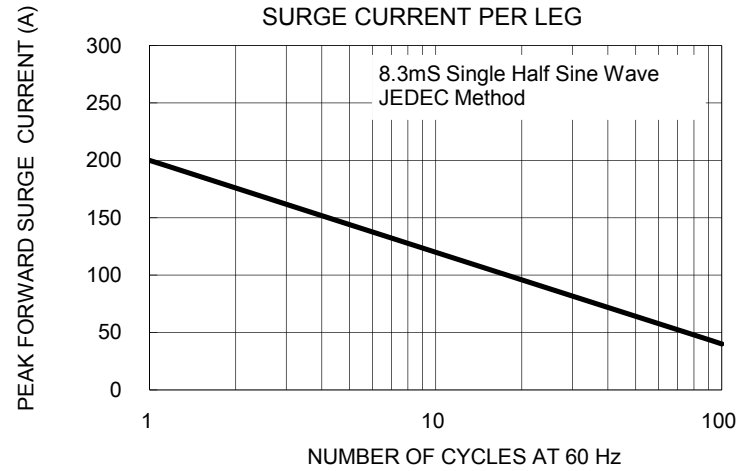

FIG. 3 TYPICAL FORWARD CHARACTERISTICS PER LEG

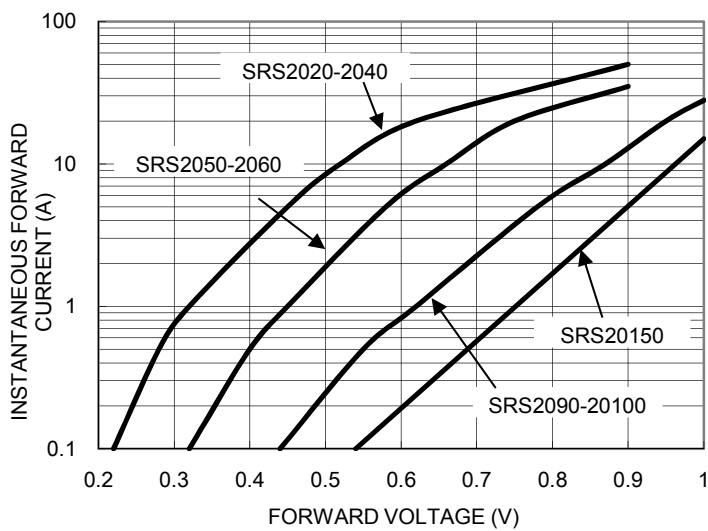

FIG. 4 TYPICAL REVERSE CHARACTERISTICS PER LEG

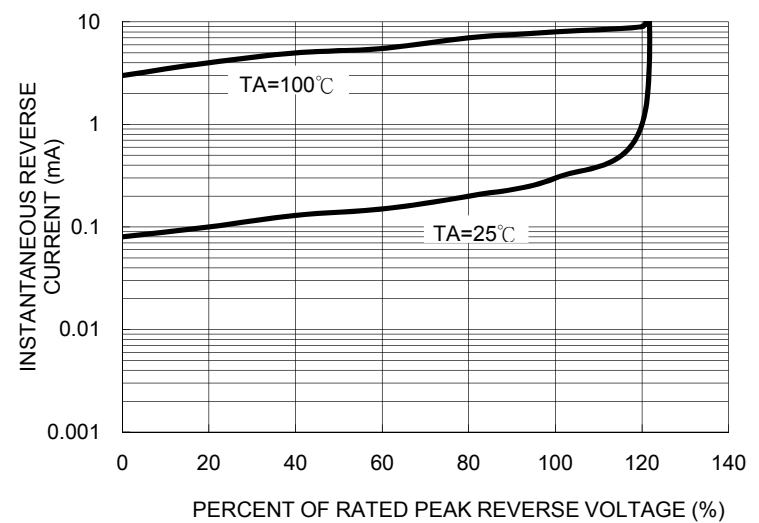

FIG. 5 TYPICAL JUNCTION CAPACITANCE PER LEG

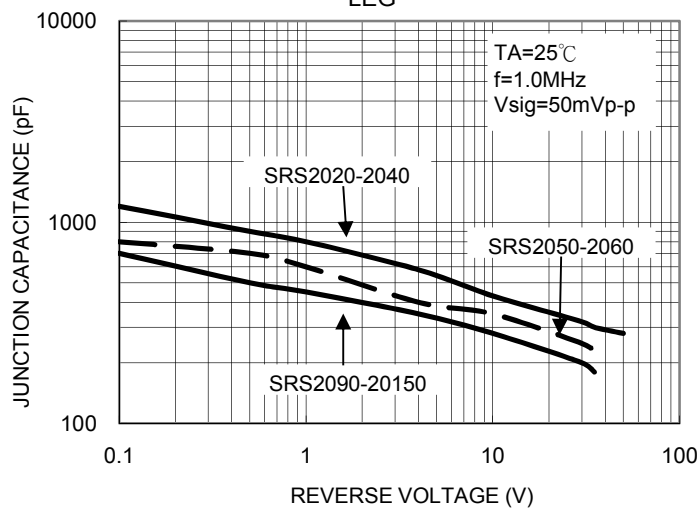
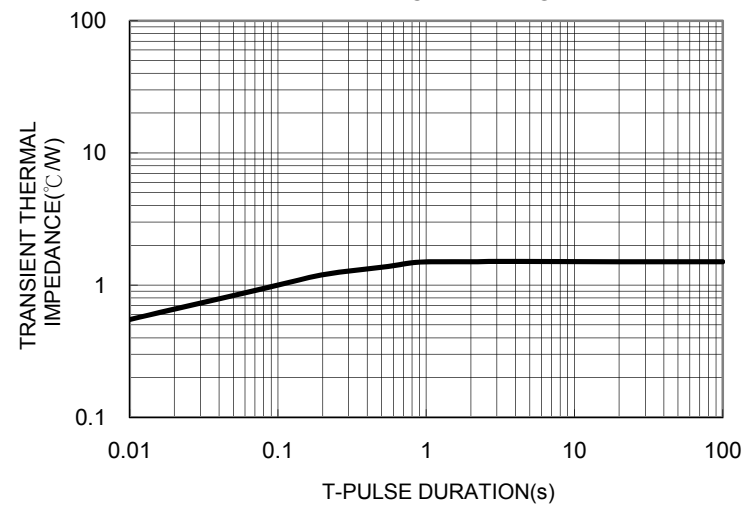
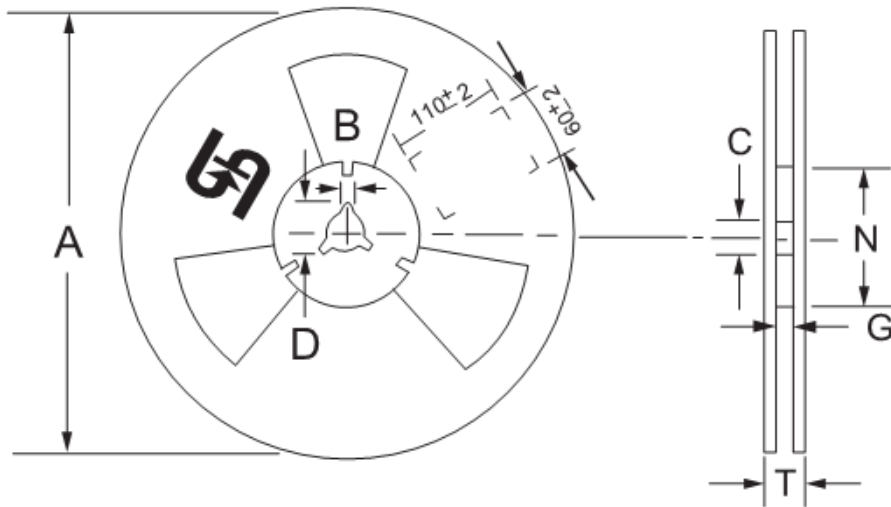
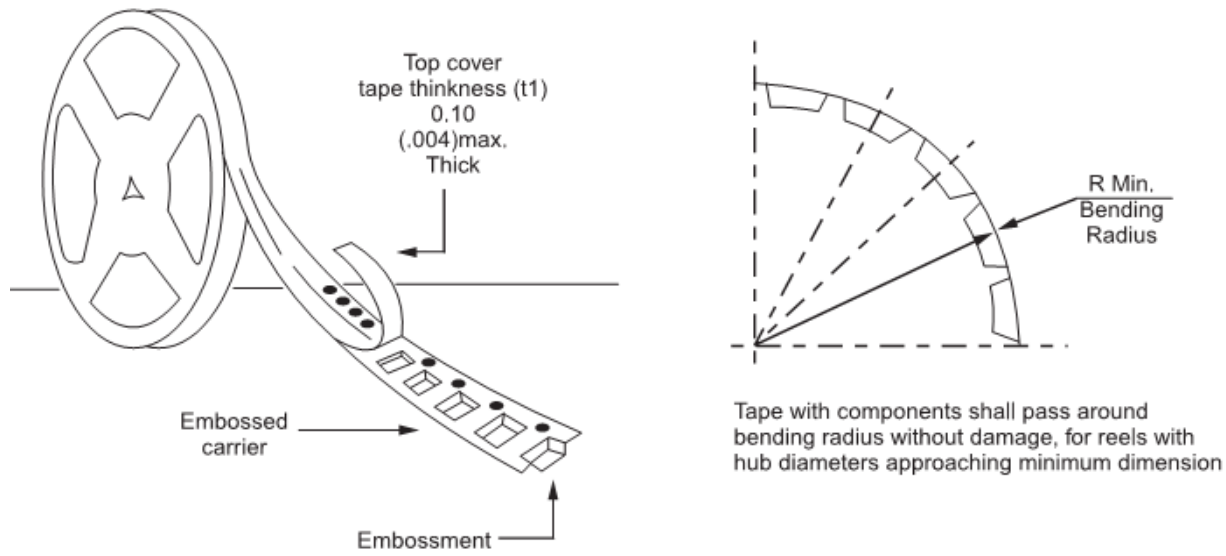

FIG. 6 TYPICAL TRANSIENT THERMAL IMPEDANCE PER LEG



### Tape & Reel specification



Reel Size	Tape Size	A	B	C	D	N	G	T
		max	$\pm 0.5$	$\pm 0.5$	min	$\pm 0.5$	+2.0;-0	max
13"	24mm	330	2	13	20.2	75	24.4	30.4

Unit (mm)

### Suggested PAD Layout

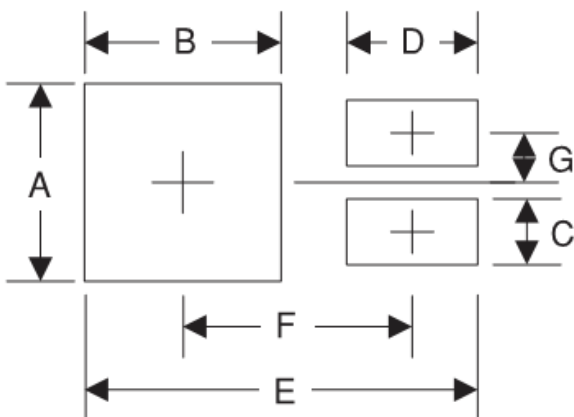

Symbol	Unit(mm)
A	10.8
B	7
C	1.1
D	3.5
E	16.9
F	9.5
G	2.5

### Dimensions

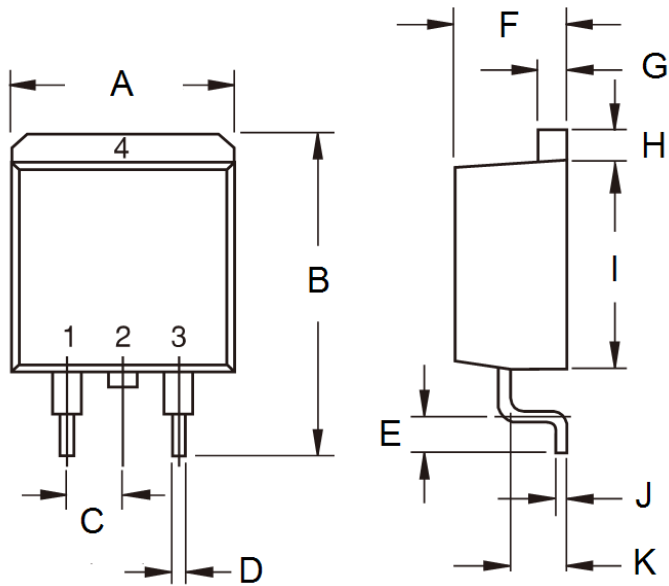

DIM.	Unit(mm)		Unit(inch)	
	Min	Max	Min	Max
A	-	10.5	-	0.413
B	14.60	15.88	0.575	0.625
C	2.41	2.67	0.095	0.105
D	0.68	0.94	0.027	0.037
E	2.29	2.79	0.090	0.110
F	4.44	4.70	0.175	0.185
G	1.14	1.40	0.045	0.055
H	1.14	1.40	0.045	0.055
I	8.25	9.25	0.325	0.364
J	0.36	0.53	0.014	0.021
K	2.03	2.79	0.080	0.110

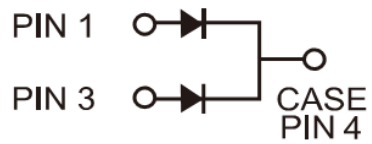

### Marking Diagram



- P/N = Specific Device Code
- G = Green Compound
- YWW = Date Code