

Features

- ✧ For surface mounted application
- ✧ Easy pick and place
- ✧ Metal to silicon rectifier, majority carrier conduction
- ✧ Low power loss, high efficiency
- ✧ High current capability, low VF
- ✧ High surge current capability
- ✧ Plastic material used carriers Underwriters Laboratory Classification 94V-0
- ✧ Epitaxial construction
- ✧ Meet MSL level 1, per J-STD-020D, lead free maximum peak of 260°C
- ✧ High temperature soldering: 260°C/10 seconds at terminals
- ✧ Green compound with suffix "G" on packing code & prefix "G" on datecode



Mechanical Data

- ✧ Case: JEDEC DO-214AB Molded plastic
- ✧ Terminals: Pure tin plated, lead free
- ✧ Polarity: Indicated by cathode band
- ✧ Packaging: 16mm tape per EIA Std RS-481
- ✧ Weight: 0.21 gram

Ordering Information (example)

Part No.	Package	Packing	Packing code	Green Compound Packing code
SS32	SMC	850 / 7" REEL	R7	R7G

Maximum Ratings and Electrical Characteristics

Rating at 25 °C ambient temperature unless otherwise specified.

Single phase, half wave, 60 Hz, resistive or inductive load.

For capacitive load, derate current by 20%

Type Number	Symbol	SS 32	SS 33	SS 34	SS 35	SS 36	SS 39	SS 310	SS 315	SS 320	Unit
Maximum Repetitive Peak Reverse Voltage	V_{RRM}	20	30	40	50	60	90	100	150	200	V
Maximum RMS Voltage	V_{RMS}	14	21	28	35	42	63	70	105	140	V
Maximum DC Blocking Voltage	V_{DC}	20	30	40	50	60	90	100	150	200	V
Maximum Average Forward Rectified Current	$I_{F(AV)}$	3									A
Peak Forward Surge Current, 8.3 ms Single Half Sine-wave Superimposed on Rated Load (JEDEC method)	I_{FSM}	100				70					A
Maximum Instantaneous Forward Voltage (Note 1) @ 3 A $T_A=25^{\circ}C$ $T_A=100^{\circ}C$	V_F	0.5 0.4		0.75 0.65		0.85 0.70		0.95 0.80		V	
Maximum Reverse Current @ Rated VR $T_A=25^{\circ}C$ $T_A=100^{\circ}C$ $T_A=125^{\circ}C$	I_R	0.5					0.1				mA
		10			5		-				
		-					0.5				
Typical Thermal Resistance	$R_{\theta JL}$	17									°C/W
	$R_{\theta JA}$	55									
Operating Temperature Range	T_J	- 55 to + 125				- 55 to + 150					°C
Storage Temperature Range	T_{STG}	- 55 to + 150									°C

Note 1: Pluse Test with PW=300 usec, 1% Duty Cycle

RATINGS AND CHARACTERISTIC CURVES (SS32 THRU SS320)

FIG.1 FORWARD CURRENT DERATING CURVE

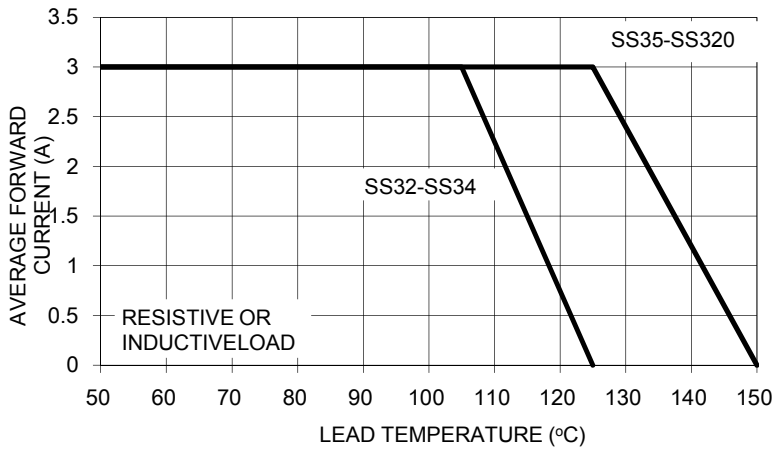

FIG. 2 MAXIMUM NON-REPETITIVE FORWARD SURGE CURRENT

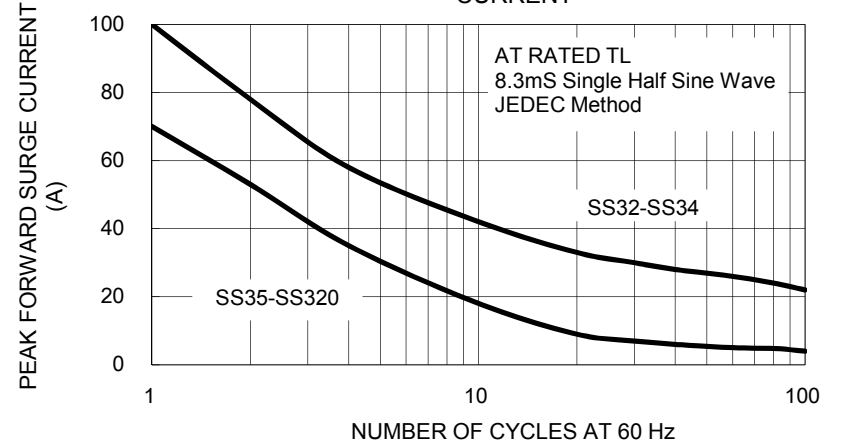

FIG. 3 TYPICAL FORWARD CHARACTERISTICS

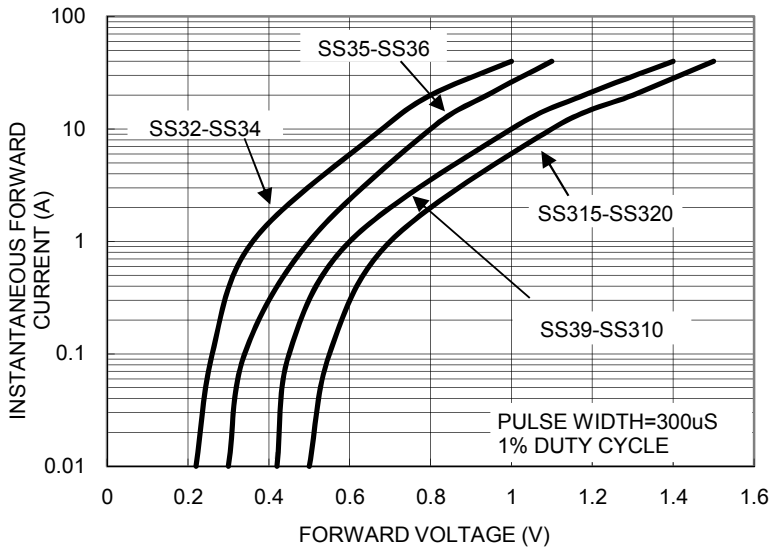

FIG. 4 TYPICAL REVERSE CHARACTERISTICS

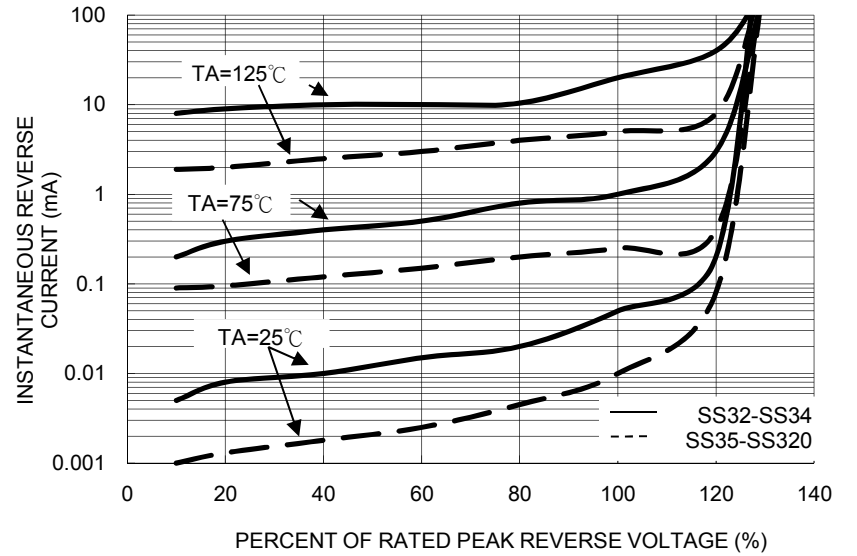

FIG. 5 TYPICAL JUNCTION CAPACITANCE

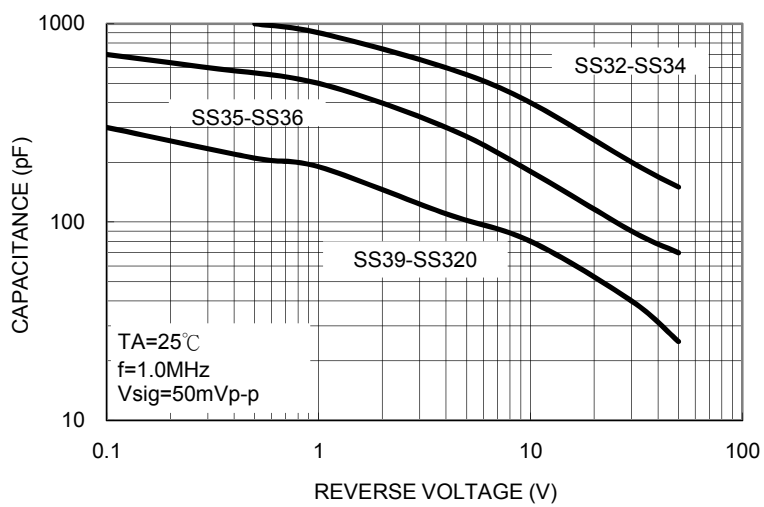
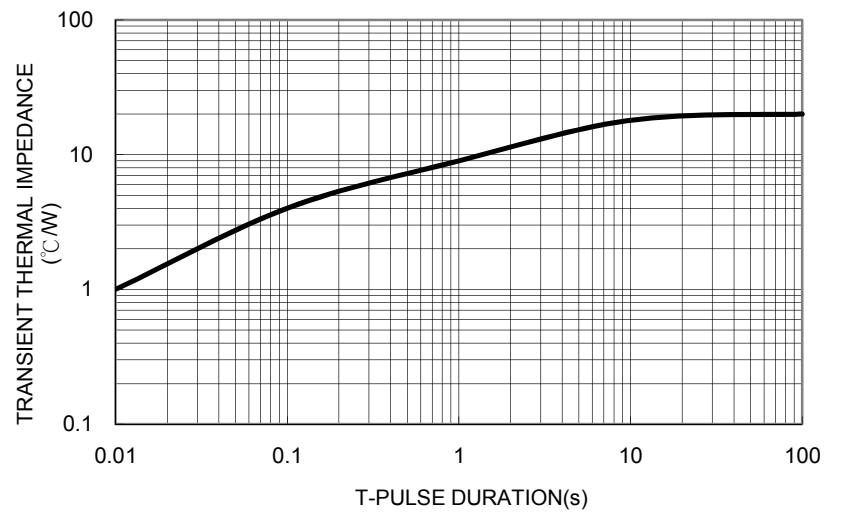

FIG. 6 TYPICAL TRANSIENT THERMAL IMPEDANCE



Ordering information

Part No.	Package	Packing	Packing code	Green Compound Packing code
SS3x (Note)	SMC	850 / 7" REEL	R7	R7G
	SMC	3K / 13" REEL	R6	R6G

Note: "x" is Device Code from "2" thru "20".

Tape & Reel specification

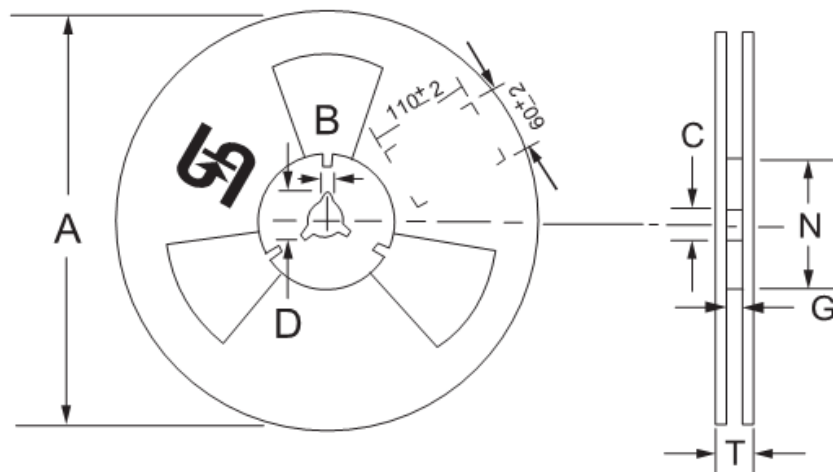
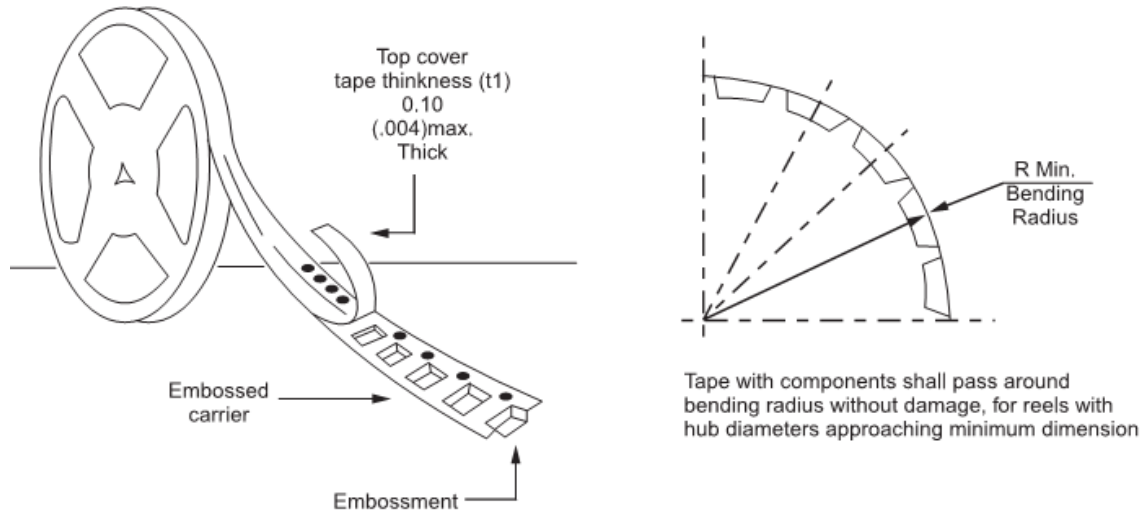

Reel Size	Tape Size	A	B	C	D	N	G	T
		±2.0	±0.4	+0.5;-0.2	min	±1.0	+0.8;-0	max
7"	16mm	178	1.9	13	21	62	16.2	18.6
Reel Size	Tape Size	A	B	C	D	N	G	T
		max	±0.5	±0.5	min	±0.5	+2.0;-0	max
13"	16mm	330	2	13	20.2	75	16.4	22.4

Unit (mm)

Suggested PAD Layout

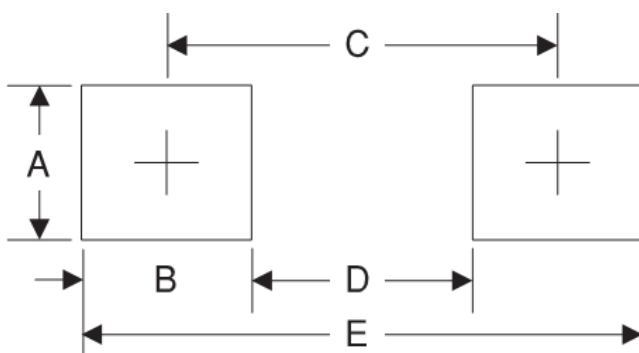

Symbol	Unit(mm)
A	3.3
B	2.5
C	6.8
D	4.4
E	9.3

Dimensions

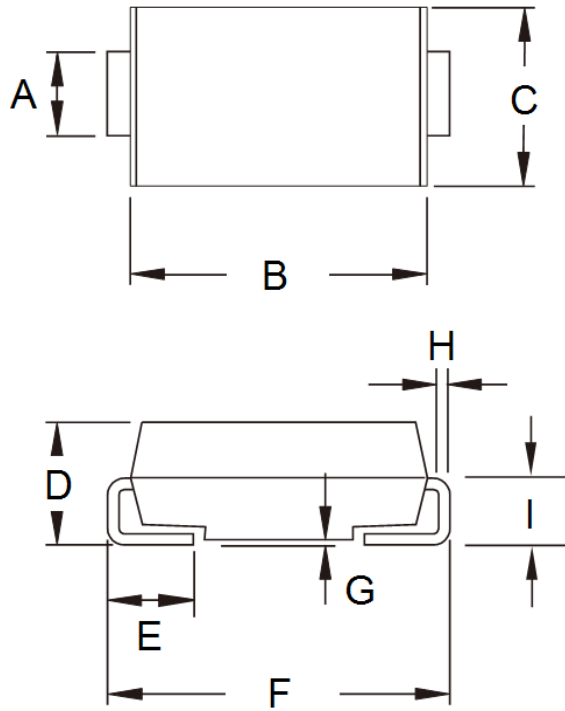

DIM.	Unit(mm)		Unit(inch)	
	Min	Max	Min	Max
A	2.90	3.20	0.114	0.126
B	6.60	7.11	0.260	0.280
C	5.59	6.22	0.220	0.245
D	2.00	2.62	0.079	0.103
E	1.00	1.60	0.039	0.063
F	7.75	8.13	0.305	0.320
G	0.10	0.20	0.004	0.008
H	0.15	0.31	0.006	0.012
I	1.26	1.56	0.050	0.061

Marking Diagram

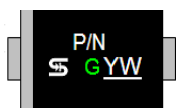

- P/N = Specific Device Code
- G = Green Compound
- YW = Date Code