

### Small Signal Diode

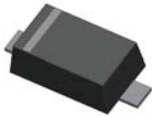

#### Features

- ↪ Surface device type mounting
- ↪ Moisture sensitivity level 1
- ↪ Pb free version and RoHS compliant
- ↪ Green compound (Halogen free) with suffix "G" on packing code and prefix "G" on date code

#### Mechanical Data

- ↪ Case : Flat lead SOD-123F small outline plastic package
- ↪ Terminal: Matte tin plated, lead free., solderable per MIL-STD-202, Method 208 guaranteed
- ↪ High temperature soldering guaranteed: 260°C/10s
- ↪ Polarity : Indicated by cathode band
- ↪ Weight : 8.85±0.5 mg

#### Ordering Information

Part No.	Package	Packing Code	Packing	Marking
B0520LWF	SOD-123F	RH	3K / 7" Reel	SD
B0530WF	SOD-123F	RH	3K / 7" Reel	SE
B0540WF	SOD-123F	RH	3K / 7" Reel	SQ
B0520LWF	SOD-123F	RHG	3K / 7" Reel	SD
B0530WF	SOD-123F	RHG	3K / 7" Reel	SE
B0540WF	SOD-123F	RHG	3K / 7" Reel	SQ

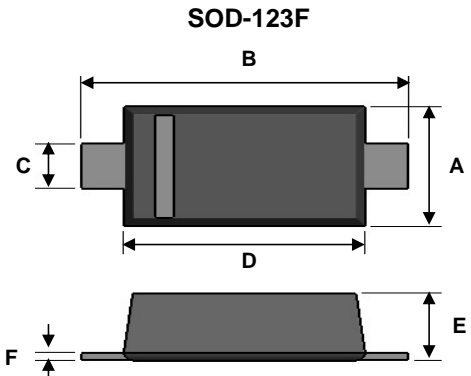

Dimensions	Unit (mm)		Unit (inch)	
	Min	Max	Min	Max
A	1.50	1.70	0.059	0.067
B	3.30	3.90	0.130	0.154
C	0.50	0.70	0.020	0.028
D	2.50	2.70	0.098	0.106
E	0.80	1.15	0.031	0.045
F	0.05	0.20	0.002	0.008

#### Pin Configuration



#### Suggested PAD Layout

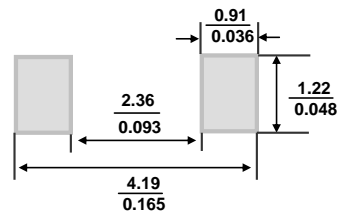

#### Maximum Ratings and Electrical Characteristics

Rating at 25°C ambient temperature unless otherwise specified.

#### Maximum Ratings

Type Number	Symbol	B0520LWF	B0530WF	B0540WF	Units
Repetitive Peak Reverse Voltage	V <sub>RRM</sub>	20	30	40	V
Reverse Voltage	V <sub>R</sub>	20	30	40	
Average Forward Current @ TL=100°C (Lead Temperature)	I <sub>o</sub>	500			mA
Non-Repetitive Peak Forward Surge Current (Note 1)	I <sub>FSM</sub>	5.5			A
Thermal Resistance (Junction to Lead)	R <sub>θJL</sub>	150	150	118	°C/W
Thermal Resistance (Junction to Ambient)	R <sub>θJA</sub>	340	206	206	°C/W
Operating Junction Temperature	T <sub>J</sub>	125		150	°C
Storage Temperature Range	T <sub>STG</sub>	-65 to + 125		-65 to + 150	°C

- Notes: 1. Device mounted on FR-4 PCB 0.013 mm.  
 2. 1 inch pad size ( 1 x 0.5 inch for each lead ) on FR4 board.  
 3. The suggested land pattern dimensions have been provided for reference only, as actual pad layouts may vary depending on application.

### Small Signal Diode

### Maximum Ratings Electrical Characteristics

Rating at 25°C ambient temperature unless otherwise specified.

Type Number	Symbol	B0520LWF	B0530WF	B0540WF	Units
Forward Voltage IF= 0.1 A IF= 0.5 A IF= 1.0 A IF= 0.1 A, Ta = 100°C IF= 0.5 A, Ta = 100°C IF= 1.0 A, Ta = 100°C	VF	0.300	0.375	-	V
		0.385	0.5	0.51	
		-	-	0.62	
		0.220	-	-	
		0.330	-	0.46	
		-	-	0.61	
Reverse Leakage Current VR = 10V VR = 20V VR = 10V, Ta = 100°C VR = 20V, Ta = 100°C VR = 15V VR = 30V VR = 40V VR = 40V, Ta = 100°C	IR	75	-	-	μA
		250	-	10	mA
		5	-	-	
	8	-	5	μA	
	-	20	-		
	-	130	-		
	-	-	20	mA	
	-	-	13		

### Carrier & Reel specification

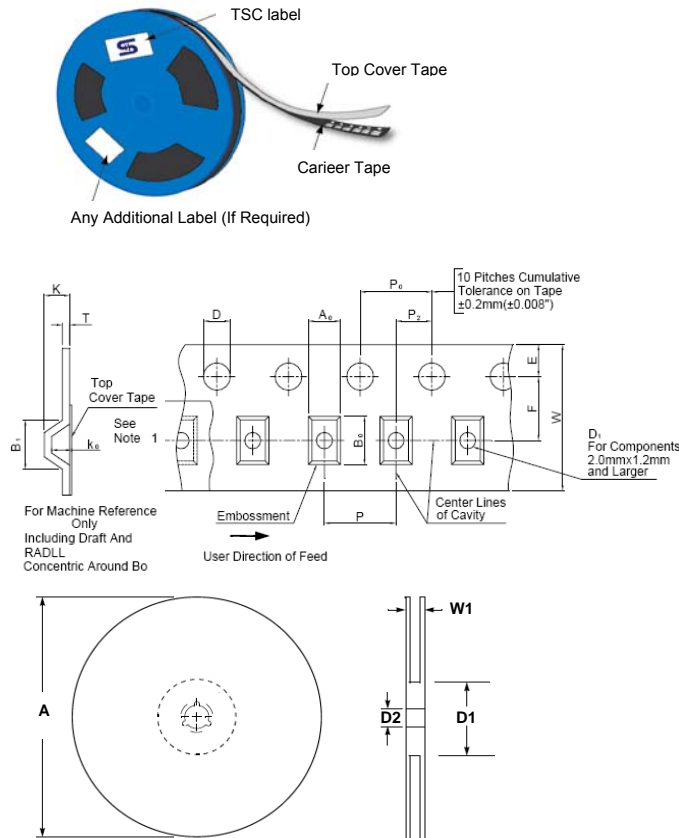

Item	Symbol	Dimension(mm)
Carrier depth	K	2.40 Max.
Sprocket hole	D	1.50 +0.10
Reel outside diameter	A	178 ± 1
Reel inner diameter	D1	50 Min.
Feed hole width	D2	13.0 ± 0.5
Sprocket hole position	E	1.75 ±0.10
Punch hole position	F	3.50 ±0.05
Sprocket hole pitch	P0	4.00 ±0.10
Embossment center	P1	2.00 ±0.10
Overall tape thickness	T	0.6 Max.
Tape width	W	8.30 Max.
Reel width	W1	14.4 Max.

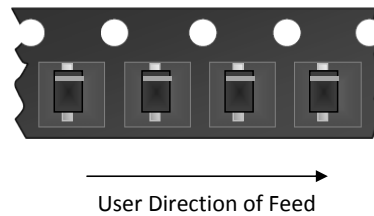

Note 1: A0, B0, and K0 are determined by component size. The clearance between the components and the cavity must be within 0.05 mm min. to 0.5 mm max. The component cannot rotate more than 10° within the determined cavity.

Note 2: If B1 exceeds 4.2 mm(0.165") for 8 mm embossed tape, the tape may not feed through all tape feeders.

**Small Signal Diode**

**Rating and Characteristic Curves**

**FIG. 1 Typical Forward Characteristics**

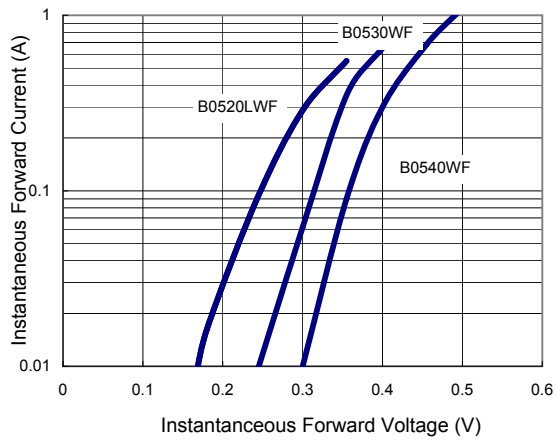

**FIG. 2 Forward Current Derating Curve**

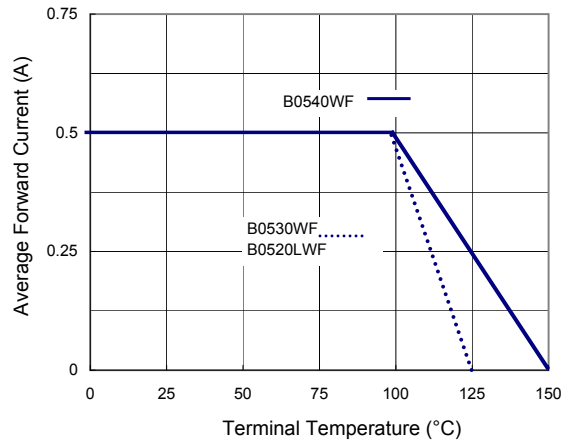

**FIG. 3 Typical Junction Capacitance**

