

### General Description

This planar stripe MOSFET has better characteristics, such as fast switching time, low on resistance, low gate charge and excellent avalanche characteristics. It is mainly suitable for switching mode power supplies.

### FEATURES

- $V_{DSS} = 600V$ ,  $I_D = 1.9A$
- Drain-Source ON Resistance :  
 $R_{DS(ON)} = 5.0$  @  $V_{GS} = 10V$
- $Q_g(\text{typ.}) = 10.9nC$

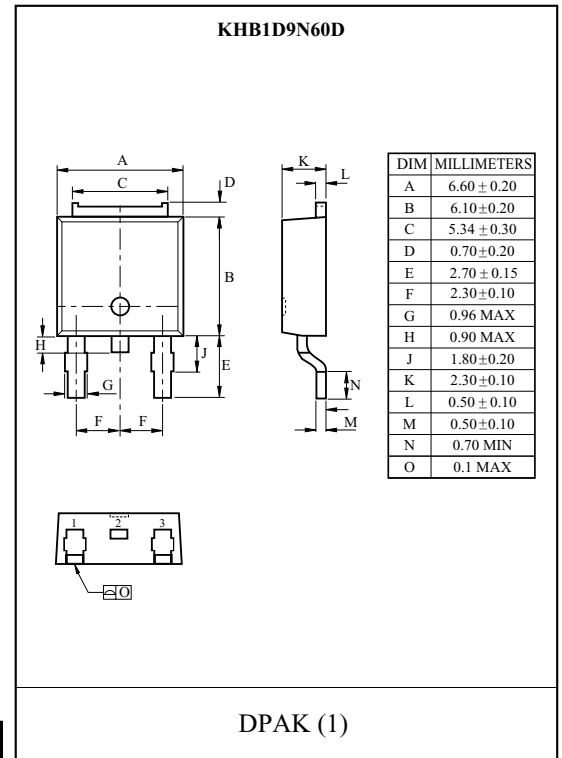

### MAXIMUM RATING (Tc=25 )

CHARACTERISTIC	SYMBOL	RATING		UNIT
		KHB1D9N60D	KHB1D9N60I	
Drain-Source Voltage	$V_{DSS}$	600		V
Gate-Source Voltage	$V_{GSS}$	± 30		V
Drain Current	@ $T_C=25$	1.9	1.9*	A
	@ $T_C=100$	1.1	1.1	
	Pulsed (Note1)	$I_{DP}$	7.6	
Single Pulsed Avalanche Energy (Note 2)	$E_{AS}$	120		mJ
Repetitive Avalanche Energy (Note 1)	$E_{AR}$	4.4		mJ
Peak Diode Recovery dv/dt (Note 3)	dv/dt	4.5		V/ns
Drain Power Dissipation	$T_C=25$	44	28	W
	Derate above 25	0.35	0.22	W/
Maximum Junction Temperature	$T_j$	150		
Storage Temperature Range	$T_{stg}$	-55 150		
<b>Thermal Characteristics</b>				
Thermal Resistance, Junction-to-Case	$R_{thJC}$	2.79	2.79	/W
Thermal Resistance, Case-to-Sink	$R_{thCS}$	50	50	/W
Thermal Resistance, Junction-to-Ambient	$R_{thJA}$	110	110	/W

\* : Drain current limited by maximum junction temperature.

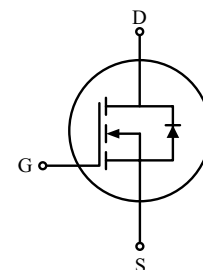
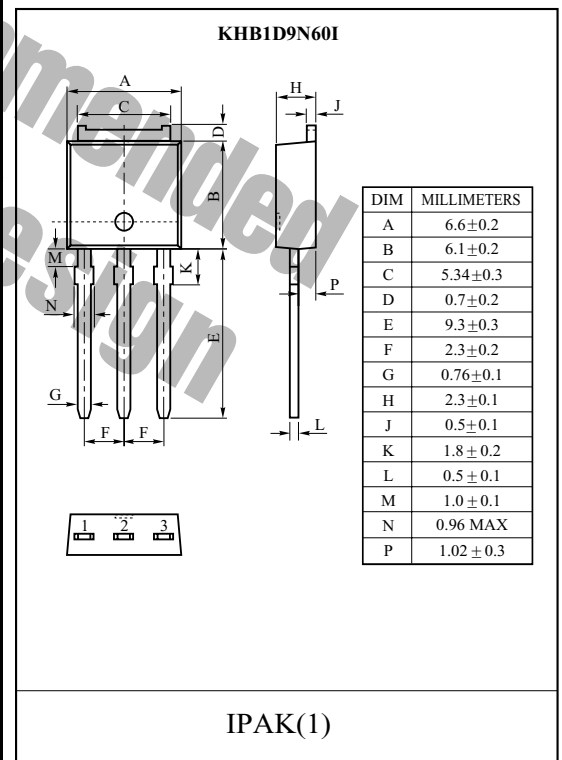

# KHB1D9N60D/I

## ELECTRICAL CHARACTERISTICS (Tc=25 )

CHARACTERISTIC	SYMBOL	TEST CONDITION	MIN.	TYP.	MAX.	UNIT
<b>Static</b>						
Drain-Source Breakdown Voltage	$BV_{DSS}$	$I_D=250\ \mu A, V_{GS}=0V$	600	-	-	V
Breakdown Voltage Temperature Coefficient	$BV_{DSS}/T_j$	$I_D=250\ \mu A$ , Referenced to 25	-	0.65	-	V/
Drain Cut-off Current	$I_{DSS}$	$V_{DS}=600V, V_{GS}=0V$ ,	-	-	10	$\mu A$
Gate Threshold Voltage	$V_{th}$	$V_{DS}=V_{GS}, I_D=250\ \mu A$	2.0	-	4.0	V
Gate Leakage Current	$I_{GSS}$	$V_{GS}=\pm 30V, V_{DS}=0V$	-	-	$\pm 100$	nA
Drain-Source ON Resistance	$R_{DS(ON)}$	$V_{GS}=10V, I_D=0.95A$	-	3.8	5.0	
<b>Dynamic</b>						
Total Gate Charge	$Q_g$	$V_{DS}=480V, I_D=1.9A$ $V_{GS}=10V$ (Note4,5)	-	10.9	12	nC
Gate-Source Charge	$Q_{gs}$		-	1.7	3	
Gate-Drain Charge	$Q_{gd}$		-	5.0	5.5	
Turn-on Delay time	$t_{d(on)}$	$V_{DD}=300V$ $R_L=158$ $R_G=25$ (Note4,5)	-	-	28	ns
Turn-on Rise time	$t_r$		-	-	60	
Turn-off Delay time	$t_{d(off)}$		-	-	58	
Turn-off Fall time	$t_f$		-	-	66	
Input Capacitance	$C_{iss}$	$V_{DS}=25V, V_{GS}=0V, f=1.0MHz$	-	388	504	pF
Reverse Transfer Capacitance	$C_{rss}$		-	6.5	8.5	
Output Capacitance	$C_{oss}$		-	45.7	59.4	
<b>Source-Drain Diode Ratings</b>						
Continuous Source Current	$I_S$	$V_{GS}<V_{th}$	-	-	1.9	A
Pulsed Source Current	$I_{SP}$		-	-	7.6	
Diode Forward Voltage	$V_{SD}$	$I_S=1.9A, V_{GS}=0V$	-	-	1.5	V
Reverse Recovery Time	$t_{rr}$	$I_S=1.9A, V_{GS}=0V$ ,	-	300	-	ns
Reverse Recovery Charge	$Q_{rr}$	$dI_S/dt=100A/\mu s$	-	1.55	-	$\mu C$

Note 1) Repetivity rating : Pulse width limited by junction temperature.

Note 2)  $L = 36.9mH, I_S=1.9A, V_{DD}=50V, R_G = 25$  , Starting  $T_j=25$  .

Note 3)  $I_S = 1.9A, dI/dt = 100A/\mu s, V_{DD} = BV_{DSS}$ , Starting  $T_j=25$  .

Note 4) Pulse Test : Pulse width  $300\mu s$ , Duty Cycle  $2\%$ .

Note 5) Essentially independent of operating temperature.

# KHB1D9N60D/I

$I_D - V_{DS}$

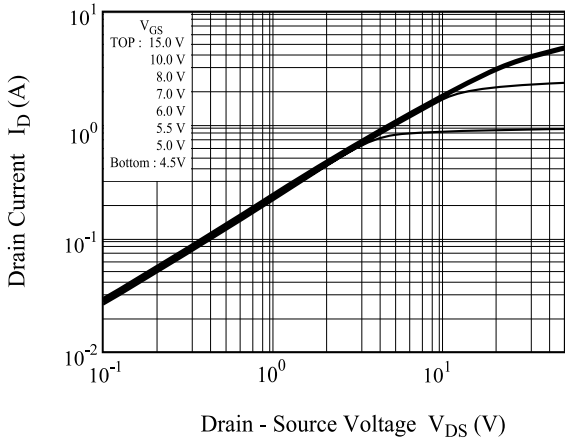

$I_D - V_{GS}$

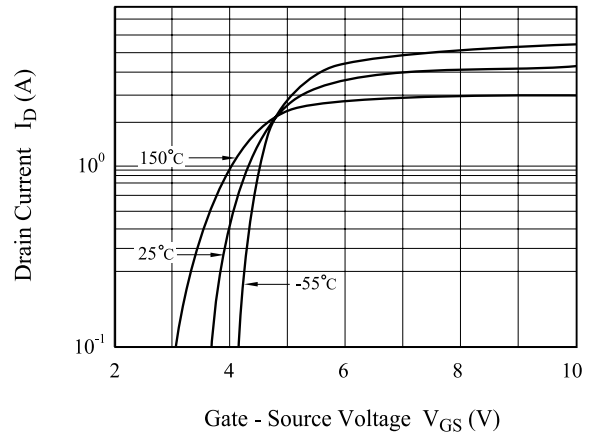

$BV_{DSS} - T_j$

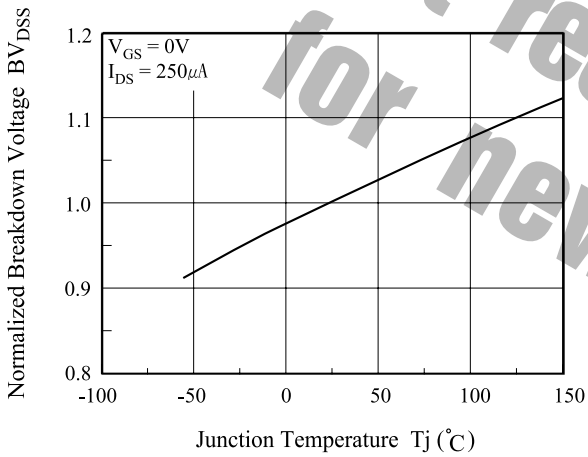

$R_{DS(ON)} - I_D$

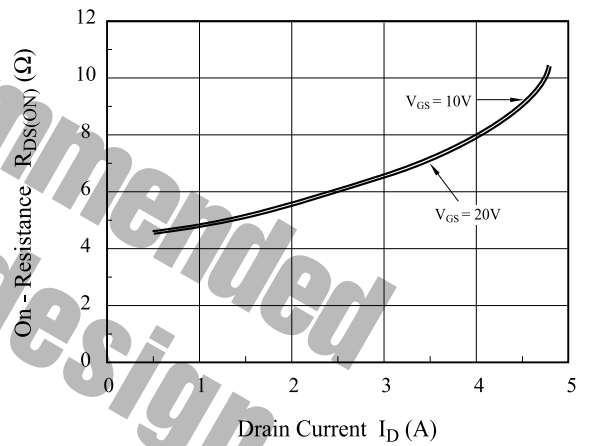

$I_S - V_{SD}$

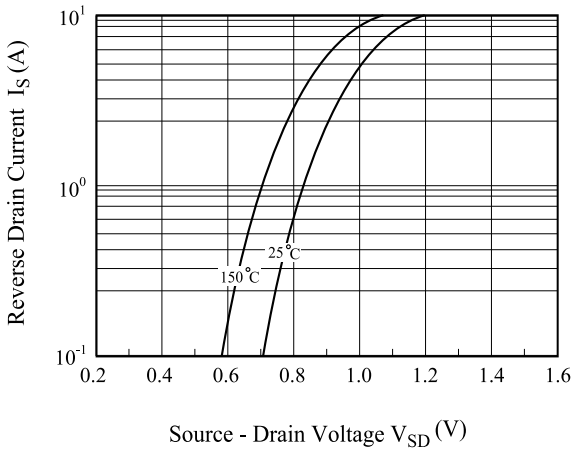

$R_{DS(ON)} - T_j$

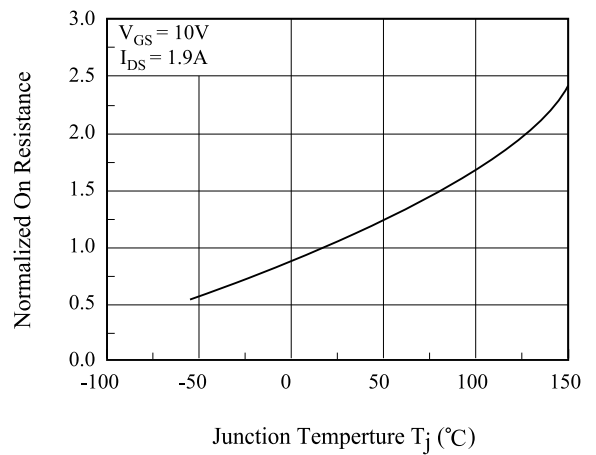

# KHB1D9N60D/I

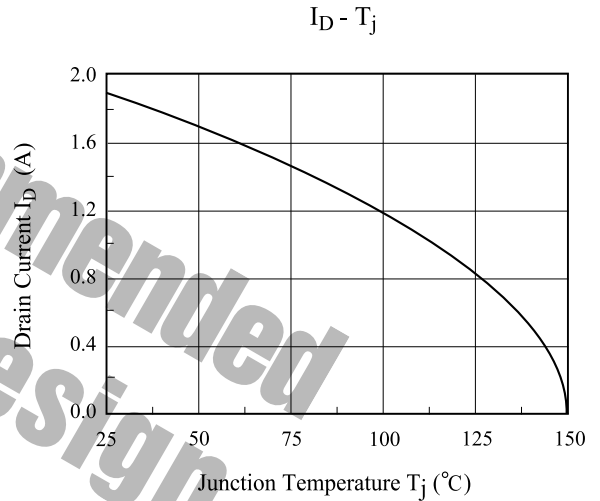
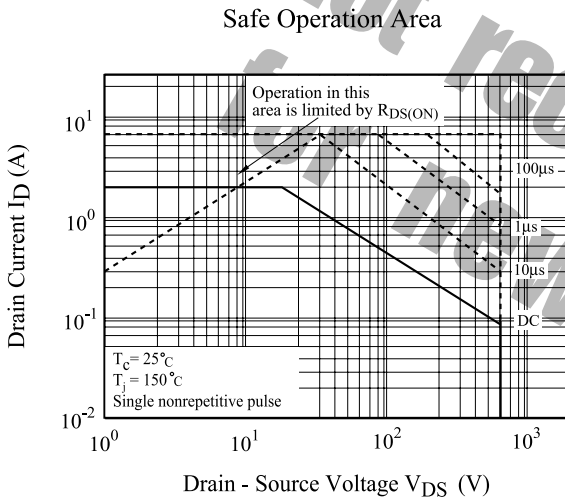
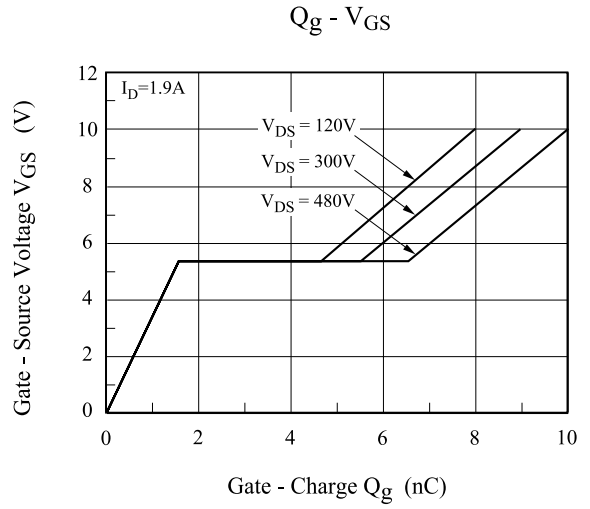
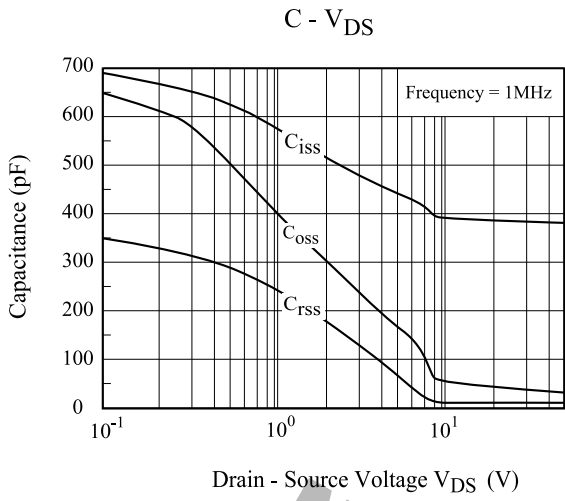

## R<sub>th</sub>

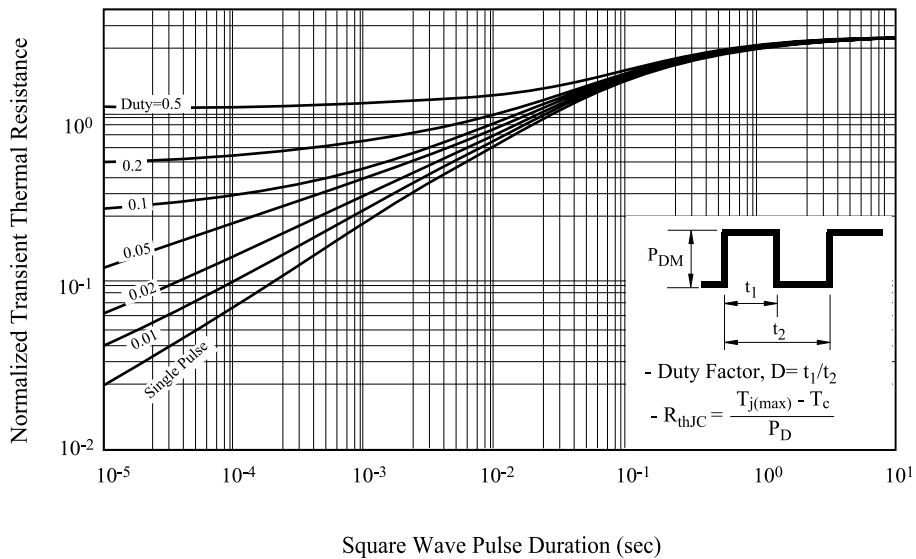

# KHB1D9N60D/I

## - Gate Charge

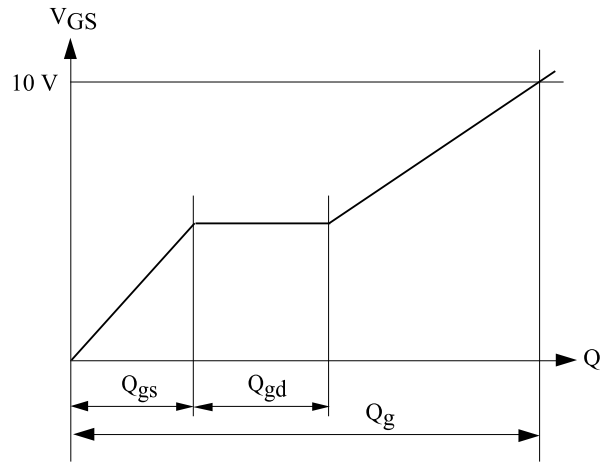
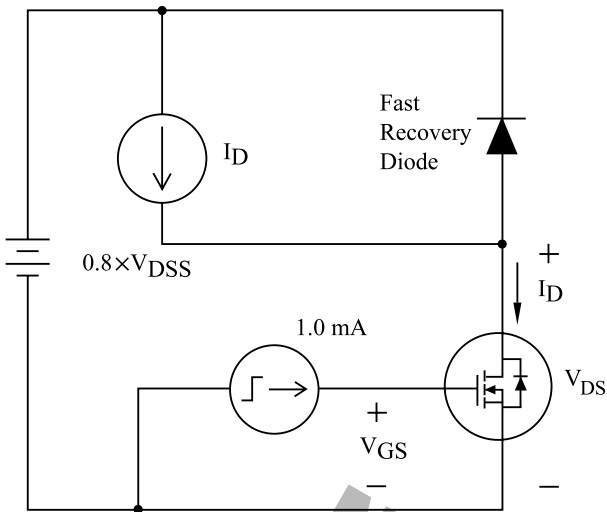

## - Single Pulsed Avalanche Energy

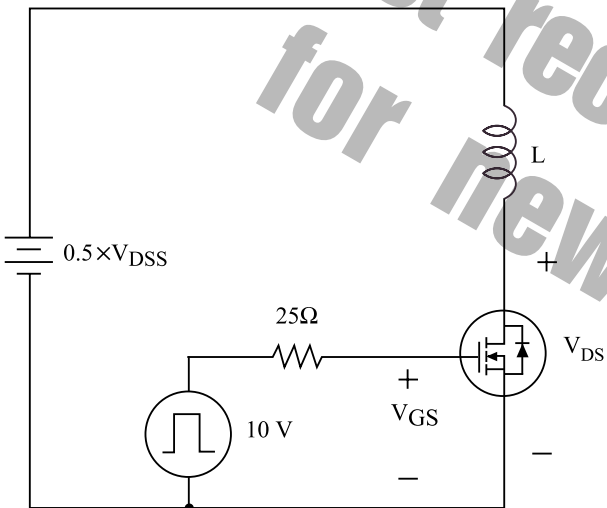

$$E_{AS} = \frac{1}{2} L I_{AS}^2 \frac{BV_{DSS}}{BV_{DSS} - V_{DD}}$$

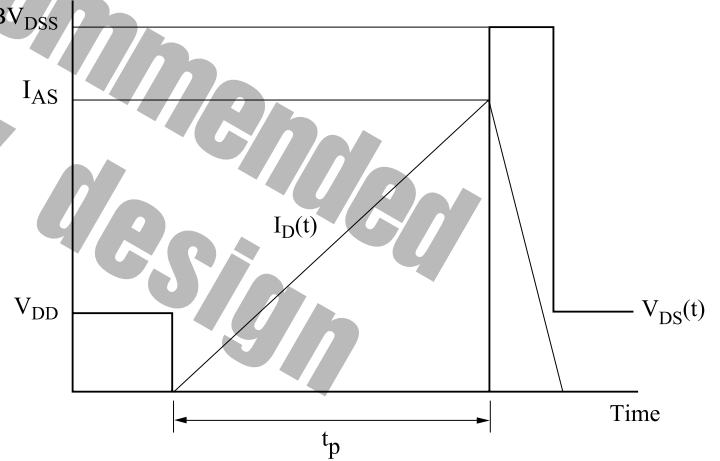

## - Resistive Load Switching

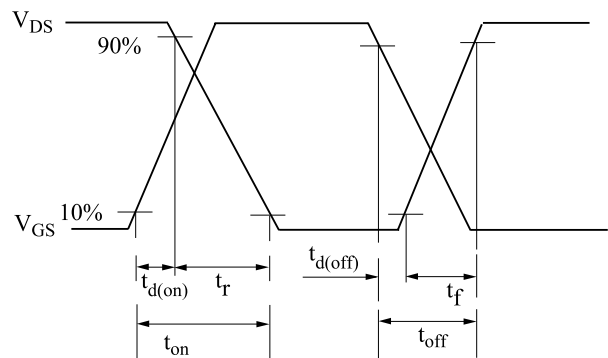
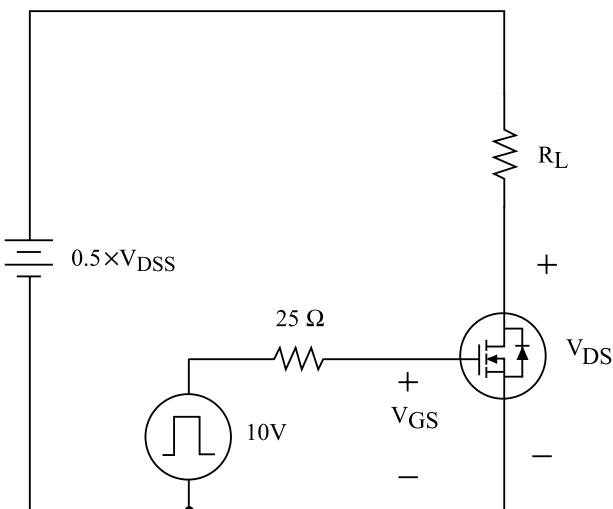

# KHB1D9N60D/I

- Source - Drain Diode Reverse Recovery and  $dv/dt$

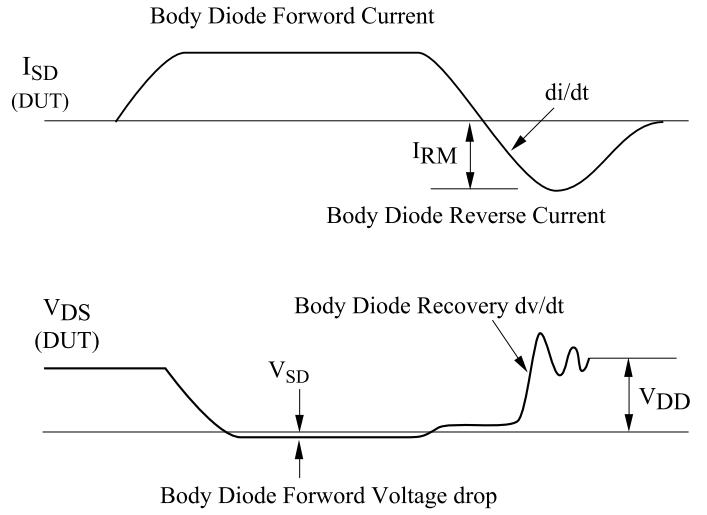
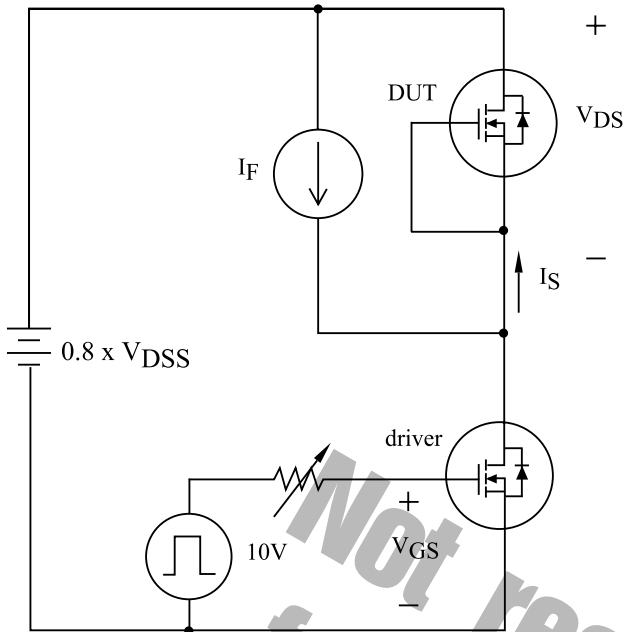

Not recommended for new design