

RF Switching for VCR/DVD/Set Top Box Tuner

FEATURES

- Low loss at on state(Typ 1dB@1GHz)
- With built-in bias diode

FET Maximum Ratings (Ta=25 °C)

CHARACTERISTIC	SYMBOL	RATING	UNIT
Drain-Source-Voltage	V_{DS}	± 3	V
Drain-Gate-Voltage	V_{DG}	7	V
Source-Gate-Voltage	V_{SG}	7	V
Drain Current	I_D	10	mA

DIODE Maximum Ratings (Ta=25 °C)

CHARACTERISTIC	SYMBOL	RATING	UNIT
Reverse Voltage	V_R	35	V
Forward Current	I_F	100	mA

FET DIODE Maximum Ratings (Ta=25 °C)

CHARACTERISTIC	SYMBOL	RATING	UNIT
Power Dissipation	P_C	200	mW
Junction Temperature	T_j	150	°C
Storage Temperature Range	T_{stg}	-55~150	°C

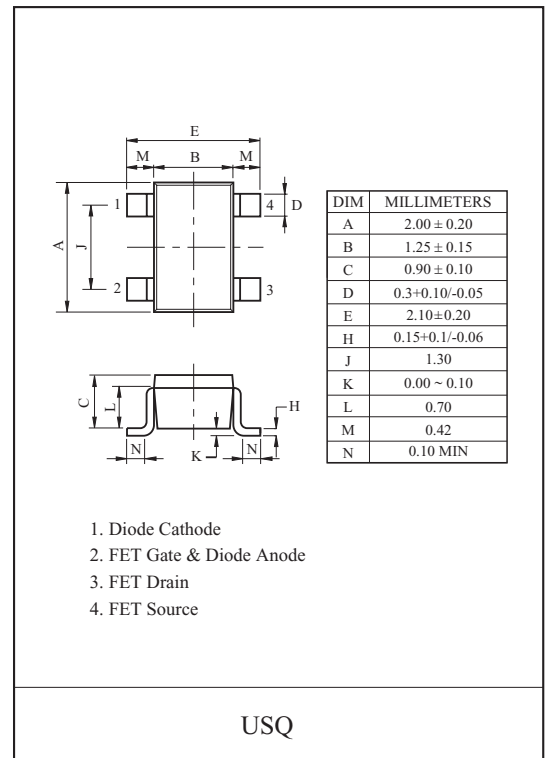

EQUIVALENT CIRCUIT

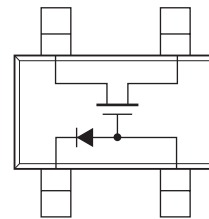

Marking

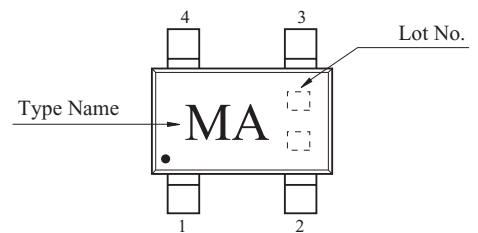

KTK920U

FET ELECTRICAL CHARACTERISTICS (Ta=25 °C)

CHARACTERISTIC	SYMBOL	TEST CONDITIONS	MIN	TYP	MAX	UNIT
Gate-Source Breakdown Voltage	$V_{(BR)GSS}$	$V_{DS}=0, I_{GS}=-0.1mA$	7	-	-	V
Gate-Source Pinch-off Voltage	$V_{GS(OFF)}$	$V_{DS}=1V, I_D=20\mu A$	-	-3	-4	V
Drain-Source Leakage Current	I_{DSX}	$V_{DS}=2V, V_{GS}=-5V$	-	-	10	μA
Gate Cut-off Current	I_{GSS}	$V_{DS}=0, V_{GS}=-5V$	-	-	-100	nA
Drain-Source On-State Resistance	$R_{DS(ON)}$	$V_{GS}=0, I_D=1mA$	-	12	20	Ω
Loss(On-State)	$ S_{21(ON)} ^2$	$V_{SC}=V_{DC}=0, R_S=R_L=50\Omega, I_F=0, f\leq 1GHz$	-	-	2	dB
		$V_{SC}=V_{DC}=0, R_S=R_L=50\Omega, I_F=0, f=1GHz$	-	1.3	-	dB
		$V_{SC}=V_{DC}=0, R_S=R_L=75\Omega, I_F=0, f\leq 1GHz$	-	-	3	dB
Isolation (Off-State)	$ S_{21(OFF)} ^2$	$V_{SC}=V_{DC}=5V, R_S=R_L=50\Omega, I_F=1mA, f\leq 1GHz$	30	-	-	dB
		$V_{SC}=V_{DC}=5V, R_S=R_L=50\Omega, I_F=1mA, f=1GHz$	-	38	-	dB
		$V_{SC}=V_{DC}=5V, R_S=R_L=75\Omega, I_F=1mA, f\leq 1GHz$	30	-	-	dB
Input Capacitance ^{Note1}	C_{ic}	$V_{SC}=V_{DC}=5V, I_F=1mA, f=1MHz$	-	1	-	pF
		$V_{SC}=V_{DC}=0, I_F=0, f=1MHz$	-	0.65	-	pF
Output Capacitance ^{Note1}	C_{oc}	$V_{SC}=V_{DC}=5V, I_F=1mA, f=1MHz$	-	1	-	pF
		$V_{SC}=V_{DC}=0, I_F=0, f=1MHz$	-	0.65	-	pF

Note : 1 C_{ic} is the series connection of C_{sg} and C_{gc} ;
 C_{oc} is the series connection of C_{dg} and C_{gc} ;

DIODE ELECTRICAL CHARACTERISTICS (Ta=25 °C)

CHARACTERISTIC	SYMBOL	TEST CONDITIONS	MIN	TYP	MAX	UNIT
Forward Voltage	V_F	$I_F=2mA$	-	-	0.85	V
Reverse Current	I_R	$V_R=15V$	-	-	0.1	μA
Reverse Voltage	V_R	$I_R=1\mu A$	35	-	-	V
Total Capacitance	C_T	$V_R=6V, f=1MHz$	-	0.7	1.2	pF
Series Resistance	r_S	$I_F=2mA, f=100MHz$	-	0.5	0.9	Ω

Fig. $|S_{21(on)}|^2$ $|S_{21(off)}|^2$ Test Circuit

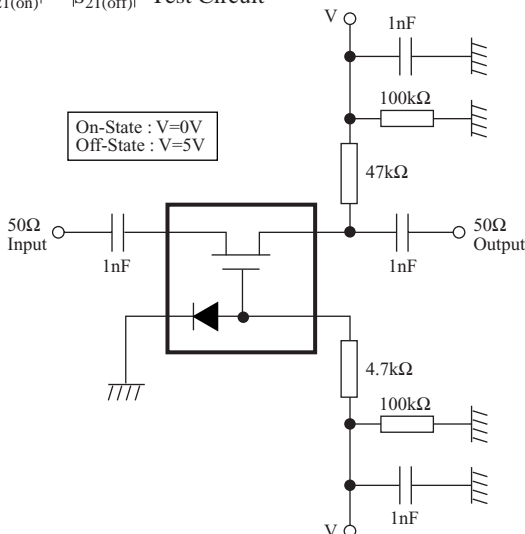

KTK920U

