

General Description

This planar stripe MOSFET has better characteristics, such as fast switching time, low on resistance, low gate charge and excellent avalanche characteristics. It is mainly suitable for LED Lighting and switching mode power supplies.

FEATURES

- $V_{DSS(Min.)} = 400V$, $I_D = 2.2A$
- Drain-Source ON Resistance : $R_{DS(ON)} = 3.4$ (max) @ $V_{GS} = 10V$
- $Q_g(\text{typ.}) = 4.4nC$

MAXIMUM RATING (Tc=25)

CHARACTERISTIC	SYMBOL	RATING	UNIT
Drain-Source Voltage	V_{DSS}	400	V
Gate-Source Voltage	V_{GSS}	± 30	V
Drain Current	@ $T_C=25$	I_D	2.2
	@ $T_C=100$		1.4
	Pulsed (Note1)	I_{DP}	6*
Single Pulsed Avalanche Energy (Note 2)	E_{AS}	52	mJ
Repetitive Avalanche Energy (Note 1)	E_{AR}	3	mJ
Peak Diode Recovery dv/dt (Note 3)	dv/dt	4.5	V/ns
Drain Power Dissipation	$T_C=25$	P_D	40
	Derate above 25		0.32
Maximum Junction Temperature	T_j	150	
Storage Temperature Range	T_{stg}	-55 150	
Thermal Characteristics			
Thermal Resistance, Junction-to-Case	R_{thJC}	3.1	/W
Thermal Resistance, Junction-to-Ambient	R_{thJA}	110	/W

* : Drain current limited by maximum junction temperature.

PIN CONNECTION

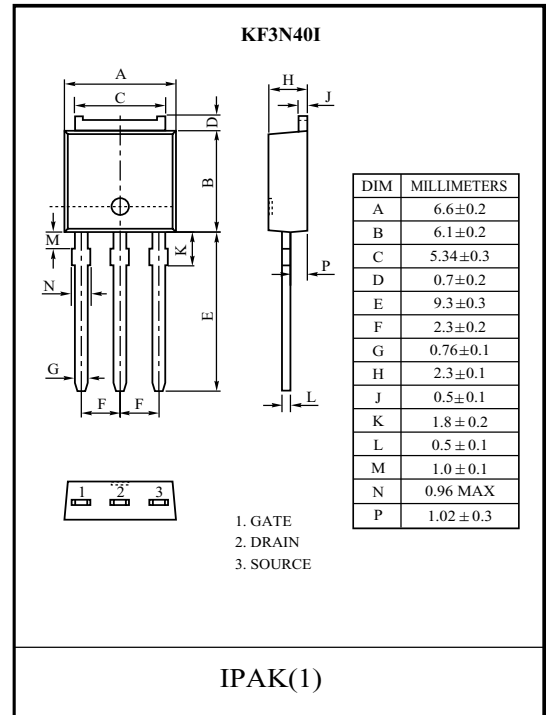
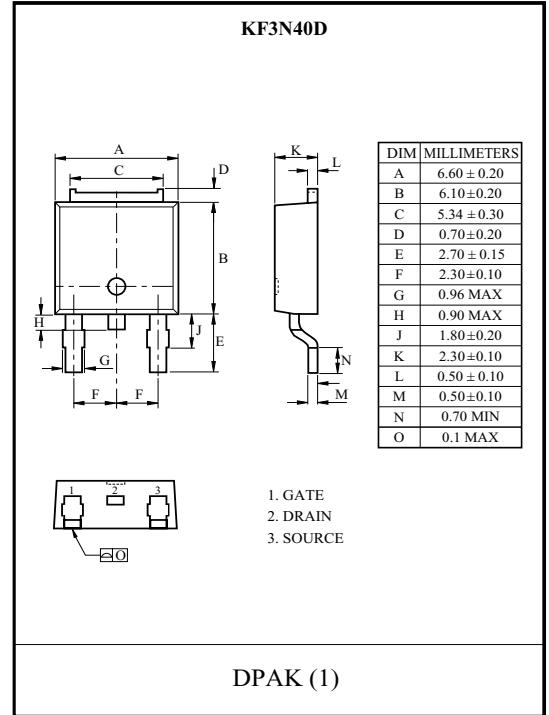
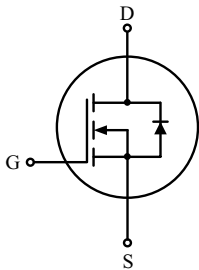

KF3N40D/I

ELECTRICAL CHARACTERISTICS (T_c=25 °C)

CHARACTERISTIC	SYMBOL	TEST CONDITION	MIN.	TYP.	MAX.	UNIT
Static						
Drain-Source Breakdown Voltage	BV _{DSS}	I _D =250 μA, V _{GS} =0V	400	-	-	V
Breakdown Voltage Temperature Coefficient	BV _{DSS} / T _j	I _D =250 μA, Referenced to 25	-	0.4	-	V/°C
Drain Cut-off Current	I _{DSS}	V _{DS} =400V, V _{GS} =0V,	-	-	10	μA
Gate Threshold Voltage	V _{th}	V _{DS} =V _{GS} , I _D =250 μA	2.5	-	4.5	V
Gate Leakage Current	I _{GSS}	V _{GS} = ± 30V, V _{DS} =0V	-	-	± 100	nA
Drain-Source ON Resistance	R _{DS(ON)}	V _{GS} =10V, I _D =1.1A	-	2.8	3.4	Ω
Dynamic						
Total Gate Charge	Q _g	V _{DS} =320V, I _D =2.2A V _{GS} =10V (Note4,5)	-	4.4	5.8	nC
Gate-Source Charge	Q _{gs}		-	1.0	-	
Gate-Drain Charge	Q _{gd}		-	2.0	-	
Turn-on Delay time	t _{d(on)}	V _{DD} =200V, I _D =2.2A R _G =25 (Note4,5) V _{GS} =10V	-	10	-	ns
Turn-on Rise time	t _r		-	11	-	
Turn-off Delay time	t _{d(off)}		-	20	-	
Turn-off Fall time	t _f		-	17	-	
Input Capacitance	C _{iss}	V _{DS} =25V, V _{GS} =0V, f=1.0MHz	-	163	211	pF
Output Capacitance	C _{oss}		-	26	-	
Reverse Transfer Capacitance	C _{rss}		-	2.5	-	
Source-Drain Diode Ratings						
Continuous Source Current	I _S	V _{GS} <V _{th}	-	-	2	A
Pulsed Source Current	I _{SP}		-	-	8	
Diode Forward Voltage	V _{SD}	I _S =2.2A, V _{GS} =0V	-	-	1.4	V
Reverse Recovery Time	t _{rr}	I _S =2.2A, V _{GS} =0V, dI _S /dt=100A/μs	-	240	-	ns
Reverse Recovery Charge	Q _{rr}		-	0.65	-	μC

Note 1) Repetivity rating : Pulse width limited by junction temperature.

Note 2) L = 19mH, I_S=2.2A, V_{DD}=50V, R_G = 25 Ω, Starting T_j = 25 °C.

Note 3) I_S = 2A, dI/dt = 200A/μs, V_{DD} = BV_{DSS}, Starting T_j = 25 °C.

Note 4) Pulse Test : Pulse width = 300μs, Duty Cycle = 2%.

Note 5) Essentially independent of operating temperature.

Marking

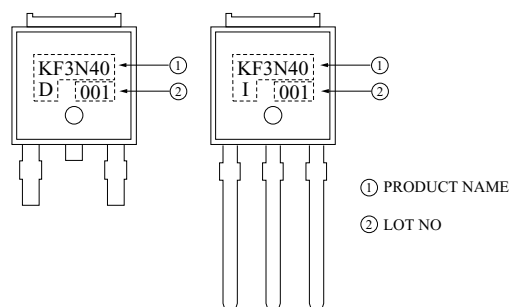

KF3N40D/I

Fig1. $I_D - V_{DS}$

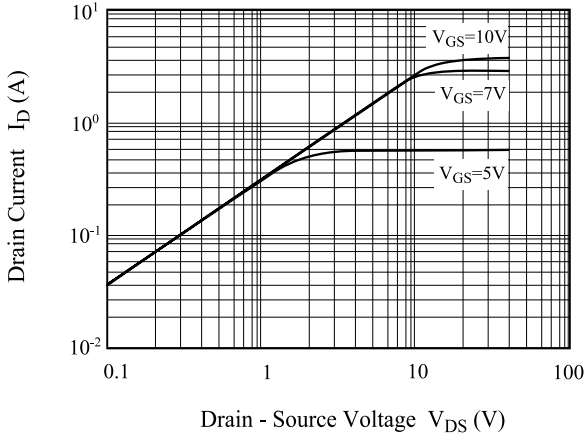

Fig2. $I_D - V_{GS}$

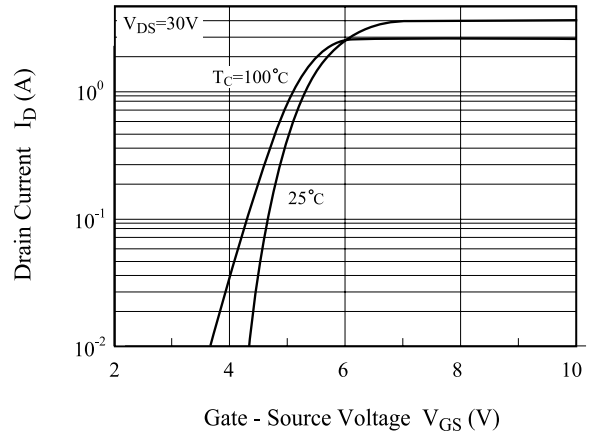

Fig3. $BV_{DSS} - T_j$

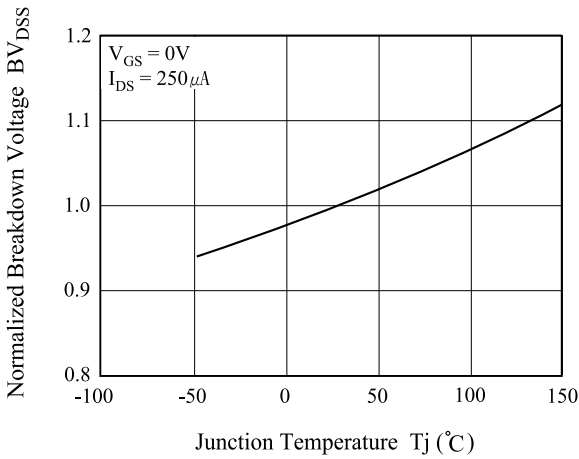

Fig4. $R_{DS(ON)} - I_D$

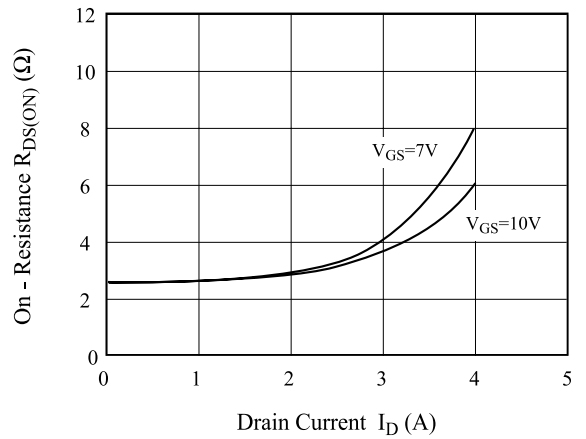

Fig5. $I_S - V_{SD}$

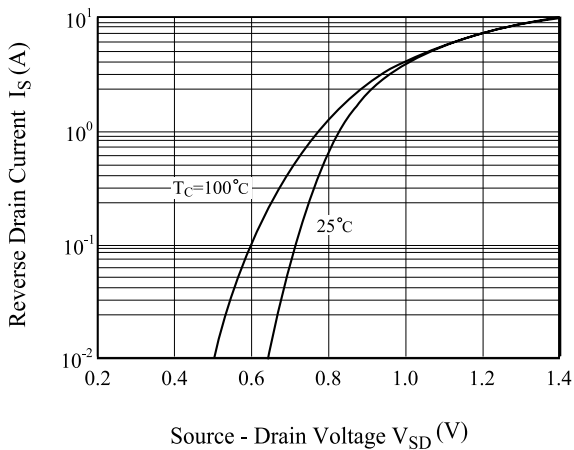
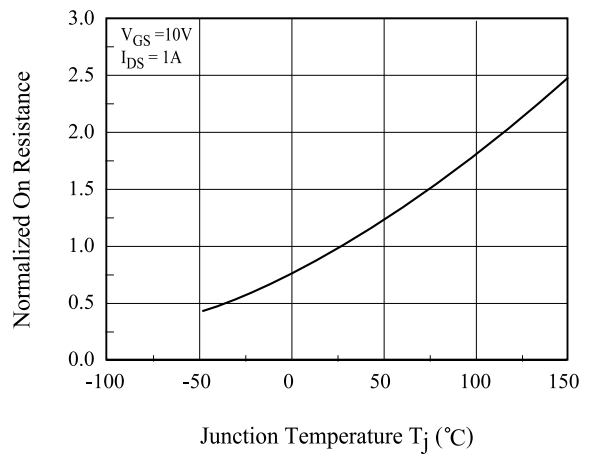

Fig6. $R_{DS(ON)} - T_j$



KF3N40D/I

Fig 7. C - V_{DS}

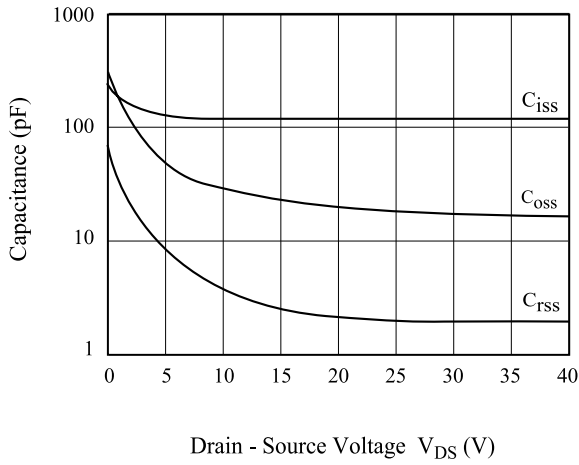

Fig8. Q_g- V_{GS}

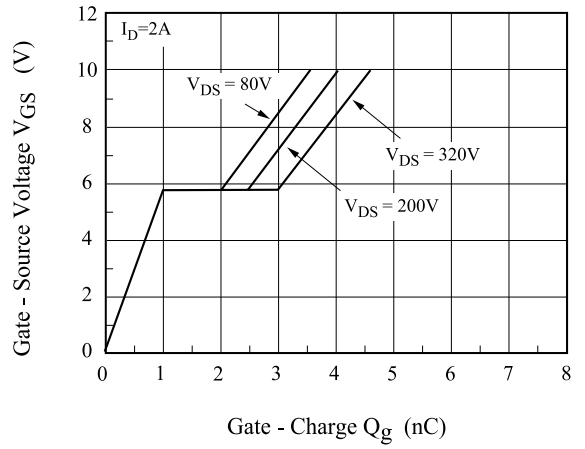

Fig9. Safe Operation Area

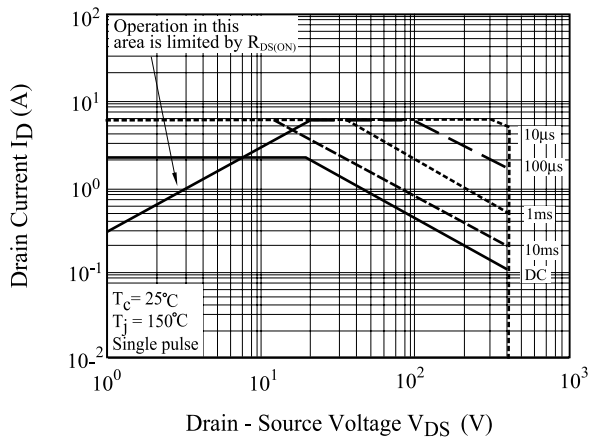

Fig10. I_D - T_j

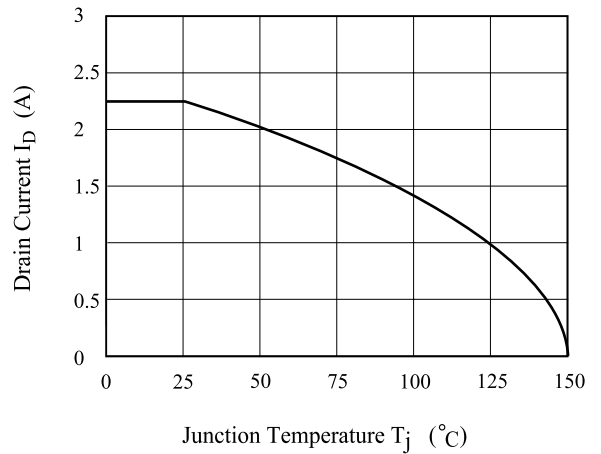

Fig11. Transient Thermal Response Curve

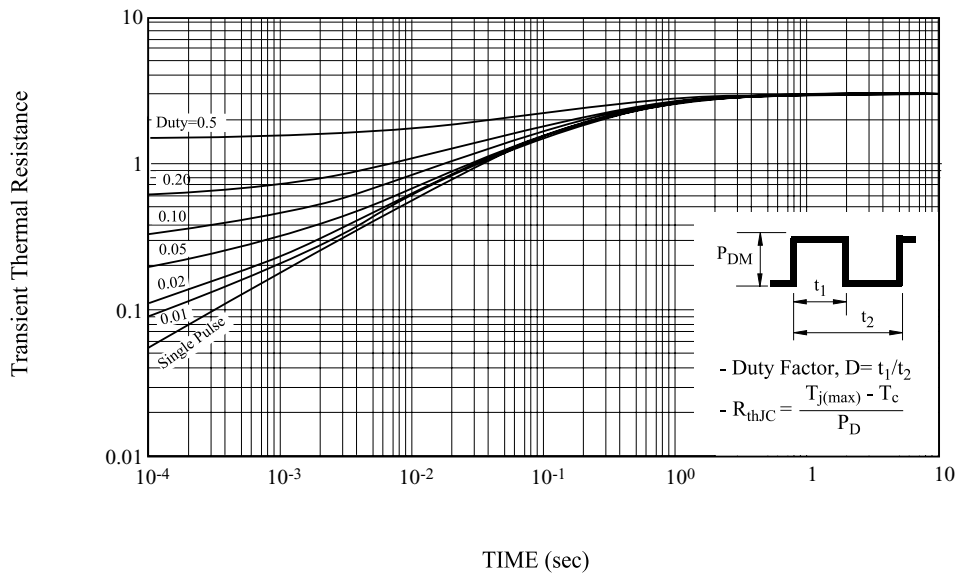

Fig12. Gate Charge

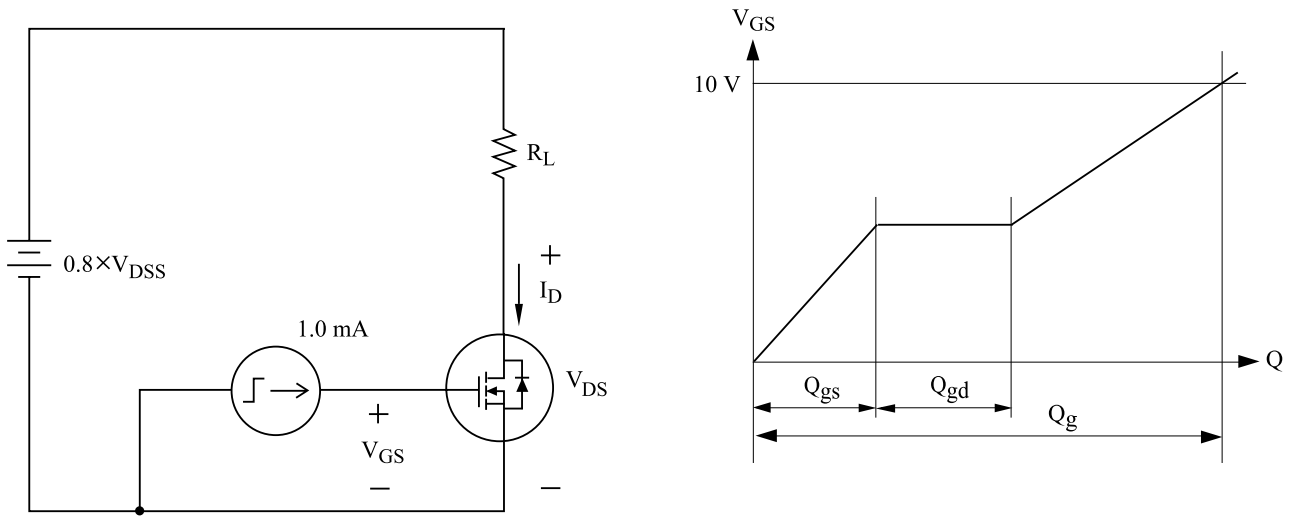

Fig13. Single Pulsed Avalanche Energy

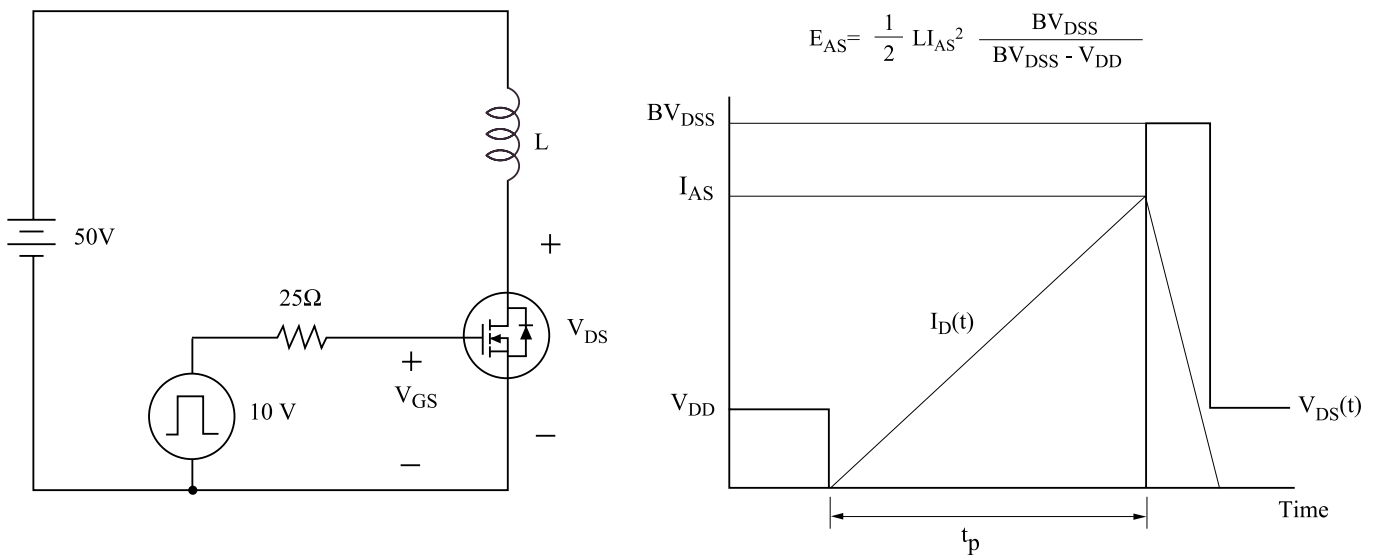
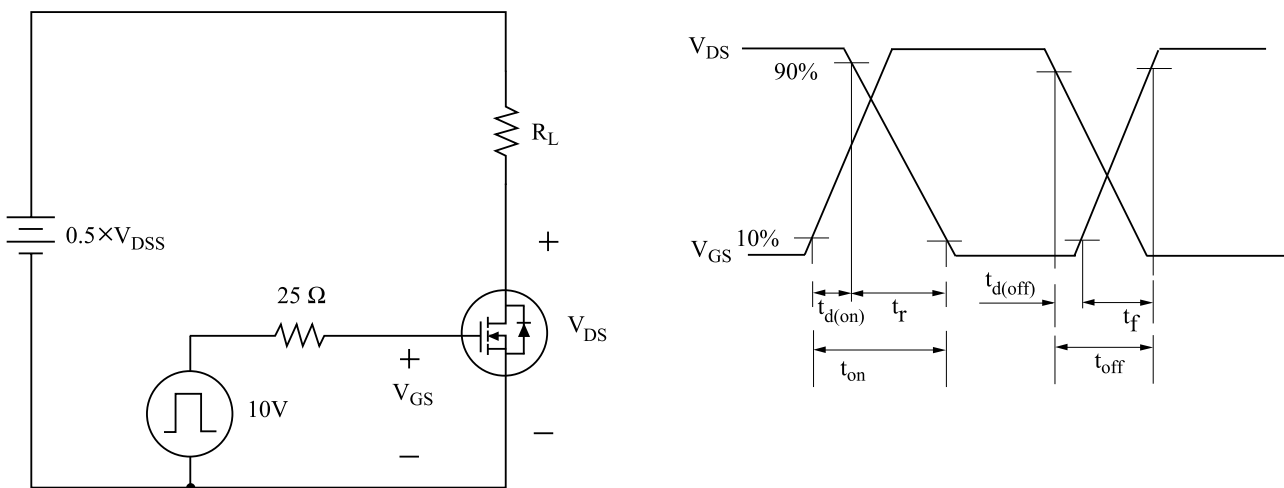

Fig14. Resistive Load Switching



KF3N40D/I

Fig15. Source - Drain Diode Reverse Recovery and dv/dt

