

GENERAL PURPOSE APPLICATION.

FEATURES

- Including two devices in TESV.
- (Thin Extreme Super mini type with 5 pin)
- Simplify circuit design.
- Reduce a quantity of parts and manufacturing process.

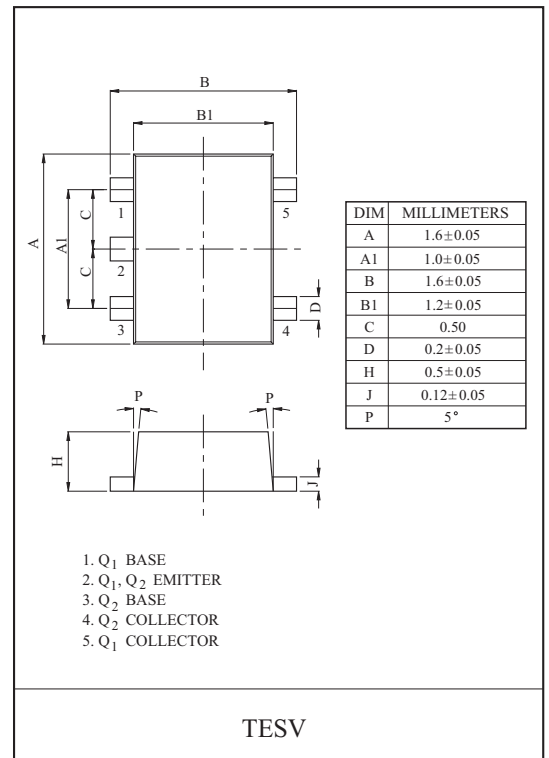

EQUIVALENT CIRCUIT(TOP VIEW)

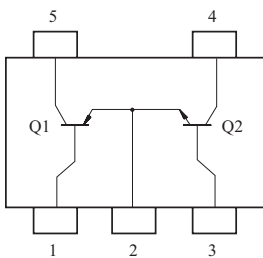

Marking

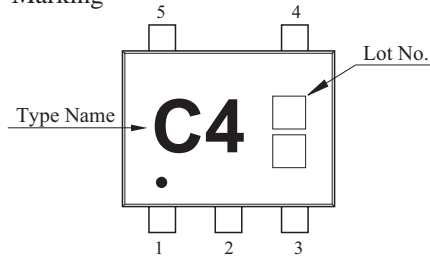

Q1 MAXIMUM RATING (Ta=25 °C)

CHARACTERISTIC	SYMBOL	RATING	UNIT
Collector-Base Voltage	V_{CBO}	-50	V
Collector-Emitter Voltage	V_{CEO}	-50	V
Emitter-Base Voltage	V_{EBO}	-5	V
Collector Current	I_C	-150	mA
Base Current	I_B	-30	mA

Q2 MAXIMUM RATING (Ta=25 °C)

CHARACTERISTIC	SYMBOL	RATING	UNIT
Collector-Base Voltage	V_{CBO}	60	V
Collector-Emitter Voltage	V_{CEO}	50	V
Emitter-Base Voltage	V_{EBO}	5	V
Collector Current	I_C	150	mA
Base Current	I_B	30	mA

Q1 Q2 MAXIMUM RATING (Ta=25 °C)

CHARACTERISTIC	SYMBOL	RATING	UNIT
Collector Power Dissipation	P_C^*	200	mW
Junction Temperature	T_j	150	°C
Storage Temperature Range	T_{stg}	-55 ~ 150	°C

* Total Rating.

KTX201E

Q₁ ELECTRICAL CHARACTERISTICS (Ta=25 °C)

CHARACTERISTIC	SYMBOL	TEST CONDITION	MIN.	TYP.	MAX.	UNIT.
Collector Cut-off Current	I _{CBO}	V _{CB} =-50V, I _E =0	-	-	-0.1	μA
Emitter Cut-off Current	I _{EBO}	V _{EB} =-5V, I _C =0	-	-	-0.1	μA
DC Current Gain	h _{FE} (Note)	V _{CE} =-6V, I _C =-2mA	120	-	400	
Collector-Emitter Saturation Voltage	V _{CE(SAT)}	I _C =-100mA, I _B =-10mA	-	-0.1	-0.3	V
Transition Frequency	f _T	V _{CE} =-10V, I _C =-1mA	80	-	-	MHz
Collector Output Capacitance	C _{ob}	V _{CB} =-10V, I _E =0, f=1MHz	-	4.0	7.0	pF
Noise Figure	NF	V _{CE} =-6V, I _C =-0.1mA, f=1kHz, R _g =10kΩ	-	1.0	10	dB

Note)h_{FE} Classification : Y(4)120~240, GR(6)200~400

Q₂ ELECTRICAL CHARACTERISTICS (Ta=25 °C)

CHARACTERISTIC	SYMBOL	TEST CONDITION	MIN.	TYP.	MAX.	UNIT.
Collector Cut-off Current	I _{CBO}	V _{CB} =60V, I _E =0	-	-	0.1	μA
Emitter Cut-off Current	I _{EBO}	V _{EB} =5V, I _C =0	-	-	0.1	μA
DC Current Gain	h _{FE} (Note)	V _{CE} =6V, I _C =2mA	120	-	400	
Collector-Emitter Saturation Voltage	V _{CE(SAT)}	I _C =100mA, I _B =10mA	-	0.1	0.25	V
Transition Frequency	f _T	V _{CE} =10V, I _C =1mA	80	-	-	MHz
Collector Output Capacitance	C _{ob}	V _{CB} =10V, I _E =0, f=1MHz	-	2.0	3.5	pF
Noise Figure	NF	V _{CE} =6V, I _C =0.1mA, f=1kHz, R _g =10kΩ	-	1.0	10	dB

Note)h_{FE} Classification : Y(4)120~240, GR(6)200~400

Q₁ (PNP TRANSISTOR)

$I_C - V_{CE}$

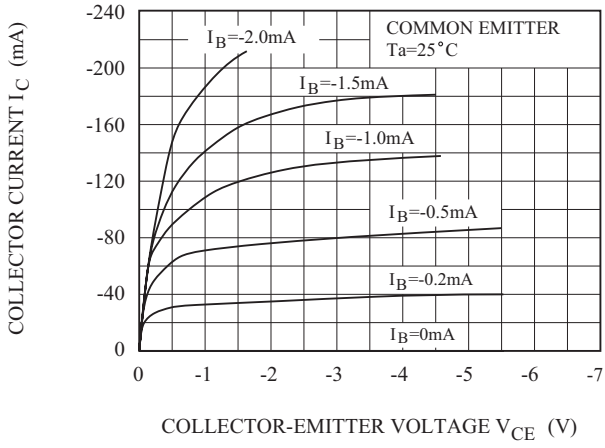

$h_{FE} - I_C$

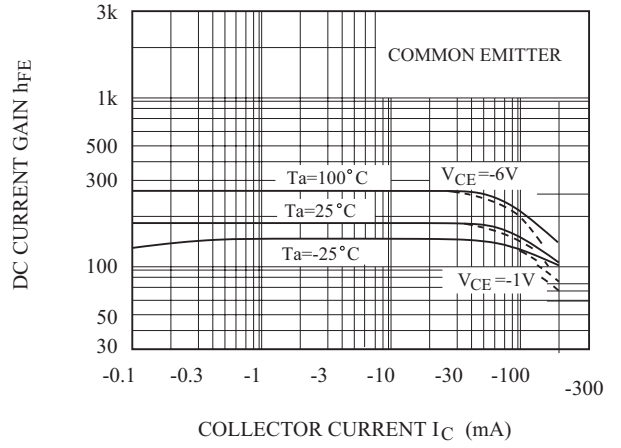

$V_{CE(sat)} - I_C$

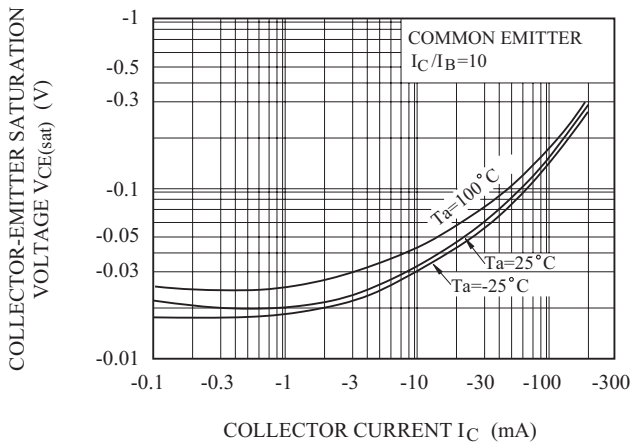

$V_{BE(sat)} - I_C$

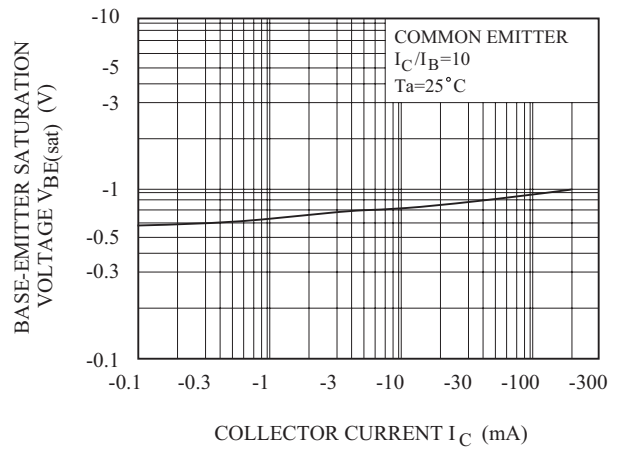

$f_T - I_C$

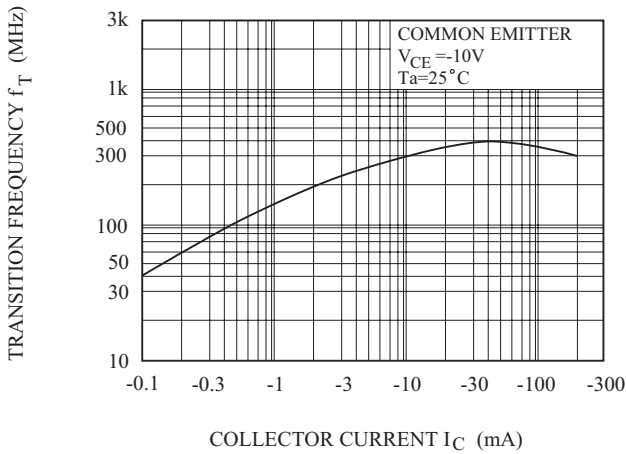

$I_B - V_{BE}$

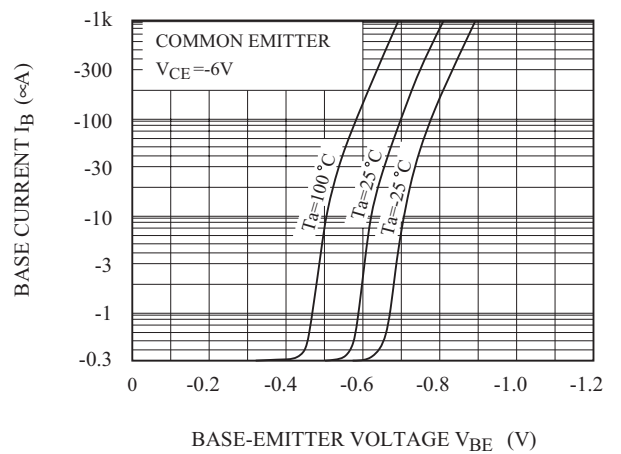

Q₂ (NPN TRANSISTOR)

$I_C - V_{CE}$

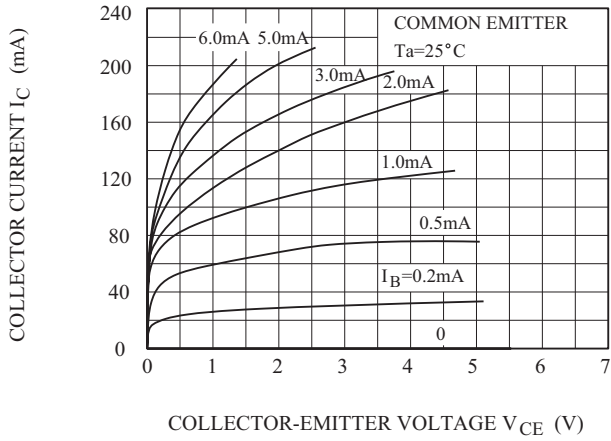

$h_{FE} - I_C$

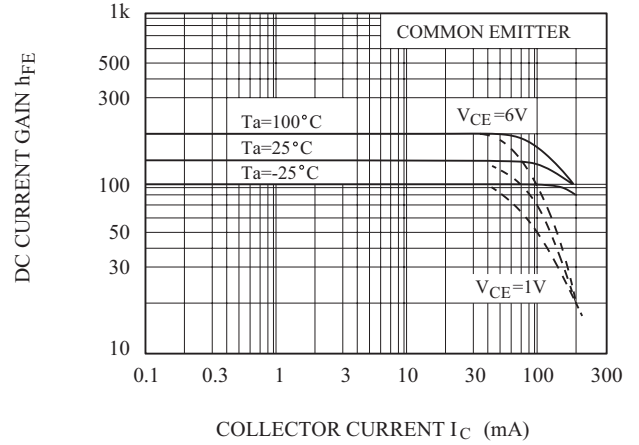

$V_{CE(sat)} - I_C$

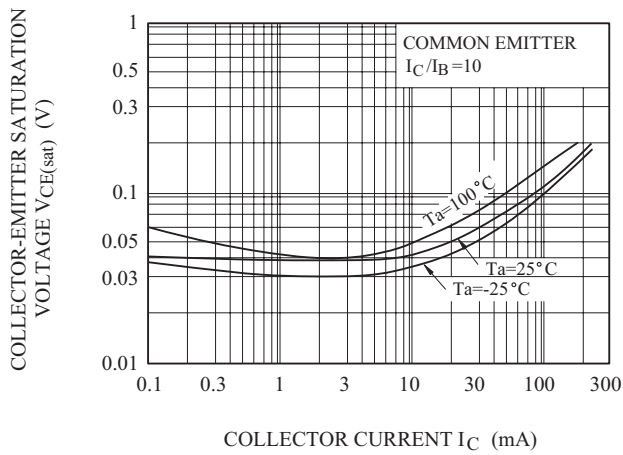

$V_{BE(sat)} - I_C$

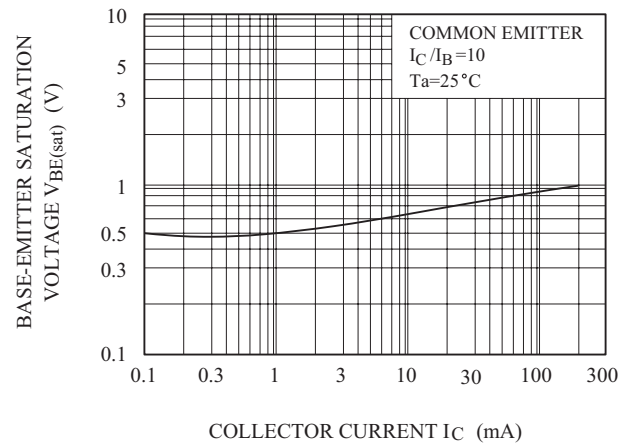

$f_T - I_C$

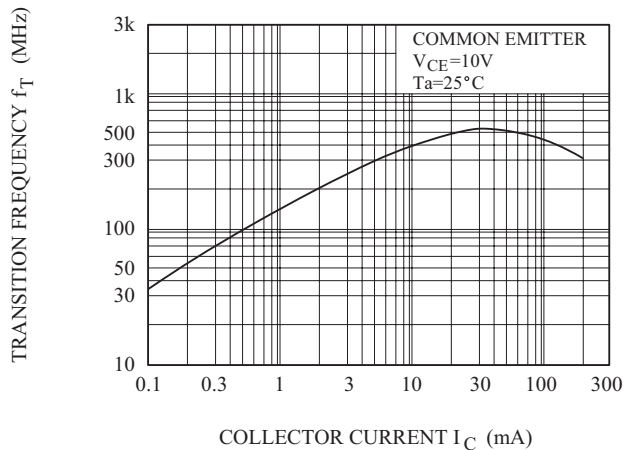

$I_B - V_{BE}$

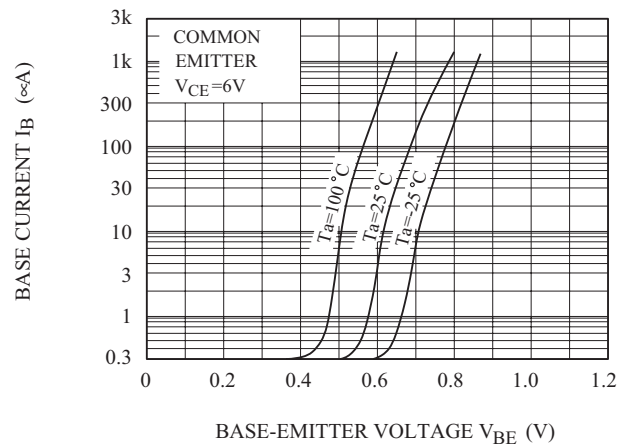

KTX201E

