

SILICON PLANAR EPITAXIAL PNP TRANSISTOR

BUX78

- High Power
- Hermetic TO-66 Metal Package
- Ideally suited for Driver Circuits, Switching and Amplifier Applications
- Screening Options Available

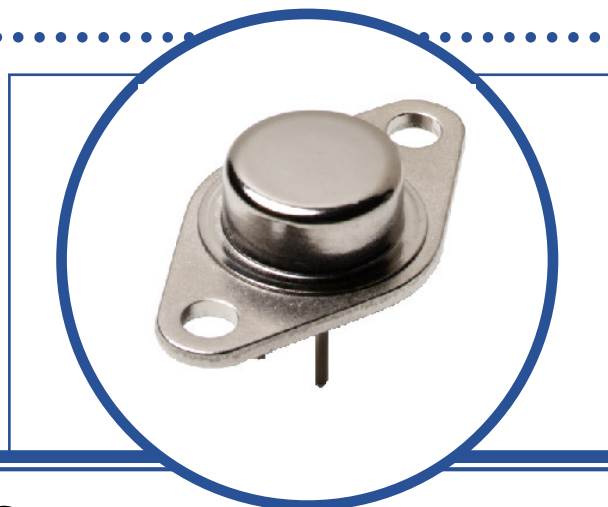

ABSOLUTE MAXIMUM RATINGS ($T_C = 25^\circ\text{C}$ unless otherwise stated)

V_{CBO}	Collector – Base Voltage	-100V
V_{CEO}	Collector – Emitter Voltage	-80V
V_{EBO}	Emitter – Base Voltage	-6V
I_C	Continuous Collector Current	5A
I_B	Base Current	0.8A
P_D	Total Power Dissipation at $T_C = 25^\circ\text{C}$	40W
	Derate Above 25°C	0.23W/ $^\circ\text{C}$
T_J	Junction Temperature Range	-65 to $+200^\circ\text{C}$
T_{stg}	Storage Temperature Range	-65 to $+200^\circ\text{C}$

THERMAL PROPERTIES

Symbols	Parameters	Min.	Typ.	Max.	Units
$R_{\theta JC}$	Thermal Resistance, Junction To Case			4.4	$^\circ\text{C/W}$

Semelab Limited reserves the right to change test conditions, parameter limits and package dimensions without notice. Information furnished by Semelab is believed to be both accurate and reliable at the time of going to press. However Semelab assumes no responsibility for any errors or omissions discovered in its use. Semelab encourages customers to verify that datasheets are current before placing orders.



SILICON PLANAR EPITAXIAL PNP TRANSISTOR BUX78

ELECTRICAL CHARACTERISTICS ($T_C = 25^\circ\text{C}$ unless otherwise stated)

Symbols	Parameters	Test Conditions	Min.	Typ	Max.	Units
$V_{(BR)CEO}^{(1)}$	Collector-Emitter Breakdown Voltage	$I_C = -50\text{mA}$ $I_B = 0$	-80			V
$V_{(BR)CES}$	Collector-Emitter Breakdown Voltage	$I_C = -2\text{mA}$ $V_{BE} = 0$	-100			
$V_{(BR)EBO}$	Emitter-Base Breakdown Voltage	$I_E = -1.0\text{mA}$ $I_C = 0$	-6			
I_{CEO}	Collector Cut-Off Current	$V_{CE} = -60\text{V}$ $I_B = 0$			-10	μA
I_{CBO}	Collector Cut-Off Current	$V_{CB} = -80\text{V}$ $I_E = 0$			-0.5	
		$T_C = 150^\circ\text{C}$			-150	
I_{EBO}	Emitter Cut-Off Current	$V_{EB} = -4\text{V}$ $I_C = 0$			-0.5	
$h_{FE}^{(1)}$	Forward-current transfer ratio	$I_C = -0.5\text{A}$ $V_{CE} = -5\text{V}$	50			
		$I_C = -2\text{A}$ $V_{CE} = -5\text{V}$	50		120	
		$I_C = -5\text{A}$ $V_{CE} = -5\text{V}$	30			
		$I_C = -1.0\text{A}$ $V_{CE} = -5\text{V}$ $T_C = -40^\circ\text{C}$	25			
$V_{CE(sat)}^{(1)}$	Collector-Emitter Saturation Voltage	$I_C = -5\text{A}$ $I_B = -0.5\text{A}$			-1.0	V
$V_{BE(sat)}^{(1)}$	Base-Emitter Saturation Voltage	$I_C = -5\text{A}$ $I_B = -0.5\text{A}$			-1.3	

DYNAMIC CHARACTERISTICS

$ h_{fel} $	Small signal forward-current transfer ratio	$I_C = -0.5\text{A}$ $V_{CE} = -5\text{V}$ $f = 20\text{MHz}$	1.5			
t_{on}	Turn-On Time	$I_C = -5\text{A}$ $V_{CC} = -40\text{V}$ $I_{B1} = -0.5\text{A}$		0.3	0.4	μs
t_{off}	Turn-Off Time	$I_C = -5\text{A}$ $V_{CC} = -40\text{V}$ $I_{B1} = -I_{B2} = -0.5\text{A}$		1.1	2.5	

Notes

(1) Pulse Width $\leq 300\mu\text{s}$, $\delta \leq 2\%$

SILICON PLANAR EPITAXIAL PNP TRANSISTOR BUX78

MECHANICAL DATA

Dimensions in mm (inches)

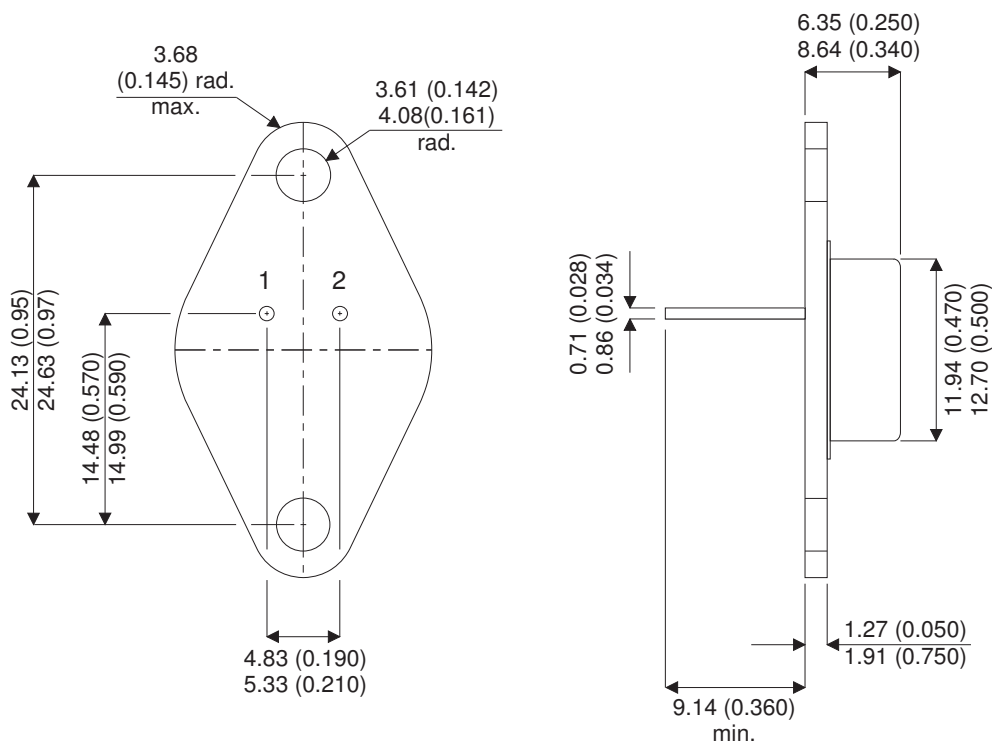

TO66 (TO-213AA)

Pin 1 - Base

Pin 2 - Emitter

Case - Collector