



**MMDT2227**

Preliminary

**DUAL TRANSISTOR**

**NPN & PNP GENERAL PURPOSE AMPLIFIER**

■ DESCRIPTION

The UTC **MMDT2227** is an NPN & PNP general purpose amplifier. it's suitable for a medium power amplifier and switch requiring collector currents up to 500mA.

■ FEATURES

- \* Low  $V_{CE(SAT)}$ ,  $V_{CE(SAT)}=0.4V$  (typ.)@ $I_C / I_B=150mA/15mA$ ,  
 $V_{CE(SAT)}=1.4V$  (typ.) @ $I_C / I_B = 300mA/30mA$
- \* High collector current gain under high collector current condition

■ EQUIVALENT CIRCUIT

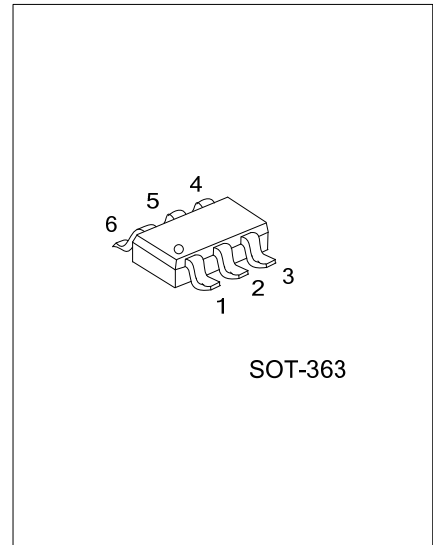
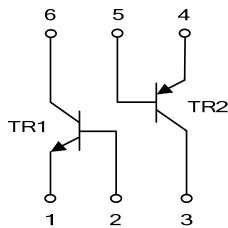

■ ORDERING INFORMATION

Ordering Number		Package	Pin Assignment						Packing
Lead Free	Halogen Free		1	2	3	4	5	6	
MMDT2227L-AL6-R	MMDT2227G-AL6-R	SOT-363	E1	B1	C2	E2	B2	C1	Tape Reel

<p>MMDT2227L-AL6-R</p> <p>(1) Packing Type          (2) Package Type          (3) Halogen Free</p>	<p>(1) R: Tape Reel          (2) AL6: SOT-363          (3) Halogen Free, L: Lead Free</p>
--	---

■ MARKING

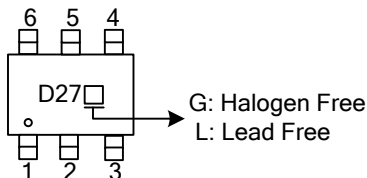

■ ABSOLUTE MAXIMUM RATINGS\* (T<sub>A</sub>=25°C , unless otherwise specified)(Note 2)

PARAMETER	SYMBOL	RATINGS	UNIT
Collector-Emitter Voltage	TR1	40	V
	TR2	-60	
Collector-Base Voltage	TR1	75	V
	TR2	-60	
Emitter-Base Voltage	TR1	6	V
	TR2	-5.0	
Collector Current - Continuous	TR1	0.6	mA
	TR2	-0.6	
Derate above 25°C	P <sub>D</sub>	200	mW
Junction Temperature	T <sub>J</sub>	+150	°C
Storage Temperature	T <sub>STG</sub>	-55 ~ +150	°C

Notes: 1. Absolute maximum ratings are those values beyond which the device could be permanently damaged.

Absolute maximum ratings are stress ratings only and functional device operation is not implied.

2. These ratings are limiting values above which the serviceability of any semiconductor device may be impaired.

■ THERMAL DATA

PARAMETER	SYMBOL	RATINGS	UNIT
Junction to Case	θ <sub>JC</sub>	415	°C/W

■ ELECTRICAL CHARACTERISTICS (T<sub>A</sub>=25°C unless otherwise specified)

TR1

PARAMETER	SYMBOL	TEST CONDITIONS	MIN	TYP	MAX	UNIT
<b>OFF CHARACTERISTICS</b>						
Collector-Emitter Breakdown Voltage	V <sub>(BR)CEO</sub>	I <sub>C</sub> =10mA, I <sub>B</sub> =0 (Note)	40			V
Collector-Base Breakdown Voltage	V <sub>(BR)CBO</sub>	I <sub>C</sub> =10 μA, I <sub>E</sub> =0	75			V
Emitter-Base Breakdown Voltage	V <sub>(BR)EBO</sub>	I <sub>E</sub> =10μA, I <sub>C</sub> =0	6			V
Collector Cutoff Current	I <sub>CB0</sub>	V <sub>CB</sub> = 60V, I <sub>E</sub> =0			10	nA
Emitter Cutoff Current	I <sub>EBO</sub>	V <sub>EB</sub> =3.0V, I <sub>C</sub> =0			10	nA
<b>ON CHARACTERISTICS</b>						
DC Current Gain	h <sub>FE</sub>	I <sub>C</sub> =0.1mA, V <sub>CE</sub> =10V	35			
		I <sub>C</sub> =1mA, V <sub>CE</sub> =10V	50			
		I <sub>C</sub> =10mA, V <sub>CE</sub> =10V	75			
		I <sub>C</sub> =150mA, V <sub>CE</sub> =10V	100		300	
		I <sub>C</sub> =150mA, V <sub>CE</sub> = 1V (Note)	50			
		I <sub>C</sub> =500mA, V <sub>CE</sub> =10V	40			
Collector-Emitter Saturation Voltage (Note)	V <sub>CE(SAT)</sub>	I <sub>C</sub> =150mA, I <sub>B</sub> =15mA			0.3	V
		I <sub>C</sub> =500mA, I <sub>B</sub> =50mA			1.0	V
Base-Emitter Saturation Voltage (Note)	V <sub>BE(SAT)</sub>	I <sub>C</sub> =150mA, I <sub>B</sub> =15mA	0.6		1.2	V
		I <sub>C</sub> =500mA, I <sub>B</sub> =50mA			2.0	V
<b>SMALL SIGNAL CHARACTERISTICS</b>						
Current Gain - Bandwidth Product	f <sub>T</sub>	I <sub>C</sub> = 20mA, V <sub>CE</sub> =20V, f =100MHz	300			MHz
Output Capacitance	C <sub>OB</sub>	V <sub>CB</sub> =10 V, I <sub>E</sub> =0, f=100 kHz			8	pF
Input Capacitance	C <sub>IB</sub>	V <sub>EB</sub> =0.5V, I <sub>C</sub> =0, f=100 kHz			25	pF
Noise Figure	NF	I <sub>C</sub> =100μA, V <sub>CE</sub> =10V, R <sub>S</sub> =1.0kΩ, f =1.0kHz			4	dB

Note: Pulse Test: Pulse Width ≤ 300μs, Duty Cycle ≤ 2.0%

■ ELECTRICAL CHARACTERISTICS ( $T_A=25^\circ\text{C}$  unless otherwise specified)

## TR2

PARAMETER	SYMBOL	TEST CONDITIONS	MIN	TYP	MAX	UNIT
<b>OFF CHARACTERISTICS</b>						
Collector-Emitter Breakdown Voltage	$V_{(BR)CEO}$	$I_C=-10\text{mA}, I_B=0$ (Note)	-60			V
Collector-Base Breakdown Voltage	$V_{(BR)CBO}$	$I_C=-10\ \mu\text{A}, I_E=0$	-60			V
Emitter-Base Breakdown Voltage	$V_{(BR)EBO}$	$I_E=-10\ \mu\text{A}, I_C=0$	-5.0			V
Collector Cutoff Current	$I_{CBO}$	$V_{CB}=-50\text{V}, I_E=0$			-20	nA
Emitter Cutoff Current	$I_{EBO}$	$V_{EB}=-3.0\text{V}, I_C=0$			-30	nA
<b>ON CHARACTERISTICS</b>						
DC Current Gain	$h_{FE}$	$I_C=-0.1\text{mA}, I_B=-10\text{mA}$	75			
		$I_C=-1.0\text{mA}, V_{CE}=-10\text{V}$	100			
		$I_C=-10\text{mA}, V_{CE}=-10\text{V}$	100			
		$I_C=-150\text{mA}, V_{CE}=-10\text{V}$ (Note)	100		300	
		$I_C=-500\text{mA}, V_{CE}=-10\text{V}$ (Note)	50			
Collector-Emitter Saturation Voltage (Note)	$V_{CE(SAT)}$	$I_C=-150\text{mA}, I_B=-15\text{mA}$			-0.4	V
		$I_C=-300\text{mA}, I_B=-30\text{mA}$			-1.6	V
Base-Emitter Saturation Voltage (Note)	$V_{BE(SAT)}$	$I_C=-150\text{mA}, I_B=-15\text{mA}$			-1.3	V
		$I_C=-500\text{mA}, I_B=-50\text{mA}$			-2.6	V
<b>SMALL SIGNAL CHARACTERISTICS</b>						
Current Gain - Bandwidth Product	$f_T$	$I_C=-50\text{mA}, V_{CE}=-20\text{V}, f=100\text{MHz}$	200			MHz
Output Capacitance	$C_{OB}$	$V_{CB}=-10\text{V}, I_E=0, f=100\ \text{kHz}$			8	pF
Input Capacitance	$C_{IB}$	$V_{EB}=-2.0\text{V}, I_C=0, f=100\ \text{kHz}$			30	pF
Noise Figure	NF	$I_C=-100\ \mu\text{A}, V_{CE}=-10\text{V}, R_S=1.0\text{k}\Omega, f=1.0\text{kHz}$		2.0		dB

Note: Pulse Test: Pulse Width  $\leq 300\ \mu\text{s}$ , Duty Cycle  $\leq 2.0\%$

UTC assumes no responsibility for equipment failures that result from using products at values that exceed, even momentarily, rated values (such as maximum ratings, operating condition ranges, or other parameters) listed in products specifications of any and all UTC products described or contained herein. UTC products are not designed for use in life support appliances, devices or systems where malfunction of these products can be reasonably expected to result in personal injury. Reproduction in whole or in part is prohibited without the prior written consent of the copyright owner. The information presented in this document does not form part of any quotation or contract, is believed to be accurate and reliable and may be changed without notice.