

MECHANICAL DATA

Dimensions in mm (inches)

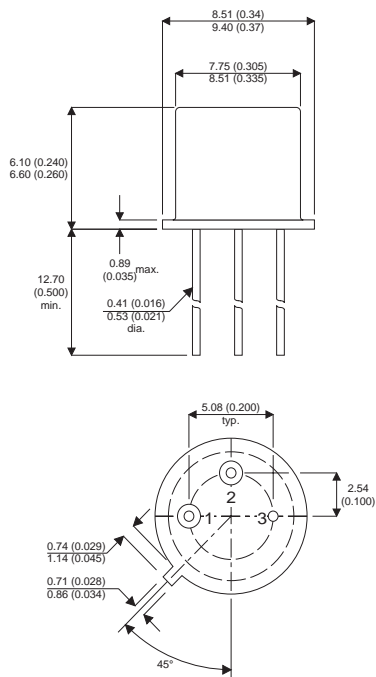

TO-39 (TO-205AD)

Pin 1 – Emitter Pin 2 – Base Pin 3 – Collector

ABSOLUTE MAXIMUM RATINGS

$T_{CASE} = 25^{\circ}C$ unless otherwise stated

		2N5322	2N5323
V_{CBO}	Collector – Base Voltage ($I_E = 0$)	-100V	-75V
V_{CEV}	Collector – Emitter Voltage ($V_{BE} = 1.5v$)	-100V	-75V
V_{CEO}	Emitter – Base Voltage ($I_B = 0$)	-75V	-50V
V_{EBO}	Emitter – Base Voltage ($I_C = 0$)	-6V	-5V
I_C	Continuous Collector Current	-1.2A	
I_B	Base Current	-1A	
P_{tot}	Total Dissipation at $T_{amb} = 25^{\circ}C$	1W	
	$T_{case} = 50^{\circ}C$	10W	
T_{stg}, T_j	Storage and Junction temperature	-65 to +200°C	

THERMAL DATA

Parameter	Description	Max	Value	Unit
$R_{thj-case}$	Thermal Resistance Junction-Case	Max	17.5	°C/W
$R_{thj-amb}$	Thermal Resistance Junction-Ambient	Max	175	°C/W

Semelab Plc reserves the right to change test conditions, parameter limits and package dimensions without notice. Information furnished by Semelab is believed to be both accurate and reliable at the time of going to press. However Semelab assumes no responsibility for any errors or omissions discovered in its use. Semelab encourages customers to verify that datasheets are current before placing orders.

Semelab plc. Telephone +44(0)1455) 556565. Fax +44(0)1455) 552612.

E-mail: sales@semelab.co.uk Website: <http://www.semelab.co.uk>

Document Number 3073
Issue 2

HIGH SPEED MEDIUM VOLTAGE SWITCHES

DESCRIPTION

The 2N5322 and 2N5323 are silicon planar epitaxial PNP transistors in jedec TO-39 metal case intended for high voltage medium power applications in industrial and commercial equipment.

The complementary NPN types are the 2N5320 and 2N5321 respectively

ELECTRICAL CHARACTERISTICS FOR ($T_{case} = 25^{\circ}C$ unless otherwise stated)

Parameter	Test Conditions	Min.	Typ.	Max.	Unit
I_{CBO} Collector Cut Off Current	$V_{CB} = -80V$ $I_E = 0$ 2N5322			-0.5	μA
	$V_{CB} = -60V$ $I_E = 0$ 2N5323			-5	
I_{EBO} Emitter Cut Off Current	$V_{EB} = -5V$ $I_C = 0$ 2N5322		-0.1		μA
	$V_{EB} = -4V$ $I_C = 0$ 2N5323		-0.5		
$V_{(BR)CEV}$ Collector Emitter Breakdown Voltage	$V_{BE} = 1.5V$ $I_C = -0.1mA$				V
	2N5322	-100			
	2N5323	-75			
$V_{(BR)CEO^*}$ Collector-Emitter Breakdown Voltage	$I_C = -10mA$ $I_B = 0$				V
	2N5322	-75			
	2N5323	-50			
$V_{(BR)EBO}$ Emitter Base Breakdown Voltage	$I_E = -0.1mA$ $I_C = 0$				V
	2N5322	-6			
	2N5323	-5			
$V_{CE(sat)^*}$ Collector Emitter Saturation Voltage	$I_C = -500mA$ $I_B = -50mA$				V
	2N5322			-0.7	
	2N5323			-1.2	
V_{BE^*} Base Emitter Voltage	$I_C = -500mA$ $V_{CE} = -4V$				V
	2N5322			-1.1	
	2N5323			-1.4	
h_{FE^*} DC Current Gain	$I_C = -500mA$ $V_{CE} = -4V$	30		130	—
	$I_C = -1A$ $V_{CE} = -2V$	10			
	2N5322				
	$I_C = -500mA$ $V_{CE} = -4V$	40		250	
	2N5323				
f_T Transistion Frequency	$I_C = -50mA$ $V_{CE} = -4V$	50			MHZ
t_{on} Turn-On Time	$I_C = -500mA$ $V_{CC} = -30V$ $I_{B1} = -50mA$			100	ns
t_{off} Turn Off Time	$I_C = -500mA$ $V_{CC} = -30V$ $I_{B1} = -I_{B2} = -50mA$			1000	

* Pulse test $t_p = 300\mu s$, $\delta = 1\%$