

NPN SILICON LOW POWER TRANSISTOR

Qualified per MIL-PRF-19500/376

DEVICES

2N2484 **2N2484UB**
2N2484UA **2N2484UBC ***

LEVELS

JAN
JANTX
JANTXV
JANS

* Available to JANS quality level only.

ABSOLUTE MAXIMUM RATINGS ($T_C = +25^\circ\text{C}$ unless otherwise noted)

Parameters / Test Conditions	Symbol	Value	Unit
Collector-Emitter Voltage	V_{CEO}	60	Vdc
Collector-Base Voltage	V_{CBO}	60	Vdc
Emitter-Base Voltage	V_{EBO}	6.0	Vdc
Collector Current	I_C	50	mAdc
Total Power Dissipation @ $T_A = +25^\circ\text{C}$ ⁽¹⁾	P_T	360	mW
Operating & Storage Junction Temperature Range	T_J, T_{stg}	-65 to +200	$^\circ\text{C}$

THERMAL CHARACTERISTICS

Parameters / Test Conditions	Symbol	Value	Unit
Thermal Resistance, Ambient-to-Case	$R_{\theta JA}$	325	$^\circ\text{C/W}$
2N2484			
2N2484UA			
2N2484UB, UBC			

1. See 19500/376 for Thermal Performance Curves.

ELECTRICAL CHARACTERISTICS ($T_A = +25^\circ\text{C}$, unless otherwise noted)

Parameters / Test Conditions	Symbol	Min.	Max.	Unit
OFF CHARACTERISTICS				
Collector-Emitter Breakdown Voltage $I_C = 10\text{mAdc}$	$V_{(BR)CEO}$	60		Vdc
Collector-Emitter Cutoff Current $V_{CE} = 45\text{Vdc}$	I_{CES}		5.0	ηAdc
Collector-Base Cutoff Current $V_{CB} = 45\text{Vdc}$ $V_{CB} = 60\text{Vdc}$	I_{CBO}		5.0 10	ηAdc μAdc
Collector-Emitter Cutoff Current $V_{CE} = 5.0\text{Vdc}$	I_{CEO}		2.0	ηAdc

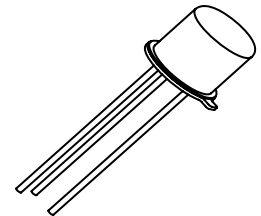

TO-18 (TO-206AA)
2N2484

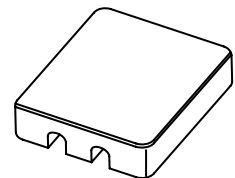

2N2484UA

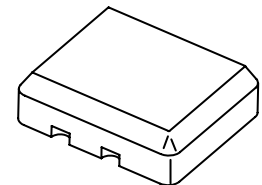

2N2484UB, UBC
 (UBC = Ceramic Lid Version)

ELECTRICAL CHARACTERISTICS ($T_A = +25^\circ\text{C}$, unless otherwise noted)

Parameters / Test Conditions	Symbol	Min.	Max.	Unit
OFF CHARACTERISTICS				
Emitter-Base Cutoff Current $V_{EB} = 5.0\text{Vdc}$ $V_{EB} = 6.0\text{Vdc}$	I_{EBO}		2.0 10	ηAdc μAdc
ON CHARACTERISTICS ⁽²⁾				
Forward-Current Transfer Ratio $I_C = 1.0\mu\text{A}$, $V_{CE} = 5.0\text{Vdc}$ $I_C = 10\mu\text{A}$, $V_{CE} = 5.0\text{Vdc}$ $I_C = 100\mu\text{A}$, $V_{CE} = 5.0\text{Vdc}$ $I_C = 500\mu\text{A}$, $V_{CE} = 5.0\text{Vdc}$ $I_C = 1.0\text{mA}$, $V_{CE} = 5.0\text{Vdc}$ $I_C = 10\text{mA}$, $V_{CE} = 5.0\text{Vdc}$	h_{FE}	45 200 225 250 250 225	500 675 800 800	
Collector-Emitter Saturation Voltage $I_C = 1.0\text{mA}$, $I_B = 100\mu\text{A}$	$V_{CE(sat)}$		0.3	Vdc
Base-Emitter Voltage $V_{CE} = 5.0\text{Vdc}$, $I_C = 100\mu\text{A}$	$V_{BE(ON)}$	0.5	0.7	Vdc

DYNAMIC CHARACTERISTICS

Parameters / Test Conditions	Symbol	Min.	Max.	Unit
Forward Current Transfer Ratio $I_C = 50\mu\text{A}$, $V_{CE} = 5.0\text{Vdc}$, $f = 5.0\text{MHz}$ $I_C = 500\mu\text{A}$, $V_{CE} = 5.0\text{Vdc}$, $f = 30\text{MHz}$	$ h_{fe} $	3.0 2.0	0.7	
Open Circuit Output Admittance $I_C = 1.0\text{mA}$, $V_{CE} = 5.0\text{Vdc}$, $f = 1.0\text{kHz}$	h_{oe}		40	μmhos
Open Circuit Reverse-Voltage Transfer Ratio $I_C = 1.0\text{mA}$, $V_{CE} = 5.0\text{Vdc}$, $f = 1.0\text{kHz}$	h_{re}		8.0×10^{-4}	
Input Impedance $I_C = 1.0\text{mA}$, $V_{CE} = 5.0\text{Vdc}$, $f = 1.0\text{kHz}$	h_{je}	3.5	24	$\text{k}\Omega$
Small-Signal Short-Circuit Forward Current Transfer Ratio $I_C = 1.0\text{mA}$, $V_{CE} = 5.0\text{Vdc}$, $f = 1.0\text{kHz}$	h_{fe}	250	900	
Output Capacitance $V_{CB} = 5.0\text{Vdc}$, $I_E = 0$, $100\text{kHz} \leq f \leq 1.0\text{MHz}$	C_{obo}		5.0	pF
Input Capacitance $V_{EB} = 0.5\text{Vdc}$, $I_C = 0$, $100\text{kHz} \leq f \leq 1.0\text{MHz}$	C_{ibo}		6.0	pF

(2) Pulse Test: Pulse Width = 300 μs , Duty Cycle $\leq 2.0\%$.

PACKAGE DIMENSIONS

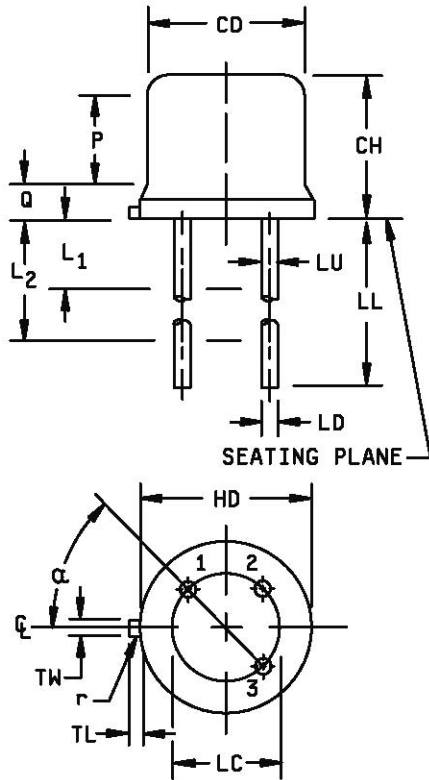

Symbol	Dimensions				Notes
	Inches		Millimeters		
	Min	Max	Min	Max	
CD	.178	.195	4.52	4.95	
CH	.170	.210	4.32	5.33	
HD	.209	.230	5.31	5.84	
LC	.100 TP		2.54 TP		6
LD	.016	.021	0.41	0.53	7,8
LL	.500	.750	12.70	19.05	7,8
LU	.016	.019	0.41	0.48	7,8
L1		.050		1.27	7,8
L2	.250		6.35		7,8
P	.100		2.54		
Q		.040		1.02	5
TL	.028	.048	0.71	1.22	3,4
TW	.036	.046	0.91	1.17	3
r		.010		0.25	10
α	45° TP		45° TP		6

NOTE:

1. Dimension are in inches.
2. Millimeters are given for general information only.
3. Beyond r (radius) maximum, TW shall be held for a minimum length of .011 inch (0.28 mm).
4. Dimension TL measured from maximum HD.
5. Body contour optional within zone defined by HD, CD, and Q.
6. Leads at gauge plane $.054 +.001 -.000$ inch ($1.37 +0.03 -.000$ mm) below seating plane shall be within .007 inch (0.18 mm) radius of true position (TP) at maximum material condition (MMC) relative to tab at MMC.
7. Dimension LU applies between L1 and L2. Dimension LD applies between L2 and LL minimum. Diameter is uncontrolled in L1 and beyond LL minimum.
8. All three leads.
9. The collector shall be internally connected to the case.
10. Dimension r (radius) applies to both inside corners of tab.
11. In accordance with ASME Y14.5M, diameters are equivalent to ϕx symbology.
12. Lead 1 = emitter, lead 2 = base, lead 3 = collector.

FIGURE 1. Physical dimensions (similar to TO-18).

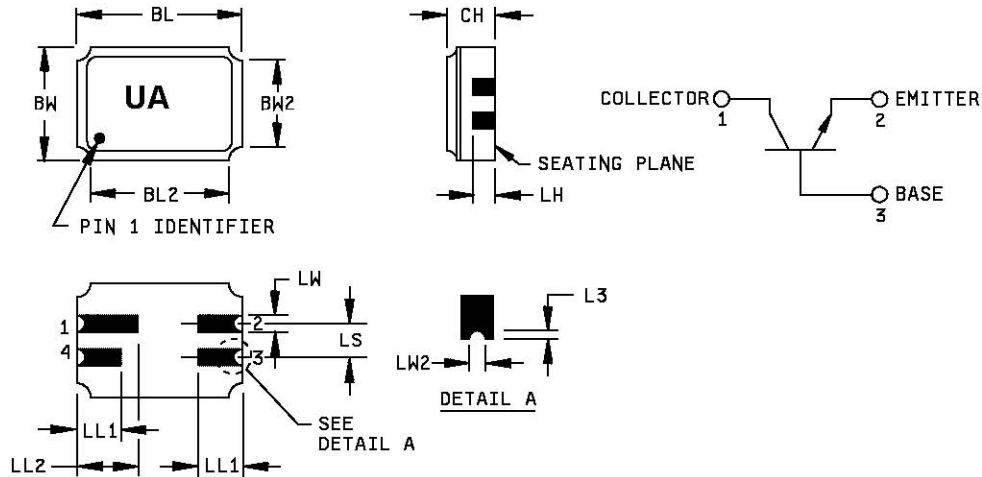

NOTE:

1. Dimensions are in inches.
2. Millimeters are given for general information only.
3. Dimension CH controls the overall package thickness. When a window lid is used, dimension CH must increase by a minimum of .010 inch (0.254 mm) and a maximum of .040 inch (1.020 mm).
4. The corner shape (square, notch, radius) may vary at the manufacturer's option, from that shown on the drawing.
5. Dimensions LW2 minimum and L3 minimum and the appropriate castellation length define an unobstructed three-dimensional space traversing all of the ceramic layers in which a castellation was designed. (Castellations are required on the bottom two layers, optional on the top ceramic layer.) Dimension LW2 maximum and L3 maximum define the maximum width and depth of the castellation at any point on its surface. Measurement of these dimensions may be made prior to solder dipping.
6. The co-planarity deviation of all terminal contact points, as defined by the device seating plane, shall not exceed .006 inch (0.15mm) for solder dipped leadless chip carriers.
7. In accordance with ASME Y14.5M, diameters are equivalent to ϕx symbology.

Symbol	Dimensions				Notes
	Inches		Millimeters		
	Min	Max	Min	Max	
BL	.215	.225	5.46	5.71	
BL2		.225		5.71	
BW	.145	.155	3.68	3.94	
BW2		.155		3.94	
CH	.061	.075	1.55	1.91	3
L3	.003	.007	0.08	0.18	5
LH	.029	.042	0.74	1.07	
LL1	.032	.048	0.81	1.22	
LL2	.072	.088	1.83	2.24	
LS	.045	.055	1.14	1.39	
LW	.022	.028	0.56	0.71	
LW2	.006	.022	0.15	0.56	5

Pin no.	1	2	3	4
Transistor	Collector	Emitter	Base	N/C

FIGURE 2. Physical dimensions, surface mount (2N2484UA).

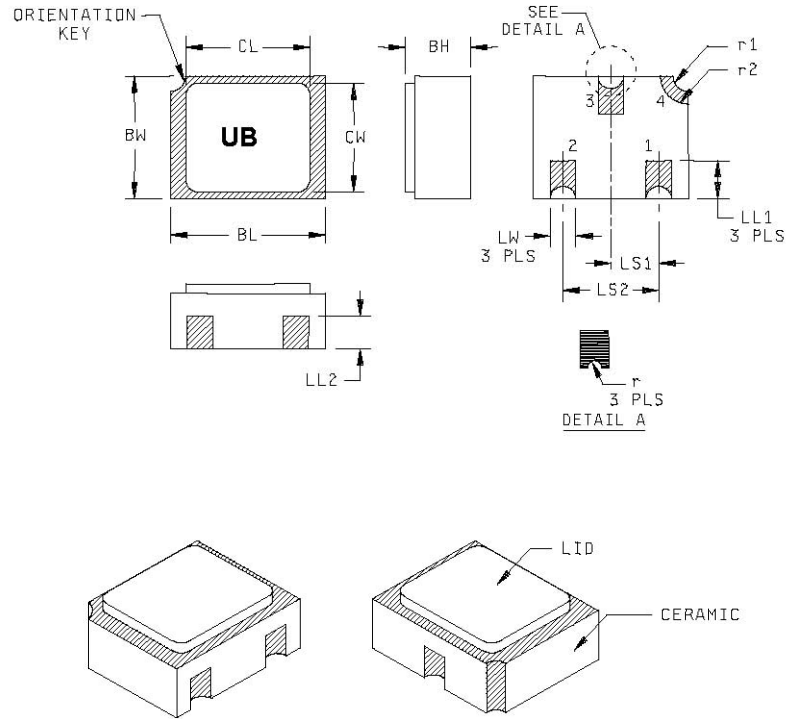

Symbol	Dimensions				Note
	Inches		Millimeters		
	Min	Max	Min	Max	
BH	.046	.056	1.17	1.42	
BL	.115	.128	2.92	3.25	
BW	.085	.108	2.16	2.74	
CL		.128		3.25	
CW		.108		2.74	
LL1	.022	.038	0.56	0.97	
LL2	.017	.035	0.43	0.89	

Symbol	Dimensions				Note
	Inches		Millimeters		
	Min	Max	Min	Max	
LS1	.036	.040	0.91	1.02	
LS2	.071	.079	1.80	2.01	
LW	.016	.024	0.41	0.61	
r		.008		.203	
r1		.012		.305	
r2		.022		.559	

NOTES:

1. Dimensions are in inches.
2. Millimeters are given for general information only.
3. Hatched areas on package denote metallized areas
4. Pad 1 = Base, Pad 2 = Emitter, Pad 3 = Collector, Pad 4 = Shielding connected to the lid.
5. In accordance with ASME Y14.5M, diameters are equivalent to ϕx symbology.

FIGURE 3. Physical dimensions, surface mount (2N2484UB).

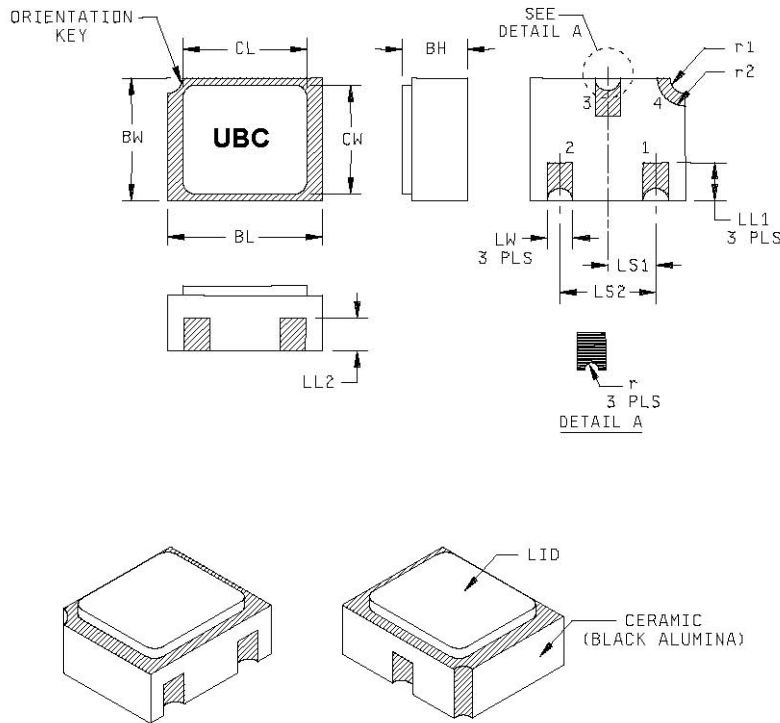

Symbol	Dimensions				Note
	Inches		Millimeters		
	Min	Max	Min	Max	
BH	.046	.071	1.17	1.80	
BL	.115	.128	2.92	3.25	
BW	.085	.108	2.16	2.74	
CL		.128		3.25	
CW		.108		2.74	
LL1	.022	.038	0.56	0.97	
LL2	.017	.035	0.43	0.89	

Symbol	Dimensions				Note
	Inches		Millimeters		
	Min	Max	Min	Max	
LS1	.036	.040	0.91	1.02	
LS2	.071	.079	1.80	2.01	
LW	.016	.024	0.41	0.61	
r		.008		.203	
r1		.012		.305	
r2		.022		.559	

NOTES:

1. Dimensions are in inches.
2. Millimeters are given for general information only.
3. Pad 1 = Base, Pad 2 = Emitter, Pad 3 = Collector, Pad 4 = connected to the lid braze ring.
4. In accordance with ASME Y14.5M, diameters are equivalent to ϕx symbology.

FIGURE 4. Physical dimensions, surface mount (2N2484UBC).