

1 Description

These N-Channel enhancement mode power field effect transistors are produced using planar stripe, DMOS technology.

This advanced technology has been especially tailored to minimize on-state resistance, provide superior switching performance, and withstand high energy pulse in the avalanche and commutation mode. These devices are well suited for high efficiency switched mode power supplies, active power factor correction based on half bridge topology.

2 Features

- 60V / 25A
- $R_{DS(on)} = 27m\Omega(\text{typ})$, $V_{GS} = 10V$, $I_D = 20A$
- Fast switching
- 100% avalanche tested
- Improved dv/dt capability..

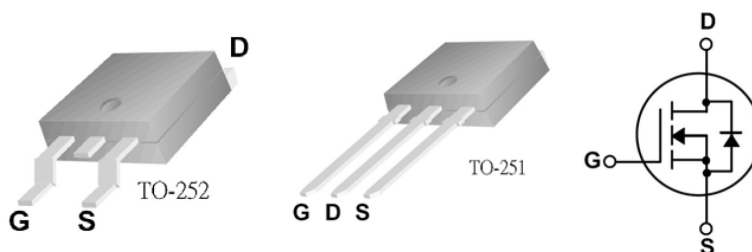

3 Absolute Maximum Ratings $T_C = 25^\circ\text{C}$ unless otherwise noted

Symbol	Parameter	APQ25SN06AA-XXM0	APQ25SN06AB-XXM0	Units
		APQ25SN06AA-XXJ0	APQ25SN06AB-XXJ1	
		APQ25SN06AA-XXF0	APQ25SN06AB-XXF0	
		TO-251	TO-252	
V_{DSS}	Drain-Source Voltage	60		V
I_D	Drain Current - Continuous ($T_C = 25^\circ\text{C}$) - Continuous ($T_C = 70^\circ\text{C}$)	25		A
		23.4		A
I_{DM}	Drain Current – Pulsed ①	100		A
V_{GS}	Gate-Source Voltage	± 20		V
P_D	Power Dissipation ($T_C = 25^\circ\text{C}$) - De-rate above 25°C	33		W
T_J, T_{STG}	Operating and Storage Temperature Range	-55 to +150		$^\circ\text{C}$

* note :

- ① Repetitive Rating: Pulse width limited by maximum junction temperature.

4 Thermal Characteristics

Symbol	Parameter	APQ25SN06AA-XXM0	APQ25SN06AB-XXM0	Units
		APQ25SN06AA-XXJ0	APQ25SN06AB-XXJ1	
		APQ25SN06AA-XXF0	APQ25SN06AB-XXF0	
		TO-251	TO-252	
$R_{\theta JC}$	Thermal Resistance, Junction-to-Case	3.8		$^{\circ}\text{C}/\text{W}$
$R_{\theta JA}$	Thermal Resistance, Junction-to-Ambient	62.5		$^{\circ}\text{C}/\text{W}$

 5 Electrical Characteristics $T_C = 25^{\circ}\text{C}$ unless otherwise noted

Symbol	Parameter	Test Conditions	Min	Typ	Max	Units
Off Characteristics						
BV_{DSS}	Drain-Source Breakdown Voltage	$V_{GS} = 0\text{ V}, I_D = 250\ \mu\text{A}$	60	--	--	V
I_{DSS}	Gate to Source leakage current	$V_{DS} = 48\text{ V}, V_{GS} = 0\text{ V}$	--	--	1	μA
I_{GSSF}	Gate-Body Leakage Current, Forward	$V_{GS} = 20\text{ V}, V_{DS} = 0\text{ V}$	--	--	100	nA
I_{GSSR}	Gate-Body Leakage Current, Reverse	$V_{GS} = -20\text{ V}, V_{DS} = 0\text{ V}$	--	--	-100	nA
On Characteristics						
$V_{GS(th)}$	Gate Threshold Voltage	$V_{DS} = V_{GS}, I_D = 250\ \mu\text{A}$	1.0	--	3.0	V
$R_{DS(on)}$	Static Drain-Source On-Resistance	$V_{GS} = 10\text{ V}, I_D = 20\text{ A}$ ①	--	27	32	m Ω
Dynamic Characteristics						
C_{iss}	Input Capacitance	$V_{DS} = 15\text{ V}, V_{GS} = 0\text{ V}, f = 1.0\text{ MHz}$	--	885	--	pF
C_{oss}	Output Capacitance		--	98	--	pF
C_{rss}	Reverse Transfer Capacitance		--	30	--	pF
Switching Characteristics						
$t_{d(on)}$	Turn-On Delay Time	$V_{DD} = 30\text{ V}, I_D = 20\text{ A}, R_G = 3\ \Omega$ ①	--	12	--	Ns
t_r	Turn-On Rise Time		--	8	--	Ns
$t_{d(off)}$	Turn-Off Delay Time		--	48	--	Ns
t_f	Turn-Off Fall Time		--	4	--	Ns
Q_g	Total Gate Charge	$V_{DS} = 30\text{ V}, I_D = 20\text{ A}, V_{GS} = 4.5\text{ V}$ ①	--	12	--	nC
Q_{gs}	Gate-Source Charge		--	4.8	--	nC
Q_{gd}	Gate-Drain Charge		--	6.2	--	nC
Drain-Source Diode Characteristics and Maximum Ratings						
V_{SD}	Drain-Source Diode Forward Voltage	$V_{GS} = 0\text{ V}, I_S = 1\text{ A}$	--	0.7	--	V

Notes:

 ① Pulse Test: Pulse width $\leq 300\ \mu\text{s}$, Duty cycle $\leq 2\%$. Depend on FT Test

6 Package Dimensions

APQ25SN06AA-XXM0
TO-251

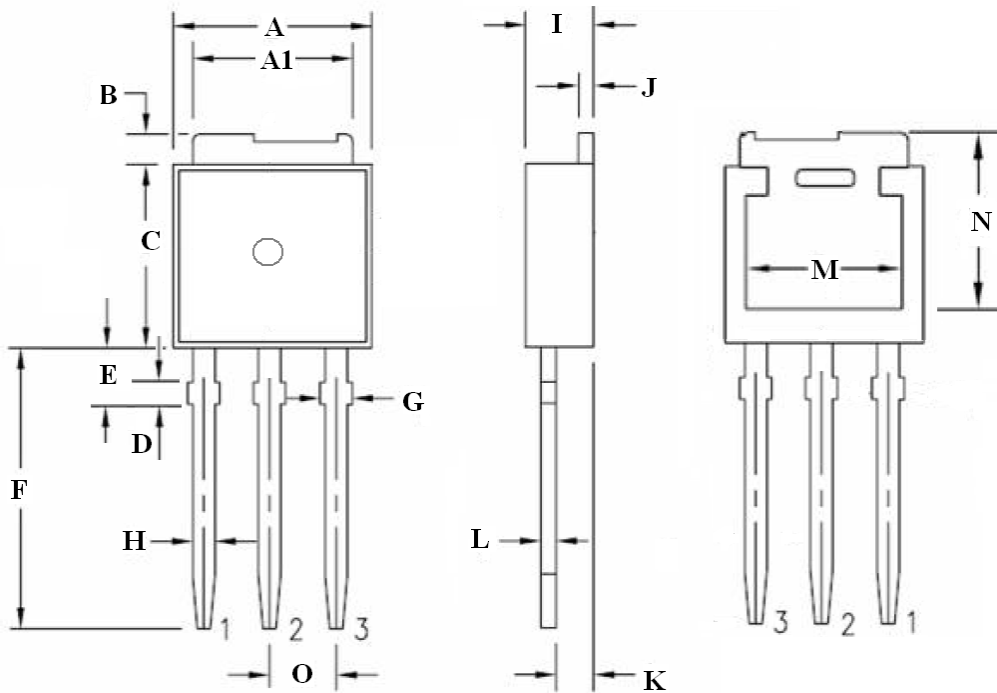

TO-251 DIMENSION							
DIM	MILLIMETERS						
	MIN	MAX	TYP.	DIM	MIN	MAX	TYP.
A	6.35	6.73	6.54	H	0.64	0.89	0.77
A1	4.95	5.46	5.21	I	2.18	2.39	2.29
B	0.89	1.27	1.08	J	0.46	0.89	0.66
C	5.97	6.22	6.10	K	0.89	1.14	1.02
D	1.14	1.52	1.33	L	0.46	0.61	0.54
E	1.91	2.29	2.10	M	4.32	--	--
F	8.89	9.65	9.27	N	5.21	-	-
G	0.84	1.14	0.99	O	2.29 BSC		

APQ25SN06AA-XXJ0
TO-251

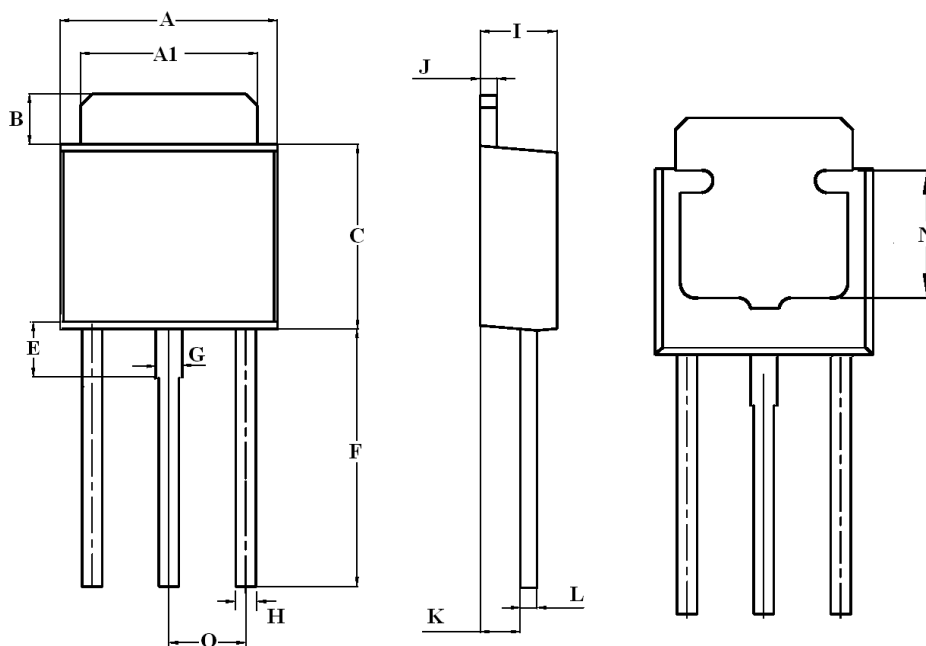

TO-251 DIMENSION							
DIM	MILLIMETERS						
	MIN	MAX	TYP.	DIM	MIN	MAX	TYP.
A	6.350	6.650	6.50	H	0.500	0.700	0.600
A1	5.200	5.400	5.300	I	2.200	2.400	2.300
B	1.350	1.650	1.500	J	0.430	0.580	0.505
C	5.400	5.700	5.550	K	1.050	1.350	1.2
E	1.91	2.29	2.100	L	0.430	0.580	0.505
F	7.500	7.900	7.700	N	3.800 REF.		
G	0.700	0.900	0.800	O	2.300 Typ.		

APQ25SN06AA-XXF0
TO-251

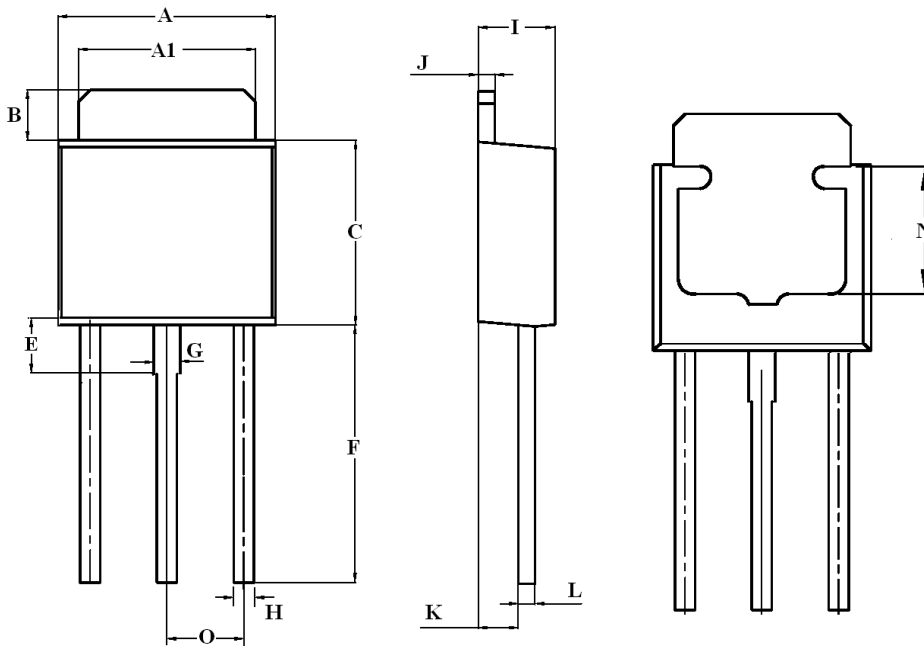

TO-251 DIMENSION							
DIM	MILLIMETERS						
	MIN	MAX	TYP.	DIM	MIN	MAX	TYP.
A	6.30	6.74	6.50	H	0.40	0.88	0.64
A1	4.80	5.46	5.13	I	2.10	2.50	2.30
B	1.30	1.70	1.50	J	0.40	0.60	0.50
C	5.30	6.23	5.76	K	1.10	1.30	1.20
E	0.91	1.80	1.35	L	0.43	0.58	0.50
F	6.98	8.00	7.50	N	3.800 REF.		
G	0.60	1.14	0.87	O	2.300 Typ.		

APQ25SN06AB-XXM0 TO-252

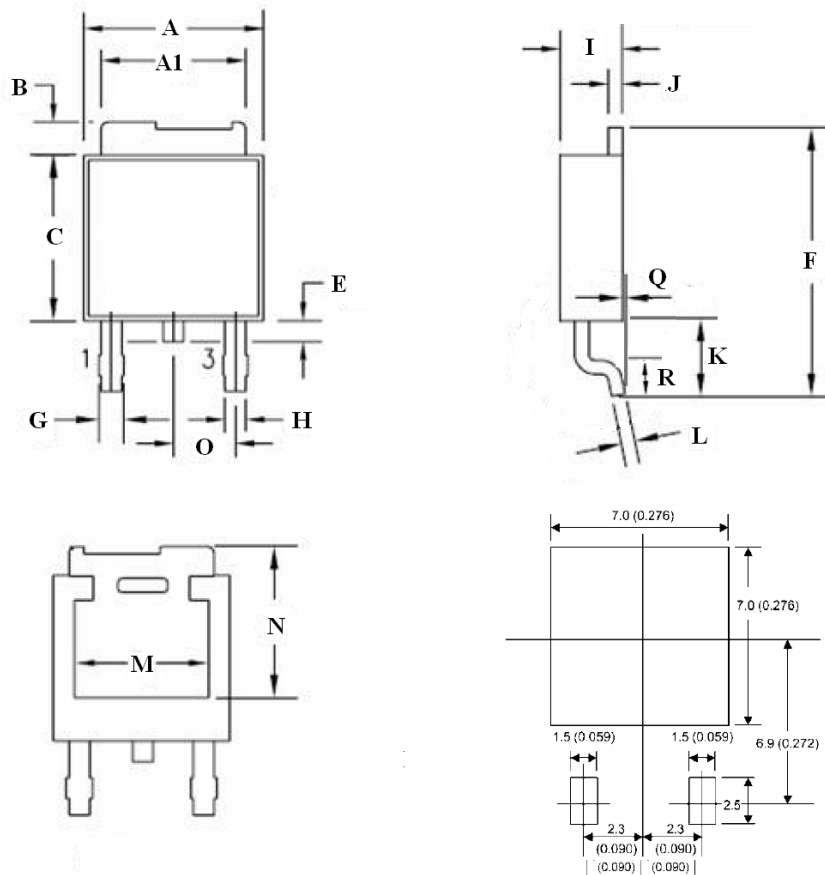

TO-252 DIMENSION							
DIM	MILLIMETERS						
	MIN	MAX	TYP.	DIM	MIN	MAX	TYP.
A	6.35	6.73	6.54	J	0.46	0.61	0.535
A1	5.21	5.46	5.335	K	2.550	2.900	2.725
B	0.89	1.27	1.08	L	0.46	0.61	0.535
C	5.97	6.22	6.095	M	4.83	--	
E	0.64	1.01	0.825	N	5.21	--	
F	9.65	10.14	9.895	O	2.29 BSC		
G	0.84	1.14	0.99	P	0.51 BSC		
H	0.64	0.89	0.765	Q	0	0.130	0.065
I	2.19	2.38	2.285	R	1.40	1.780	1.590

APQ25SN06AB-XXJ1
TO-252

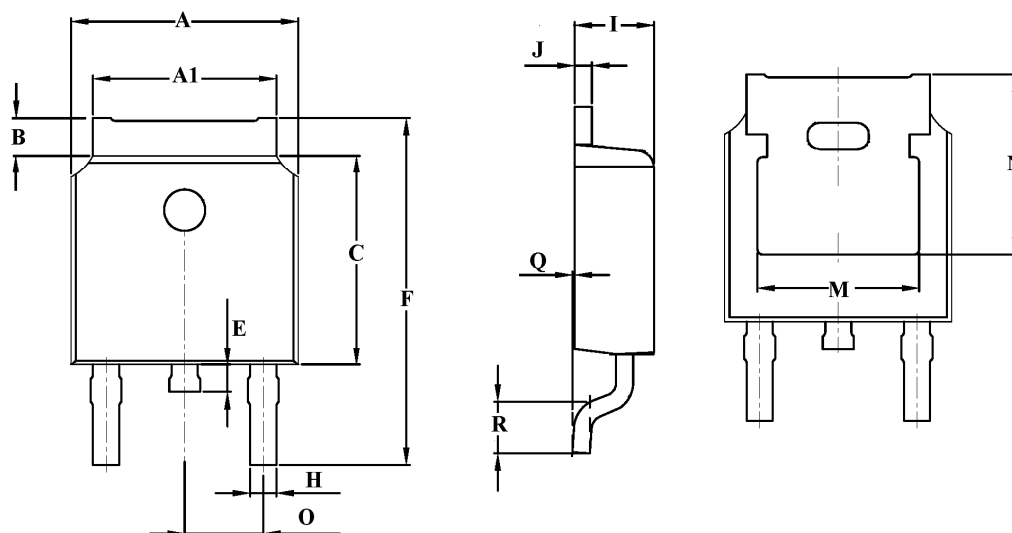

TO-252 DIMENSION							
DIM	MILLIMETERS						
	MIN	MAX	TYP.	DIM	MIN	MAX	TYP
A	6.50	6.70	6.60	J	0.46	0.56	0.51
A1	5.12	5.46	5.29	K	2.9 REF		
B	0.89	1.27	1.08	L	0.56	0.46	0.51
C	6.00	6.20	6.10	M	4.83 REF		
E	0.6	1.0	0.80	N	5.35 REF		
F	9.80	10.4	10.00	O	2.19	2.39	2.29
H	0.71	0.81	0.76	Q	0	0.10	0.05
I	2.20	2.38	2.29	R	1.40	1.70	1.55

APQ25SN06AB-XXF0
TO-252

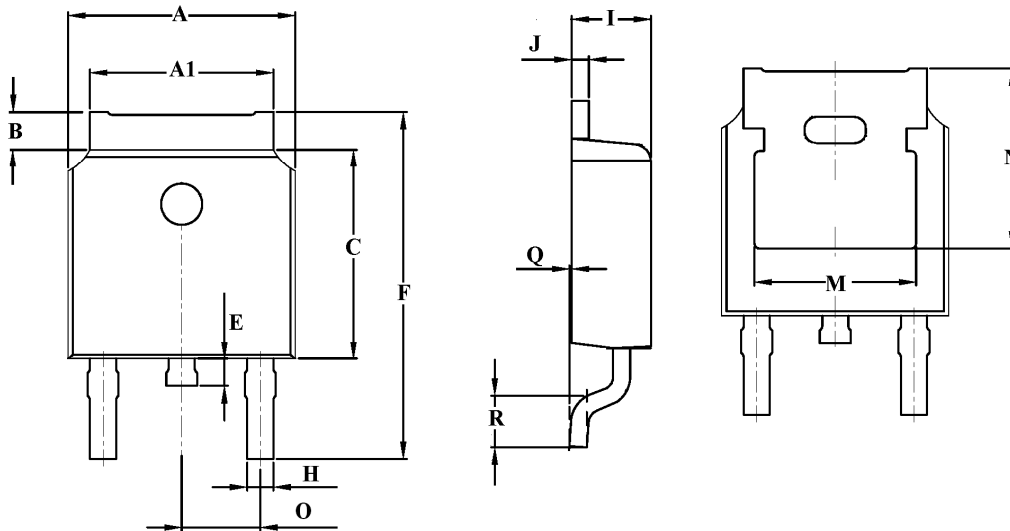

TO-252 DIMENSION							
DIM	MILLIMETERS						
	MIN	MAX	TYP.	DIM	MIN	MAX	TYP.
A	6.30	6.80	6.55	J	0.40	0.60	0.50
A1	4.50	5.50	5.00				
B	0.89	1.70	1.30				
C	5.20	6.23	5.70	M	4.83 REF		
E	0.50	1.10	0.80	N	5.35 REF		
F	9.40	10.50	10.00	O	2.19	2.39	2.29
H	0.50	0.88	0.70	Q	0	0.30	0.15
I	2.00	2.50	2.25	R	0.90	1.77	1.34



DEVICE SPECIFICATION

APQ25SN06AA
APQ25SN06AB

60V/25A N-Channel MOSFET

Note

The declared data are only a description of product, information furnished is believed to be accurate and reliable. However, alpha pacific assumes no responsibility for the consequences of use of such information nor for any infringement of patents or other rights of third parties which may result from its use. No license is granted by implication or otherwise under any patent or patent rights of alpha pacific. alpha pacific reserves the right to make changes on this specification without notice at any time.

This publication supersedes and replaces all information previously supplied. All alpha pacific products are not authorized for use as critical components in life support devices or systems, except by a written approval of alpha pacific.

Reprinting this data sheet - or parts of it - is only allowed with a license of alpha pacific.

contact

Alpha Pacific Technologies Co., Ltd
3F-6, No.18, Lane 609, Sec.5
Chung Sin road, Shan Chang District,
New Taipei City, TAIWAN, R.O.C

tel +886-2-2999 5456
fax +886-2-2999 5270
internet www.aptw.com