

**4.7A, 30V, 0.031 Ohm, N-Channel, Logic Level UltraFET Power MOSFET**



This N-Channel power MOSFET is manufactured using the innovative UltraFET process. This advanced process technology achieves the

lowest possible on-resistance per silicon area, resulting in outstanding performance. This device is capable of withstanding high energy in the avalanche mode and the diode exhibits very low reverse recovery time and stored charge. It was designed for use in applications where power efficiency is important, such as switching regulators, switching converters, motor drivers, relay drivers, low-voltage bus switches, and power management in portable and battery-operated products.

Formerly developmental type TA76113.

**Ordering Information**

PART NUMBER	PACKAGE	BRAND
HUF76113T3ST	SOT-223	76113

NOTE: HUF76113T3ST is available only in tape and reel.

**Features**

- Logic Level Gate Drive
- 4.7A, 30V
- Ultra Low On-Resistance,  $r_{DS(ON)} = 0.031\Omega$
- Temperature Compensating PSPICE® Model
- Temperature Compensating SABER™ Model
- Thermal Impedance SPICE Model
- Thermal Impedance SABER Model
- Peak Current vs Pulse Width Curve
- UIS Rating Curve
- Related Literature
  - TB334, "Guidelines for Soldering Surface Mount Components to PC Boards"

**Symbol**

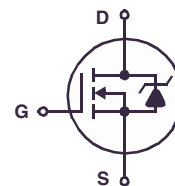

**Packaging**

SOT-223

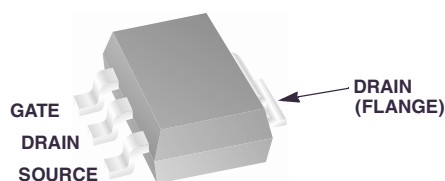

## HUF76113T3ST

### Absolute Maximum Ratings $T_A = 25^\circ\text{C}$ , Unless Otherwise Specified

	HUF76113T3ST	UNITS
Drain to Source Voltage (Note 1) . . . . .	$V_{DSS}$	30 V
Drain to Gate Voltage ( $R_{GS} = 20k\Omega$ ) (Note 1) . . . . .	$V_{DGR}$	30 V
Gate to Source Voltage . . . . .	$V_{GS}$	$\pm 20$ V
Drain Current		
Continuous ( $T_A = 25^\circ\text{C}$ , $V_{GS} = 10\text{V}$ ) (Figure 2) (Note 2) . . . . .	$I_D$	4.7 A
Continuous ( $T_A = 100^\circ\text{C}$ , $V_{GS} = 5\text{V}$ ) (Note 2) . . . . .	$I_D$	2.7 A
Continuous ( $T_A = 100^\circ\text{C}$ , $V_{GS} = 4.5\text{V}$ ) (Note 2) . . . . .	$I_D$	2.6 A
Pulsed Drain Current . . . . .	$I_{DM}$	Figure 4
Pulsed Avalanche Rating . . . . .	$E_{AS}$	Figure 6
Power Dissipation (Note 2) . . . . .	$P_D$	1.1 W
Derate Above $25^\circ\text{C}$ . . . . .		0.0091 $\text{W}/^\circ\text{C}$
Operating and Storage Temperature . . . . .	$T_J, T_{STG}$	-55 to 150 $^\circ\text{C}$
Maximum Temperature for Soldering		
Leads at 0.063in (1.6mm) from Case for 10s. . . . .	$T_L$	300 $^\circ\text{C}$
Package Body for 10s, See Techbrief 334 . . . . .	$T_{pkg}$	260 $^\circ\text{C}$

CAUTION: Stresses above those listed in "Absolute Maximum Ratings" may cause permanent damage to the device. This is a stress only rating and operation of the device at these or any other conditions above those indicated in the operational sections of this specification is not implied.

NOTE:

1.  $T_J = 25^\circ\text{C}$  to  $150^\circ\text{C}$ .

### Electrical Specifications $T_A = 25^\circ\text{C}$ , Unless Otherwise Specified

PARAMETER	SYMBOL	TEST CONDITIONS	MIN	TYP	MAX	UNITS
<b>OFF STATE SPECIFICATIONS</b>						
Drain to Source Breakdown Voltage	$BV_{DSS}$	$I_D = 250\mu\text{A}$ , $V_{GS} = 0\text{V}$ (Figure 12)	30	-	-	V
Zero Gate Voltage Drain Current	$I_{DSS}$	$V_{DS} = 25\text{V}$ , $V_{GS} = 0\text{V}$	-	-	1	$\mu\text{A}$
		$V_{DS} = 25\text{V}$ , $V_{GS} = 0\text{V}$ , $T_C = 150^\circ\text{C}$	-	-	250	$\mu\text{A}$
Gate to Source Leakage Current	$I_{GSS}$	$V_{GS} = \pm 20\text{V}$	-	-	$\pm 100$	nA
<b>ON STATE SPECIFICATIONS</b>						
Gate to Source Threshold Voltage	$V_{GS(TH)}$	$V_{GS} = V_{DS}$ , $I_D = 250\mu\text{A}$ (Figure 11)	1	-	3	V
Drain to Source On Resistance	$r_{DS(ON)}$	$I_D = 4.7\text{A}$ , $V_{GS} = 10\text{V}$ (Figure 9, 10)	-	0.027	0.031	$\Omega$
		$I_D = 2.7\text{A}$ , $V_{GS} = 5\text{V}$ (Figure 9)	-	0.033	0.038	$\Omega$
		$I_D = 2.6\text{A}$ , $V_{GS} = 4.5\text{V}$ (Figure 9)	-	0.035	0.040	$\Omega$
<b>THERMAL SPECIFICATIONS</b>						
Thermal Resistance Junction to Ambient	$R_{\theta JA}$	Pad Area = $0.173\text{ in}^2$ (Note 2)	-	-	110	$^\circ\text{C}/\text{W}$
		Pad Area = $0.068\text{ in}^2$ (See TB377)	-	-	133	$^\circ\text{C}/\text{W}$
		Pad Area = $0.026\text{ in}^2$ (See TB377)	-	-	157	$^\circ\text{C}/\text{W}$
<b>SWITCHING SPECIFICATIONS (<math>V_{GS} = 4.5\text{V}</math>)</b>						
Turn-On Time	$t_{ON}$	$V_{DD} = 15\text{V}$ , $I_D \cong 2.6\text{A}$ , $R_L = 5.8\Omega$ , $V_{GS} = 4.5\text{V}$ , $R_{GS} = 18\Omega$ (Figure 15)	-	-	90	ns
Turn-On Delay Time	$t_{d(ON)}$		-	12	-	ns
Rise Time	$t_r$		-	46	-	ns
Turn-Off Delay Time	$t_{d(OFF)}$		-	31	-	ns
Fall Time	$t_f$		-	31	-	ns
Turn-Off Time	$t_{OFF}$		-	-	-	95

## HUF76113T3ST

### Electrical Specifications $T_A = 25^\circ\text{C}$ , Unless Otherwise Specified

PARAMETER	SYMBOL	TEST CONDITIONS	MIN	TYP	MAX	UNITS	
<b>SWITCHING SPECIFICATIONS</b> ( $V_{GS} = 10\text{V}$ )							
Turn-On Time	$t_{ON}$	$V_{DD} = 15\text{V}$ , $I_D \cong 4.7\text{A}$ , $R_L = 3.2\Omega$ , $V_{GS} = 10\text{V}$ , $R_{GS} = 9.1\Omega$ (Figure 16)	-	-	40	ns	
Turn-On Delay Time	$t_{d(ON)}$		-	4	-	ns	
Rise Time	$t_r$		-	21	-	ns	
Turn-Off Delay Time	$t_{d(OFF)}$		-	31	-	ns	
Fall Time	$t_f$		-	25	-	ns	
Turn-Off Time	$t_{OFF}$		-	-	85	ns	
<b>GATE CHARGE SPECIFICATIONS</b>							
Total Gate Charge	$Q_{g(TOT)}$	$V_{GS} = 0\text{V to } 10\text{V}$	$V_{DD} = 15\text{V}$ , $I_D \cong 2.7\text{A}$ , $R_L = 5.5\Omega$ $I_{g(REF)} = 1.0\text{mA}$ (Figure 14)	-	17.0	20.5	nC
Gate Charge at 5V	$Q_{g(5)}$	$V_{GS} = 0\text{V to } 5\text{V}$		-	9.5	11.5	nC
Threshold Gate Charge	$Q_{g(TH)}$	$V_{GS} = 0\text{V to } 1\text{V}$		-	0.73	0.90	nC
Gate to Source Gate Charge	$Q_{gs}$			-	1.50	-	nC
Gate to Drain "Miller" Charge	$Q_{gd}$			-	4.30	-	nC
<b>CAPACITANCE SPECIFICATIONS</b>							
Input Capacitance	$C_{ISS}$	$V_{DS} = 25\text{V}$ , $V_{GS} = 0\text{V}$ , $f = 1\text{MHz}$ (Figure 13)	-	625	-	pF	
Output Capacitance	$C_{OSS}$		-	310	-	pF	
Reverse Transfer Capacitance	$C_{RSS}$		-	60	-	pF	

**NOTES:**

- Rated with  $R_{\theta JA} = 110^\circ\text{C/W}$  measured using FR-4 board with 0.173 in<sup>2</sup> copper at 1000 seconds.

### Source to Drain Diode Specifications

PARAMETER	SYMBOL	TEST CONDITIONS	MIN	TYP	MAX	UNITS
Source to Drain Diode Voltage	$V_{SD}$	$I_{SD} = 4.7\text{A}$	-	-	1.25	V
		$I_{SD} = 2.7\text{A}$	-	-	1.00	V
Reverse Recovery Time	$t_{rr}$	$I_{SD} = 2.7\text{A}$ , $dI_{SD}/dt = 100\text{A}/\mu\text{s}$	-	-	44	ns
Reverse Recovered Charge	$Q_{RR}$	$I_{SD} = 2.7\text{A}$ , $dI_{SD}/dt = 100\text{A}/\mu\text{s}$	-	-	46	nC

### Typical Performance Curves

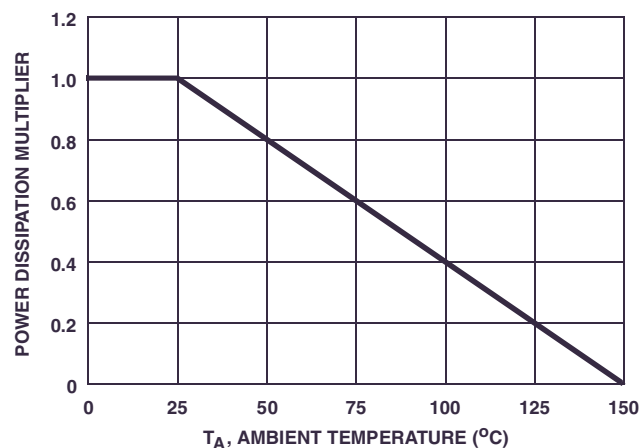

FIGURE 1. NORMALIZED POWER DISSIPATION vs AMBIENT TEMPERATURE

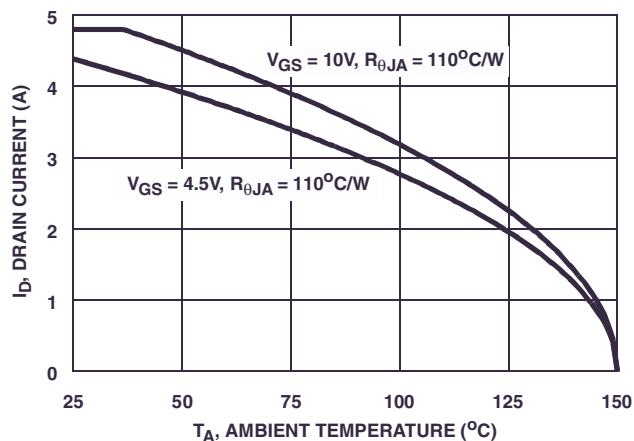

FIGURE 2. MAXIMUM CONTINUOUS DRAIN CURRENT vs AMBIENT TEMPERATURE

# HUF76113T3ST

## Typical Performance Curves (Continued)

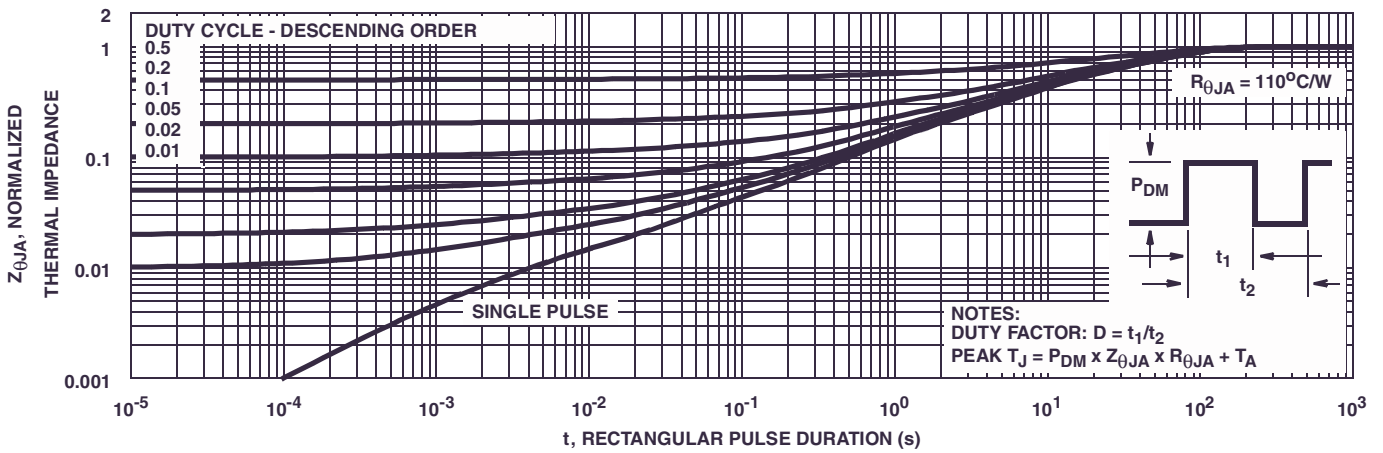

FIGURE 3. NORMALIZED MAXIMUM TRANSIENT THERMAL IMPEDANCE

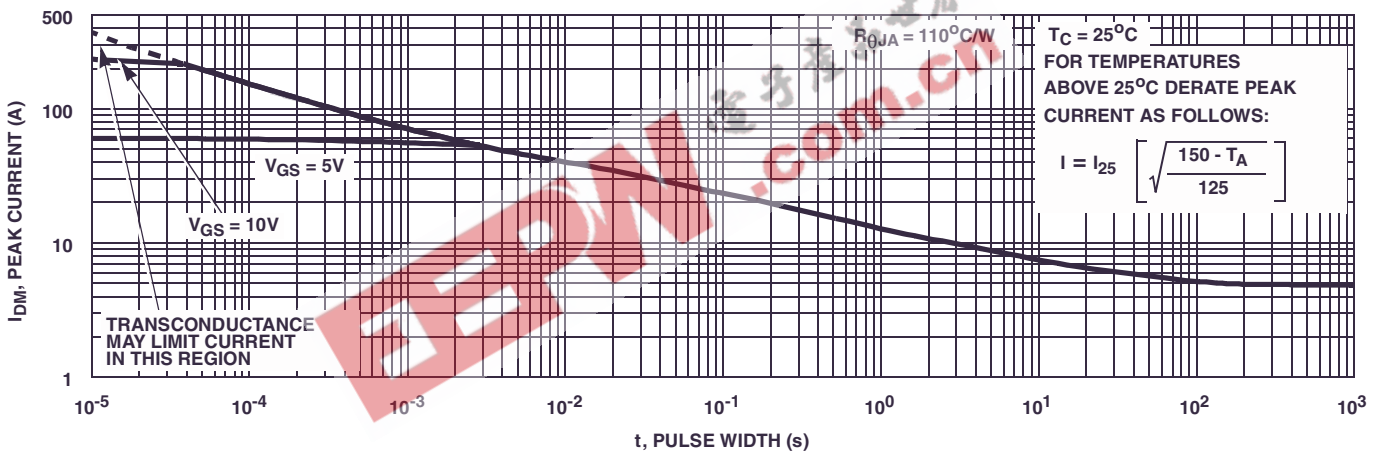

FIGURE 4. PEAK CURRENT CAPABILITY

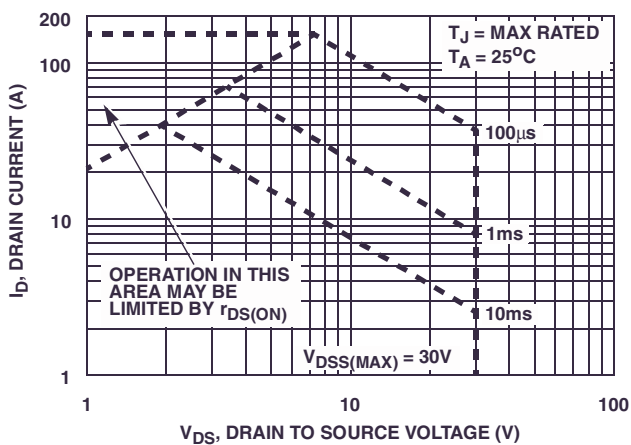
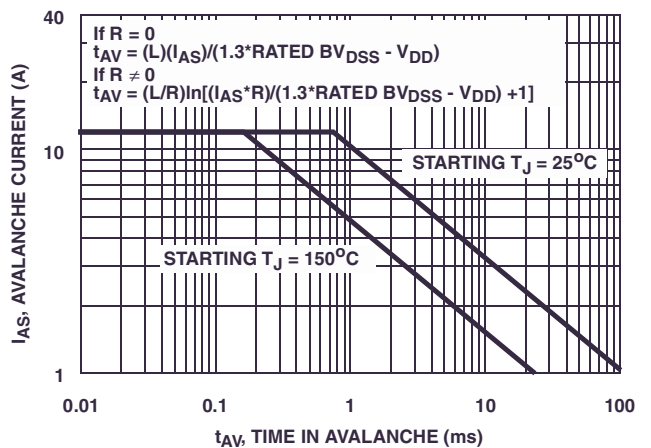

FIGURE 5. FORWARD BIAS SAFE OPERATING AREA



NOTE: Refer to Fairchild Application Notes AN9321 and AN9322.

FIGURE 6. UNCLAMPED INDUCTIVE SWITCHING CAPABILITY

Typical Performance Curves (Continued)

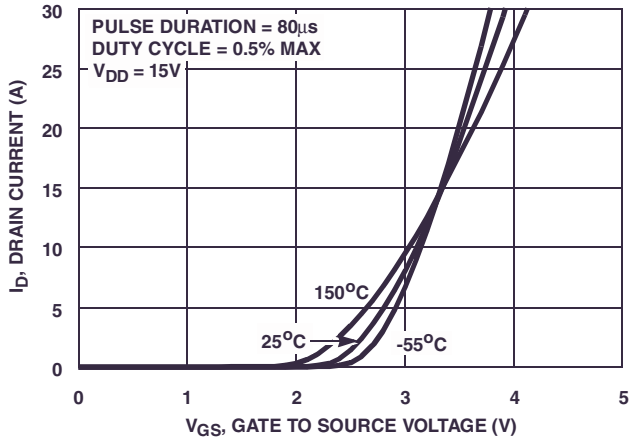

FIGURE 7. TRANSFER CHARACTERISTICS

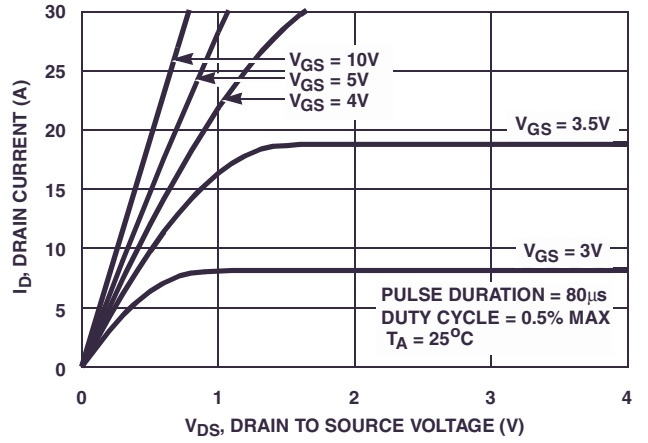

FIGURE 8. SATURATION CHARACTERISTICS

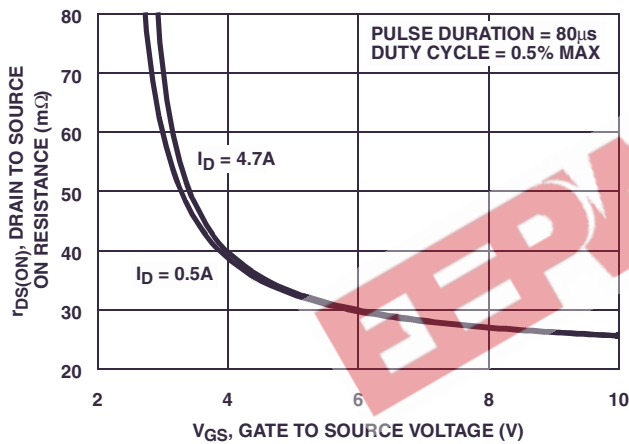

FIGURE 9. DRAIN TO SOURCE ON RESISTANCE vs GATE VOLTAGE AND DRAIN CURRENT

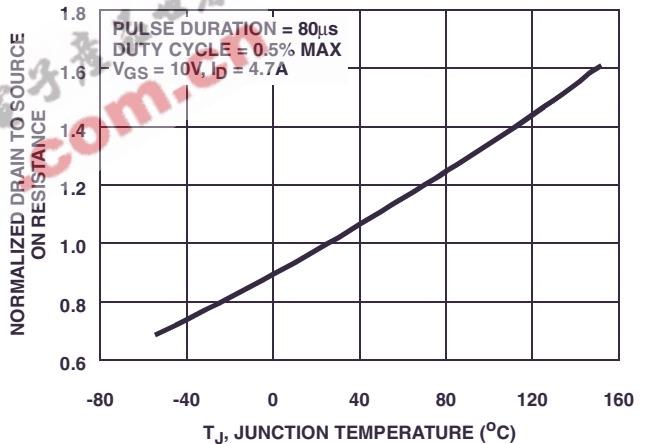

FIGURE 10. NORMALIZED DRAIN TO SOURCE ON RESISTANCE vs JUNCTION TEMPERATURE

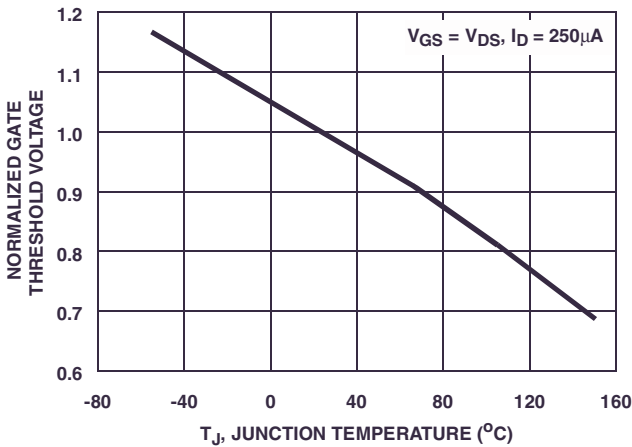

FIGURE 11. NORMALIZED GATE THRESHOLD VOLTAGE vs JUNCTION TEMPERATURE

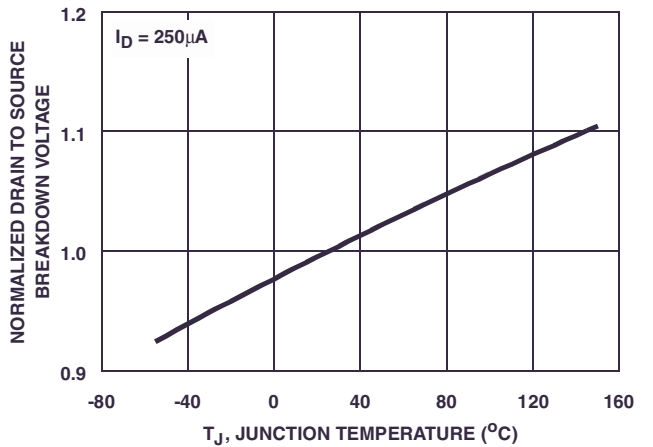

FIGURE 12. NORMALIZED DRAIN TO SOURCE BREAKDOWN VOLTAGE vs JUNCTION TEMPERATURE

Typical Performance Curves (Continued)

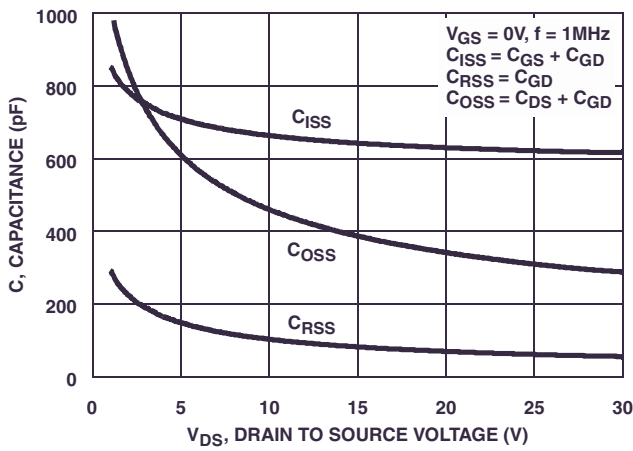
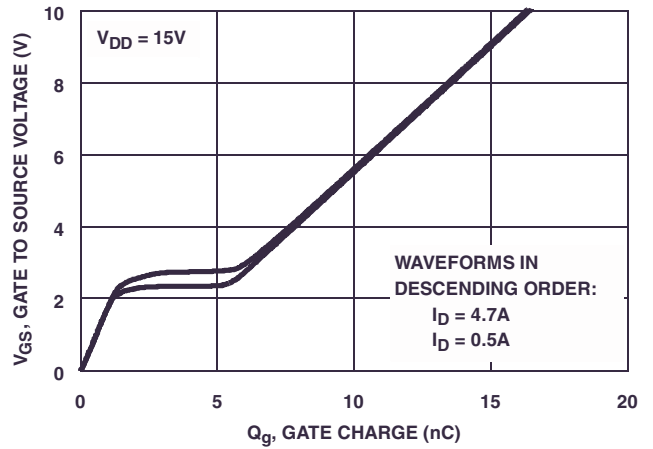

FIGURE 13. CAPACITANCE vs DRAIN TO SOURCE VOLTAGE



NOTE: Refer to Fairchild Application Notes AN7254 and AN7260.

FIGURE 14. GATE CHARGE WAVEFORMS FOR CONSTANT GATE CURRENT

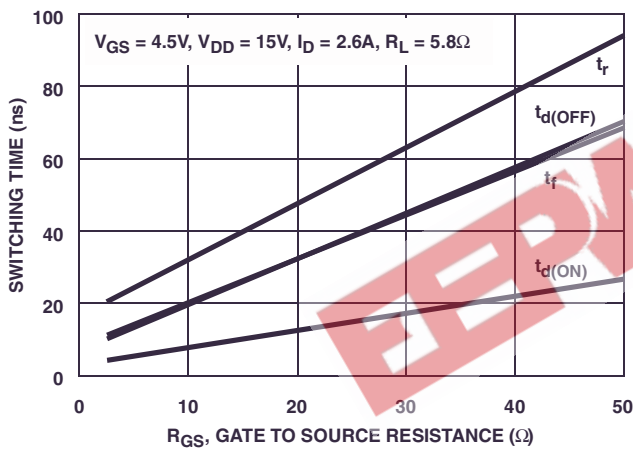

FIGURE 15. SWITCHING TIME vs GATE RESISTANCE

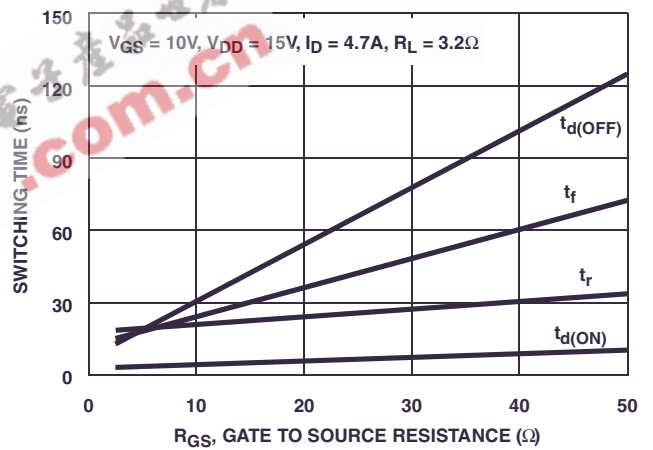

FIGURE 16. SWITCHING TIME vs GATE RESISTANCE

Test Circuits and Waveforms

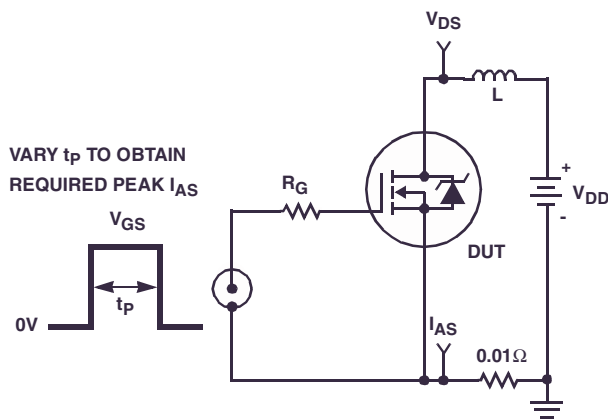

FIGURE 17. UNCLAMPED ENERGY TEST CIRCUIT

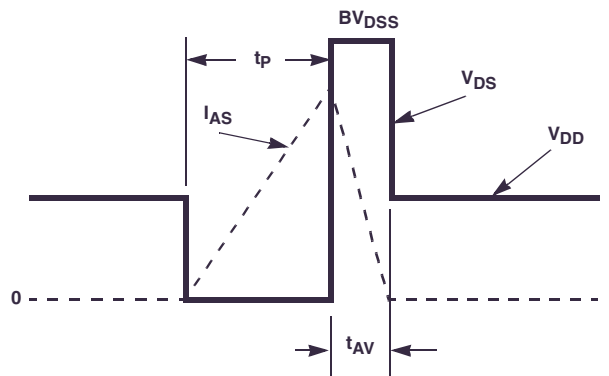

FIGURE 18. UNCLAMPED ENERGY WAVEFORMS

Test Circuits and Waveforms (Continued)

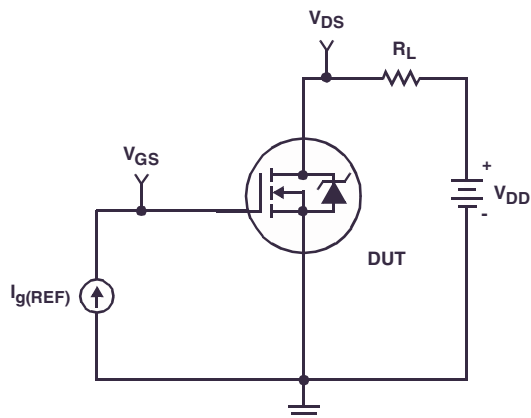

FIGURE 19. GATE CHARGE TEST CIRCUIT

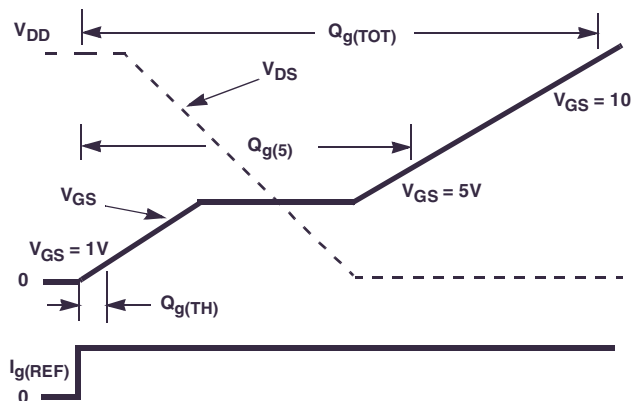

FIGURE 20. GATE CHARGE WAVEFORMS

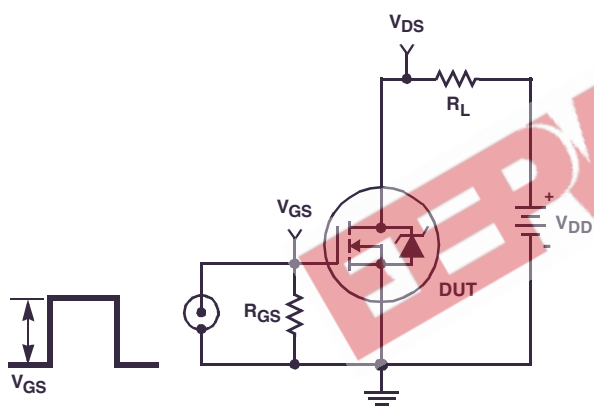

FIGURE 21. SWITCHING TIME TEST CIRCUIT

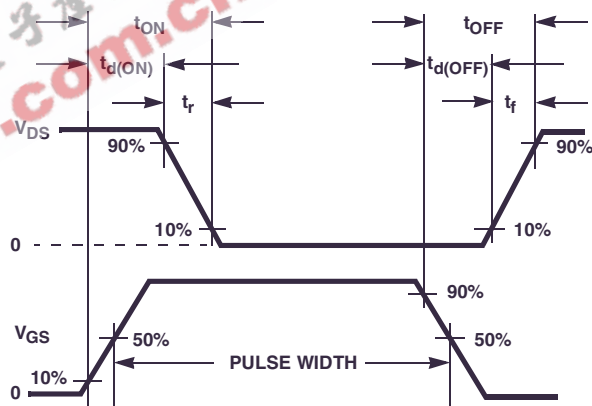

FIGURE 22. SWITCHING TIME WAVEFORM

**Thermal Resistance vs. Mounting Pad Area**

The maximum rated junction temperature,  $T_{JM}$ , and the thermal resistance of the heat dissipating path determines the maximum allowable device power dissipation,  $P_{DM}$ , in an application. Therefore the application's ambient temperature,  $T_A$  ( $^{\circ}C$ ), and thermal resistance  $R_{\theta JA}$  ( $^{\circ}C/W$ ) must be reviewed to ensure that  $T_{JM}$  is never exceeded. Equation 1 mathematically represents the relationship and serves as the basis for establishing the rating of the part.

$$P_{DM} = \frac{(T_{JM} - T_A)}{Z_{\theta JA}} \quad (EQ. 1)$$

In using surface mount devices such as the SOT-223 package, the environment in which it is applied will have a significant influence on the part's current and maximum power dissipation ratings. Precise determination of  $P_{DM}$  is complex and influenced by many factors:

1. Mounting pad area onto which the device is attached and whether there is copper on one side or both sides of the board.
2. The number of copper layers and the thickness of the board.
3. The use of external heat sinks.
4. The use of thermal vias.
5. Air flow and board orientation.
6. For non steady state applications, the pulse width, the duty cycle and the transient thermal response of the part, the board and the environment they are in.

## HUF76113T3ST

Fairchild provides thermal information to assist the designer's preliminary application evaluation. Figure 23 defines the  $R_{\theta JA}$  for the device as a function of the top copper (component side) area. This is for a horizontally positioned FR-4 board with 1oz copper after 1000 seconds of steady state power with no air flow. This graph provides the necessary information for calculation of the steady state junction temperature or power dissipation. Pulse applications can be evaluated using the Fairchild device Spice thermal model or manually utilizing the normalized maximum transient thermal impedance curve. Displayed on the curve are  $R_{\theta JA}$  values listed in the Electrical Specifications table. The points were chosen to depict the compromise between the copper board area, the thermal resistance and ultimately the power dissipation,  $P_{DM}$ . The smallest areas represent

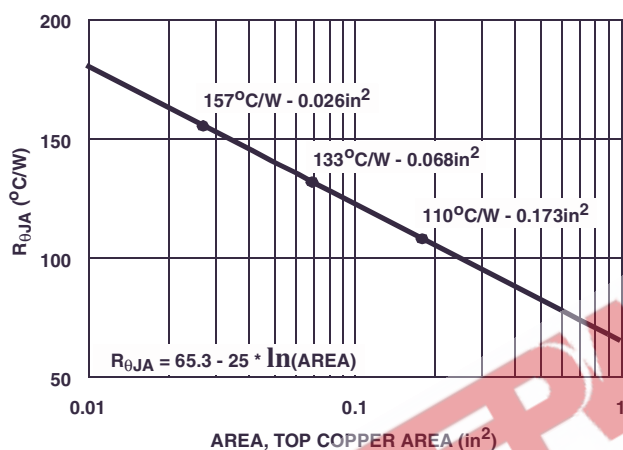

FIGURE 23. THERMAL RESISTANCE vs MOUNTING PAD AREA

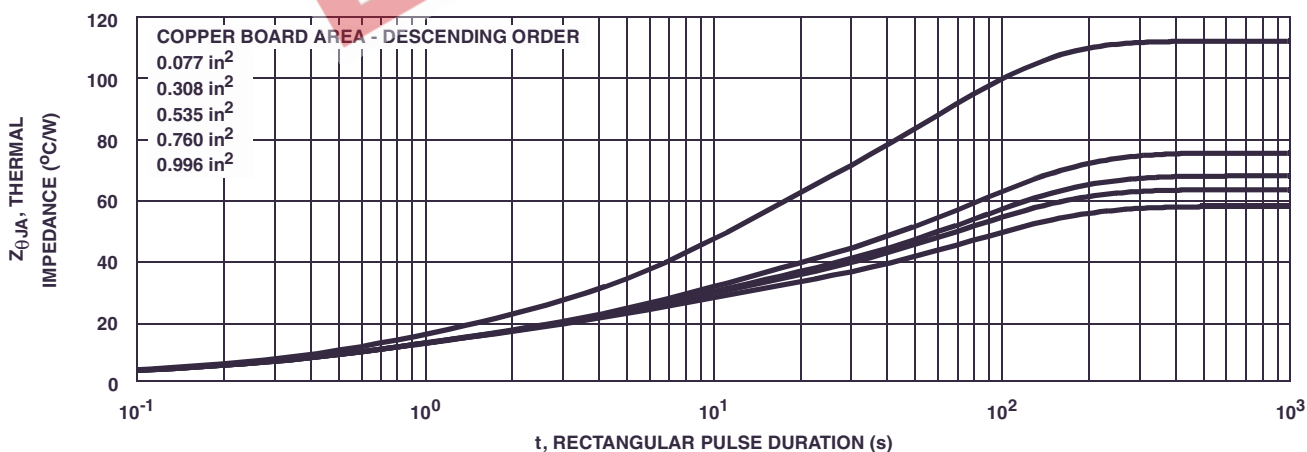

FIGURE 24. THERMAL IMPEDANCE vs MOUNTING PAD AREA

the minimum bond pad area and the package outline area respectively as determined from the package diagram

Thermal resistances corresponding to other copper areas can be obtained from Figure 23 or by calculation using Equation 2.  $R_{\theta JA}$  is defined as the natural log of the area times a coefficient added to a constant. The area, in square inches is the top copper area including the gate and source pads.

$$R_{\theta JA} = 65.3 - 25 \times \ln(\text{Area}) \quad (\text{EQ. 2})$$

The transient thermal impedance ( $Z_{\theta JA}$ ) is also effected by varied top copper board area. Figure 24 shows the effect of copper pad area on single pulse transient thermal impedance. Each trace represents a copper pad area in square inches corresponding to the descending list in the graph. Spice and SABER thermal models are provided for each of the listed pad areas.

Copper pad area has no perceivable effect on transient thermal impedance for pulse widths less than 100ms. For pulse widths less than 100ms the transient thermal impedance is determined by the die and package. Therefore, C THERM1 through C THERM5 and R THERM1 through R THERM5 remain constant for each of the thermal models. A listing of the model component values is available in Table 1.



# HUF76113T3ST

## PSPICE Electrical Model

.SUBCKT HUF76113T3 2 1 3 ; REV August 1998

CA 12 8 8.7e-10  
 CB 15 14 8.7e-10  
 CIN 6 8 5.6e-10

DBODY 7 5 DBODYMOD  
 DBREAK 5 11 DBREAKMOD  
 DPLCAP 10 5 DPLCAPMOD

EBREAK 11 7 17 18 34.3  
 EDS 14 8 5 8 1  
 EGS 13 8 6 8 1  
 ESG 6 10 6 8 1  
 EVTHRES 6 21 19 8 1  
 EVTEMP 20 6 18 22 1

IT 8 17 1

LDRAIN 2 5 1e-9  
 LGATE 1 9 1.69e-9  
 LSOURCE 3 7 4.1e-10

MMED 16 6 8 8 MMEDMOD  
 MSTRO 16 6 8 8 MSTROMOD  
 MWEAK 16 21 8 8 MWEAKMOD

RBREAK 17 18 RBREAKMOD 1  
 RDRAIN 50 16 RDRAINMOD 9.2e-3  
 RGATE 9 20 2.5  
 RLDRAIN 2 5 10  
 RLGATE 1 9 16.9  
 RLSOURCE 3 7 4.1  
 RSLC1 5 51 RSLCMOD 1e-6  
 RSLC2 5 50 1e3  
 RSOURCE 8 7 RSOURCEMOD 12.5e-3  
 RVTHRES 22 8 RVTHRESMOD 1  
 RVTEMP 18 19 RVTEMPMOD 1

S1A 6 12 13 8 S1AMOD  
 S1B 13 12 13 8 S1BMOD  
 S2A 6 15 14 13 S2AMOD  
 S2B 13 15 14 13 S2BMOD

VBAT 22 19 DC 1

ESLC 51 50 VALUE={{(V(5,51)/ABS(V(5,51)))\*(PWR(V(5,51))/(1e-6\*180),2.5)}}

.MODEL DBODYMOD D (IS = 9.35e-13 RS = 1.39e-2 TRS1 = 1.12e-6 TRS2 = 1.05e-6 CJO = 9.85e-10 TT = 2.82e-8 M = 0.42)  
 .MODEL DBREAKMOD D (RS = 1.5e-1 TRS1 = 3.51e-3 TRS2 = -5e-5)  
 .MODEL DPLCAPMOD D (CJO = 4.4e-10 IS = 1e-30 N = 10 M = 0.6)  
 .MODEL MMEDMOD NMOS (VTO = 1.95 KP = 3.55 IS = 1e-30 N = 10 TOX = 1 L = 1u W = 1u RG = 2.5)  
 .MODEL MSTROMOD NMOS (VTO = 2.23 KP = 29 IS = 1e-30 N = 10 TOX = 1 L = 1u W = 1u)  
 .MODEL MWEAKMOD NMOS (VTO = 1.68 KP = 0.095 IS = 1e-30 N = 10 TOX = 1 L = 1u W = 1u RG = 25 RS = 0.1)  
 .MODEL RBREAKMOD RES (TC1 = 9.7e-4 TC2 = -5e-7)  
 .MODEL RDRAINMOD RES (TC1 = 5.8e-3 TC2 = 1.12e-5)  
 .MODEL RSLCMOD RES (TC1 = -9.92e-3 TC2 = -2.06e-5)  
 .MODEL RSOURCEMOD RES (TC1 = 3e-3 TC2 = 0)  
 .MODEL RVTHRESMOD RES (TC = -1.2e-3 TC2 = -5.42e-6)  
 .MODEL RVTEMPMOD RES (TC1 = -1.9e-3 TC2 = 1e-6)

.MODEL S1AMOD VSWITCH (RON = 1e-5 ROFF = 0.1 VON = -7.0 VOFF = -1.5)  
 .MODEL S1BMOD VSWITCH (RON = 1e-5 ROFF = 0.1 VON = -1.5 VOFF = -7.0)  
 .MODEL S2AMOD VSWITCH (RON = 1e-5 ROFF = 0.1 VON = -0.8 VOFF = 0.6)  
 .MODEL S2BMOD VSWITCH (RON = 1e-5 ROFF = 0.1 VON = 0.6 VOFF = -0.8)

.ENDS

NOTE: For further discussion of the PSPICE model, consult **A New PSPICE Sub-Circuit for the Power MOSFET Featuring Global Temperature Options**; IEEE Power Electronics Specialist Conference Records, 1991, written by William J. Hepp and C. Frank Wheatley.

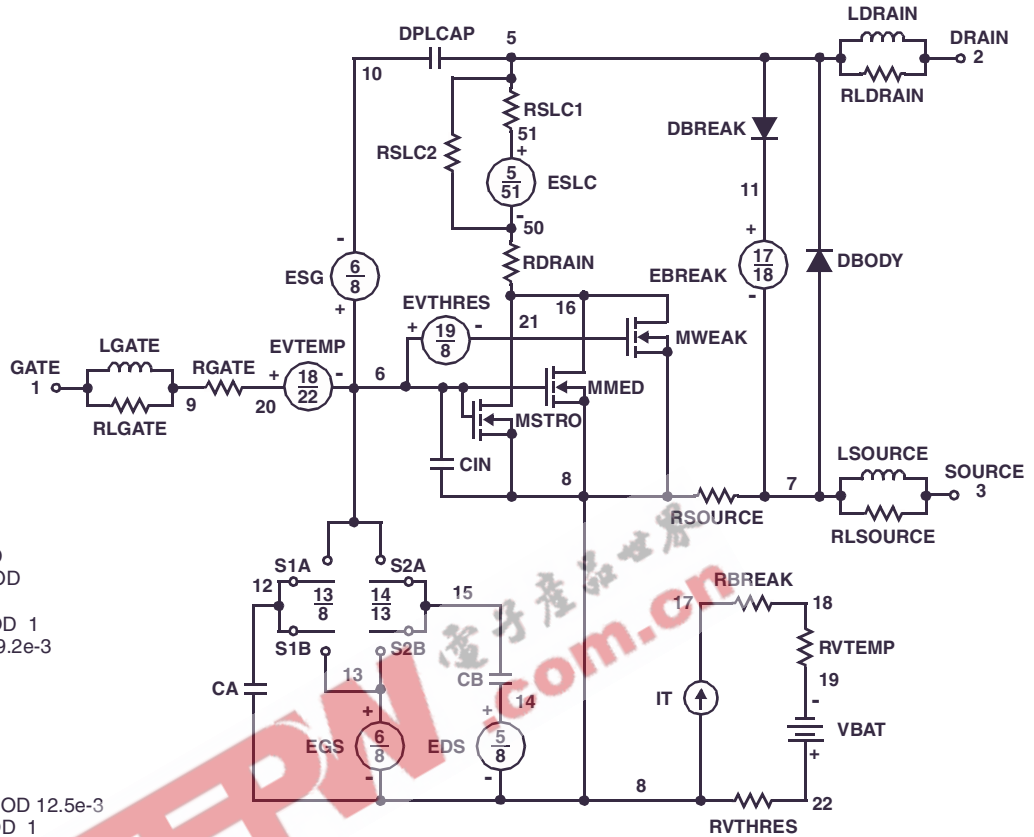

# HUF76113T3ST

## SABER Electrical Model

REV October 1998

template huf76113T3 n2,n1,n3  
electrical n2,n1,n3

```
{
var i iscl
d..model dbodymod = (is = 9.35e-13, cjo = 9.85e-10, tt = 2.82e-8, m = 0.42)
d..model dbreakmod = ()
d..model dplcapmod = (cjo = 4.4e-10, is = 1e-30, n = 10, m = 0.6)
m..model mmedmod = (type=_n, vto = 1.95, kp = 3.55, is = 1e-30, tox = 1)
m..model mstrongmod = (type=_n, vto = 2.23, kp = 29, is = 1e-30, tox = 1)
m..model mweakmod = (type=_n, vto = 1.68, kp = 0.095, is = 1e-30, tox = 1)
sw_vcsp..model s1amod = (ron = 1e-5, roff = 0.1, von = -7.0, voff = -1.5)
sw_vcsp..model s1bmod = (ron = 1e-5, roff = 0.1, von = -1.5, voff = -7.0)
sw_vcsp..model s2amod = (ron = 1e-5, roff = 0.1, von = -0.8, voff = 0.6)
sw_vcsp..model s2bmod = (ron = 1e-5, roff = 0.1, von = 0.6, voff = -0.8)
```

```
c.ca n12 n8 = 8.7e-10
c.cb n15 n14 = 8.7e-10
c.cin n6 n8 = 5.6e-10
```

```
d.body n7 n71 = model=dbodymod
d.break n72 n11 = model=dbreakmod
d.dplcap n10 n5 = model=dplcapmod
```

```
i.it n8 n17 = 1
```

```
l.drain n2 n5 = 1e-9
l.gate n1 n9 = 1.69e-9
l.source n3 n7 = 4.1e-10
```

```
m.mmed n16 n6 n8 n8 = model=mmedmod, l=1u, w=1u
m.mstrong n16 n6 n8 n8 = model=mstrongmod, l=1u, w=1u
m.mweak n16 n21 n8 n8 = model=mweakmod, l=1u, w=1u
```

```
res.rbreak n17 n18 = 1, tc1 = 9.7e-4, tc2 = -5e-7
res.rbody n71 n5 = 1.39e-2, tc1 = 1.12e-6, tc2 = 1.05e-6
res.rdbreak n72 n5 = 1.5e-1, tc1 = 3.51e-3, tc2 = -5e-5
res.rdrain n50 n16 = 9.2e-3, tc1 = 5.8e-3, tc2 = 1.12e-5
res.rgate n9 n20 = 2.5
res.rldrain n2 n5 = 10
res.rlgate n1 n9 = 16.9
res.rlsource n3 n7 = 4.1
res.rslc1 n5 n51 = 1e-6, tc1 = -9.92e-3, tc2 = -2.06e-5
res.rslc2 n5 n50 = 1e3
res.rsource n8 n7 = 12.5e-3, tc1 = 3e-3, tc2 = 0
res.rvtemp n18 n19 = 1, tc1 = -1.9e-3, tc2 = 1e-6
res.rvthres n22 n8 = 1, tc1 = -1.2e-3, tc2 = -5.42e-6
```

```
spe.ebreak n11 n7 n17 n18 = 34.3
spe.eds n14 n8 n5 n8 = 1
spe.egs n13 n8 n6 n8 = 1
spe.esg n6 n10 n6 n8 = 1
spe.evtemp n20 n6 n18 n22 = 1
spe.evthres n6 n21 n19 n8 = 1
```

```
sw_vcsp.s1a n6 n12 n13 n8 = model=s1amod
sw_vcsp.s1b n13 n12 n13 n8 = model=s1bmod
sw_vcsp.s2a n6 n15 n14 n13 = model=s2amod
sw_vcsp.s2b n13 n15 n14 n13 = model=s2bmod
```

```
v.vbat n22 n19 = dc=1
```

```
equations {
i (n51->n50) +=iscl
iscl: v(n51,n50) = ((v(n5,n51))/(1e-9+abs(v(n5,n51))))*((abs(v(n5,n51))*1e6/180)** 2.5)
}
}
```

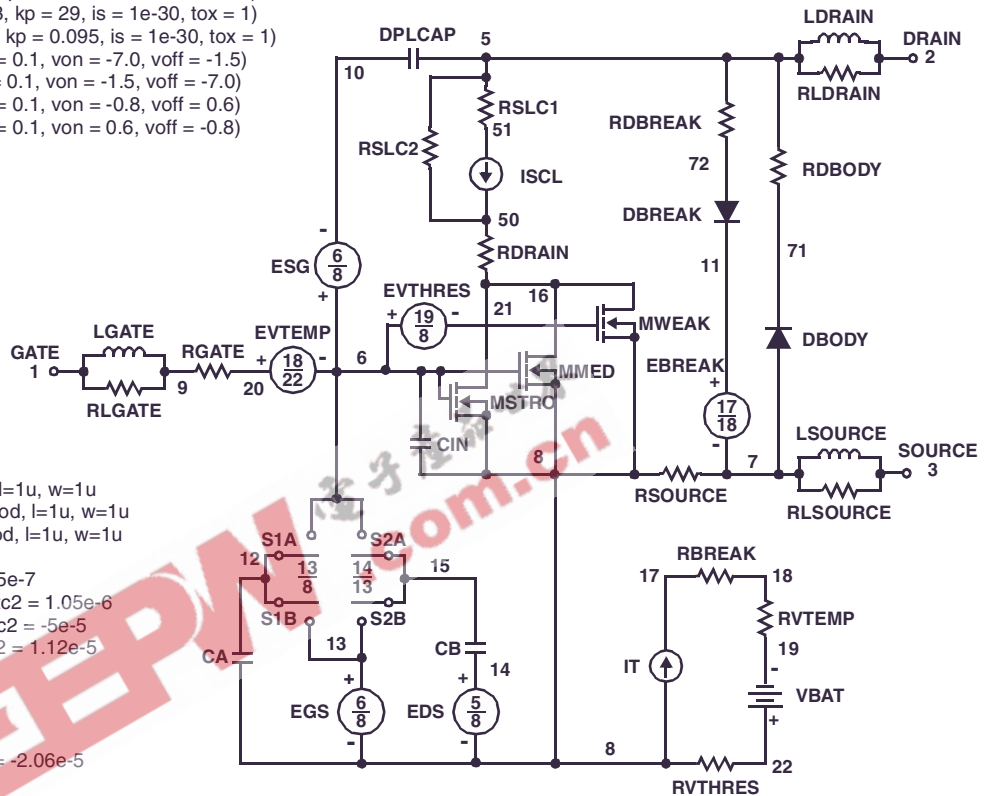

# HUF76113T3ST

## SPICE Thermal Model

REV August 1998

HUF76113T3ST

Copper Area = 0.077 in<sup>2</sup>

CTHERM1 th 8 1.9e-5

CTHERM2 8 7 9.5e-4

CTHERM3 7 6 1.9e-3

CTHERM4 6 5 3.5e-3

CTHERM5 5 4 2.0e-2

CTHERM6 4 3 6.5e-2

CTHERM7 3 2 2.4e-1

CTHERM8 2 tl 9.0e-1

RTHERM1 th 8 3.5e-3

RTHERM2 8 7 3.1e-2

RTHERM3 7 6 2.0e-1

RTHERM4 6 5 8.0e-1

RTHERM5 5 4 2.1

RTHERM6 4 3 11

RTHERM7 3 2 32

RTHERM8 2 tl 66

## SABER Thermal Model

Copper Area = 0.077 in<sup>2</sup>

template thermal\_model th tl

thermal\_c th, tl

```
{
ctherm.ctherm1 th 8 = 1.9e-5
ctherm.ctherm2 8 7 = 9.5e-4
ctherm.ctherm3 7 6 = 1.9e-3
ctherm.ctherm4 6 5 = 3.5e-3
ctherm.ctherm5 5 4 = 2.0e-2
ctherm.ctherm6 4 3 = 6.5e-2
ctherm.ctherm7 3 2 = 2.4e-1
ctherm.ctherm8 2 tl = 9.0e-1
```

```
rtherm.rtherm1 th 8 = 3.5e-3
rtherm.rtherm2 8 7 = 3.1e-2
rtherm.rtherm3 7 6 = 2.0e-1
rtherm.rtherm4 6 5 = 8.0e-1
rtherm.rtherm5 5 4 = 2.1
rtherm.rtherm6 4 3 = 11
rtherm.rtherm7 3 2 = 32
rtherm.rtherm8 2 tl = 66
```

}

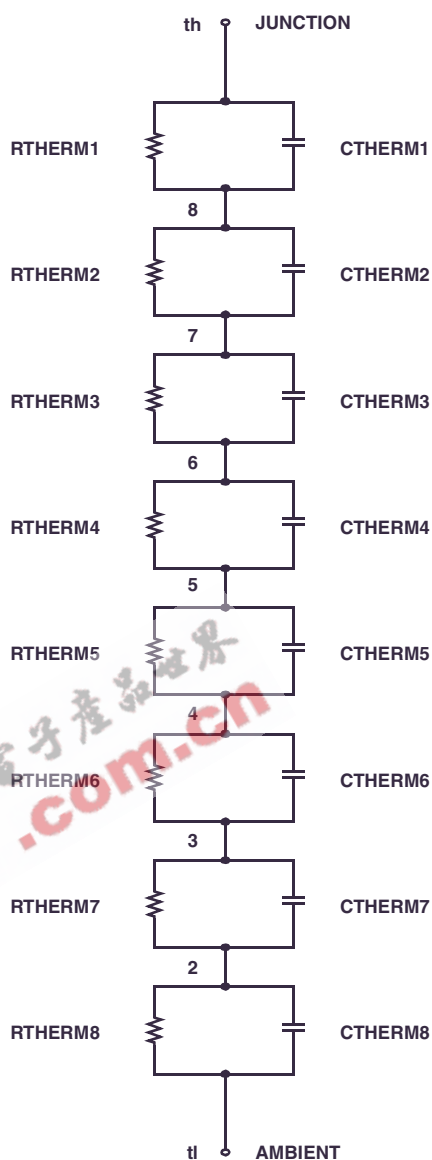

TABLE 1. THERMAL MODELS

COMPONENT	0.077 in <sup>2</sup>	0.308 in <sup>2</sup>	0.535 in <sup>2</sup>	0.76 in <sup>2</sup>	0.996 in <sup>2</sup>
CTHERM6	6.5e-2	6.7e-2	6.7e-2	6.7e-2	6.7e-2
CTHERM7	2.4e-1	3.5e-1	3.5e-1	3.5e-1	3.5e-1
CTHERM8	9.0e-1	1.7	1.9	2	2.4
RTHERM6	11	9	9	9	9
RTHERM7	32	18	16	15.5	14.5
RTHERM8	66	45.5	40	36	31.5

## TRADEMARKS

The following are registered and unregistered trademarks Fairchild Semiconductor owns or is authorized to use and is not intended to be an exhaustive list of all such trademarks.

ACEx™	FACT™	ImpliedDisconnect™	PACMAN™	SPM™
ActiveArray™	FACT Quiet Series™	ISOPLANAR™	POP™	Stealth™
Bottomless™	FAST®	LittleFET™	Power247™	SuperSOT™-3
CoolFET™	FASTr™	MicroFET™	PowerTrench®	SuperSOT™-6
CROSSVOLT™	FRFET™	MicroPak™	QFET™	SuperSOT™-8
DOME™	GlobalOptoisolator™	MICROWIRE™	QST™	SyncFET™
EcoSPARK™	GTO™	MSX™	QT Optoelectronics™	TinyLogic®
E <sup>2</sup> C MOS™	HiSeC™	MSXPro™	Quiet Series™	TruTranslation™
EnSigna™	I <sup>2</sup> C™	OCX™	RapidConfigure™	UHC™
Across the board. Around the world.™		OCXPro™	RapidConnect™	UltraFET®
The Power Franchise™		OPTOLOGIC®	SILENT SWITCHER®	VCX™
Programmable Active Droop™		OPTOPLANAR™	SMART START™	

## DISCLAIMER

FAIRCHILD SEMICONDUCTOR RESERVES THE RIGHT TO MAKE CHANGES WITHOUT FURTHER NOTICE TO ANY PRODUCTS HEREIN TO IMPROVE RELIABILITY, FUNCTION OR DESIGN. FAIRCHILD DOES NOT ASSUME ANY LIABILITY ARISING OUT OF THE APPLICATION OR USE OF ANY PRODUCT OR CIRCUIT DESCRIBED HEREIN; NEITHER DOES IT CONVEY ANY LICENSE UNDER ITS PATENT RIGHTS, NOR THE RIGHTS OF OTHERS.

## LIFE SUPPORT POLICY

FAIRCHILD'S PRODUCTS ARE NOT AUTHORIZED FOR USE AS CRITICAL COMPONENTS IN LIFE SUPPORT DEVICES OR SYSTEMS WITHOUT THE EXPRESS WRITTEN APPROVAL OF FAIRCHILD SEMICONDUCTOR CORPORATION.

As used herein:

1. Life support devices or systems are devices or systems which, (a) are intended for surgical implant into the body, or (b) support or sustain life, or (c) whose failure to perform when properly used in accordance with instructions for use provided in the labeling, can be reasonably expected to result in significant injury to the user.
2. A critical component is any component of a life support device or system whose failure to perform can be reasonably expected to cause the failure of the life support device or system, or to affect its safety or effectiveness.

## PRODUCT STATUS DEFINITIONS

### Definition of Terms

Datasheet Identification	Product Status	Definition
Advance Information	Formative or In Design	This datasheet contains the design specifications for product development. Specifications may change in any manner without notice.
Preliminary	First Production	This datasheet contains preliminary data, and supplementary data will be published at a later date. Fairchild Semiconductor reserves the right to make changes at any time without notice in order to improve design.
No Identification Needed	Full Production	This datasheet contains final specifications. Fairchild Semiconductor reserves the right to make changes at any time without notice in order to improve design.
Obsolete	Not In Production	This datasheet contains specifications on a product that has been discontinued by Fairchild Semiconductor. The datasheet is printed for reference information only.