

N-Channel Enhancement-Mode MOSFET

V_{DS} 30V $R_{DS(ON)}$ 13mΩ I_D 50A

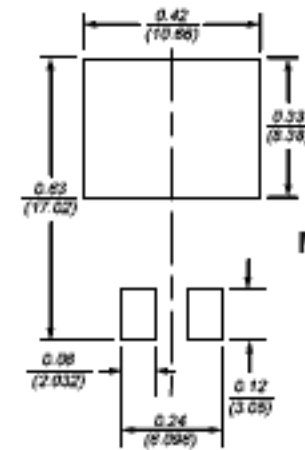

TO-263AB

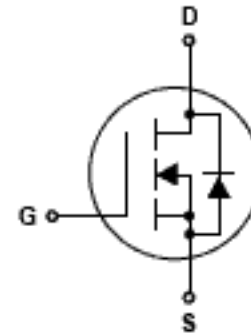
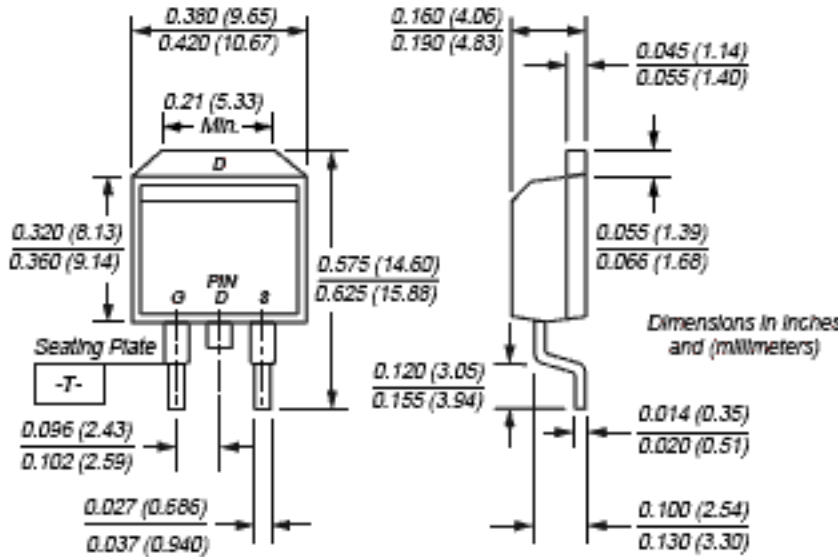

Mechanical Data

Case: JEDEC TO-263 molded plastic body
 Terminals: Leads solderable per MIL-STD-750, Method 2028
 High temperature soldering guaranteed: 250°C/10 seconds at terminals
 Mounting Position: Any Weight: 1.3g

Features

- Advanced Trench Process Technology
- High Density Cell Design for Ultra Low On-Resistance
- Specially Designed for Low Voltage DC/DC Converters
- Fast Switching for High Efficiency

Maximum Ratings and Thermal Characteristics ($T_C = 25^\circ\text{C}$ unless otherwise noted)

Parameter	Symbol	Limit	Unit
Drain-Source Voltage	V_{DS}	30	V
Gate-Source Voltage	V_{GS}	± 20	
Continuous Drain Current ⁽¹⁾	I_D	50	A
Pulsed Drain Current	I_{DM}	100	
Maximum Power Dissipation	P_D	62.5 25	W
		$T_C = 25^\circ\text{C}$ $T_C = 100^\circ\text{C}$	
Operating Junction and Storage Temperature Range	T_J, T_{stg}	-55 to 150	$^\circ\text{C}$
Lead Temperature (1/8" from case for 5 sec.)	T_L	275	$^\circ\text{C}$
Junction-to-Case Thermal Resistance	$R_{\theta JC}$	2.0	$^\circ\text{C/W}$
Junction-to-Ambient Thermal Resistance ⁽²⁾	$R_{\theta JA}$	40	$^\circ\text{C/W}$

Notes: (1) Maximum DC current limited by the package
 (2) 1-in² 2oz. Cu PCB mounted

N-Channel Enhancement-Mode MOSFET

Electrical Characteristics (T_J = 25°C unless otherwise noted)

Parameter	Symbol	Test Condition	Min	Typ	Max	Unit	
Static							
Drain-Source Breakdown Voltage	BV _{DSS}	V _{GS} = 0V, I _D = 250μA	30			V	
Gate Threshold Voltage	V _{GS(th)}	V _{DS} = V _{GS} , I _D = 250μA	1.0		3.0	V	
Gate-Body Leakage	I _{GSS}	V _{DS} = 0V, V _{GS} = ±20V			±100	nA	
Zero Gate Voltage Drain Current	I _{DSS}	V _{DS} = 30V, V _{GS} = 0V			1	μA	
On-State Drain Current ⁽¹⁾	I _{D(on)}	V _{DS} ≥ 5V, V _{GS} = 10V	60			A	
Drain-Source On-State Resistance ⁽¹⁾	R _{DS(on)}	V _{GS} = 10V, I _D = 25A		11	13	mΩ	
		V _{GS} = 4.5V, I _D = 20A		15	20		
Forward Transconductance ⁽¹⁾	g _{fs}	V _{DS} = 10V, I _D = 25A		40		S	
Diode Forward Voltage	V _{SD}	I _S = 25A, V _{GS} = 0V		0.9	1.3	V	
Dynamic⁽¹⁾							
Total Gate Charge	Q _g	V _{DS} = 15V, V _{GS} = 5V, I _D = 50A		16	22	nC	
			V _{DS} = 15V, V _{GS} = 10V I _D = 50A		35		60
					8		
Gate-Source Charge	Q _{gs}						
Gate-Drain Charge	Q _{gd}			6			
Turn-On Delay Time	t _{d(on)}	V _{DD} = 15V, R _L = 15Ω I _D = 1A, V _{GEN} = 10V R _G = 6Ω		11	20	ns	
Rise Time	t _r			11	20		
Turn-Off Delay Time	t _{d(off)}			48	80		
Fall Time	t _f			15	30		
Input Capacitance	C _{iss}	V _{GS} = 0V	–	1850	–	pF	
Output Capacitance	C _{oss}	V _{DS} = 15V	–	315	–		
Reverse Transfer Capacitance	C _{rss}	f = 1.0MHz	–	145	–		
Source-Drain Reverse Recovery Time	t _{rr}	I _F = 25A, di/dt = 100A/μs		160		ns	

Note:

(1) Pulse test; pulse width ≤ 300 μs, duty cycle ≤ 2%

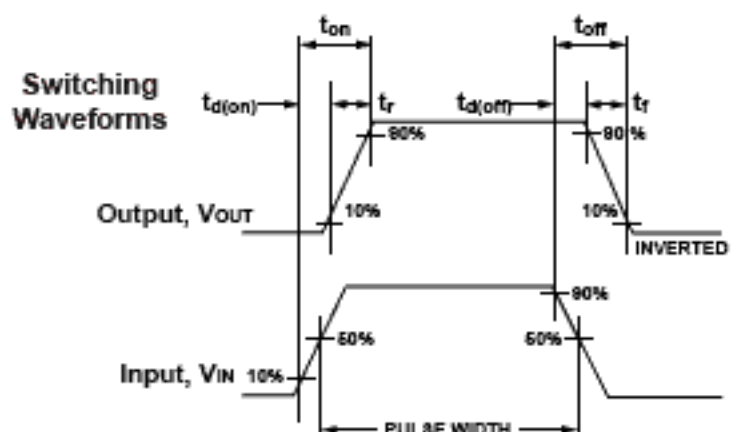
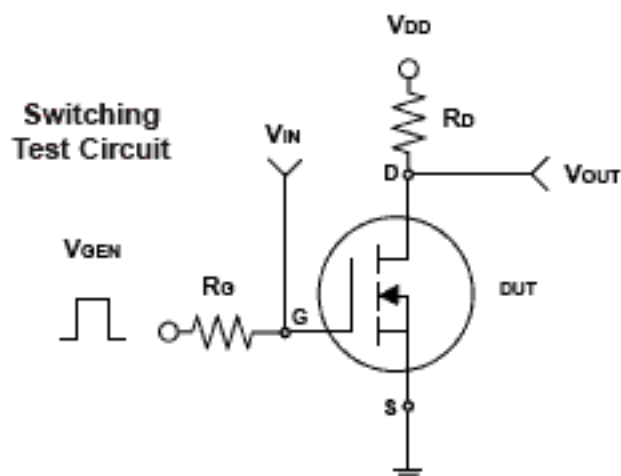

N-Channel Enhancement-Mode MOSFET

Ratings and Characteristic Curves (T_A = 25°C unless otherwise noted)

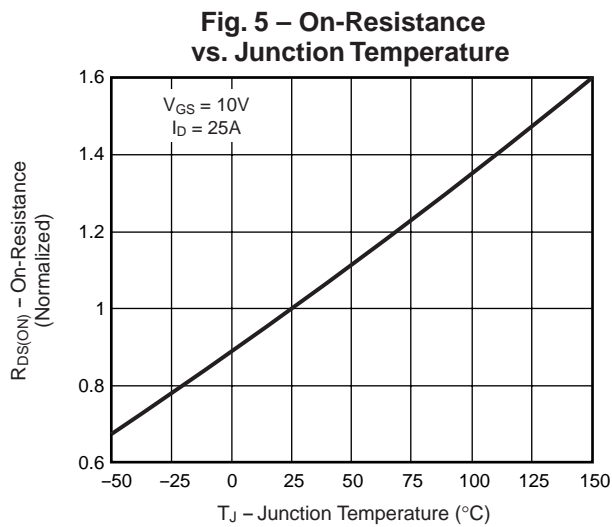
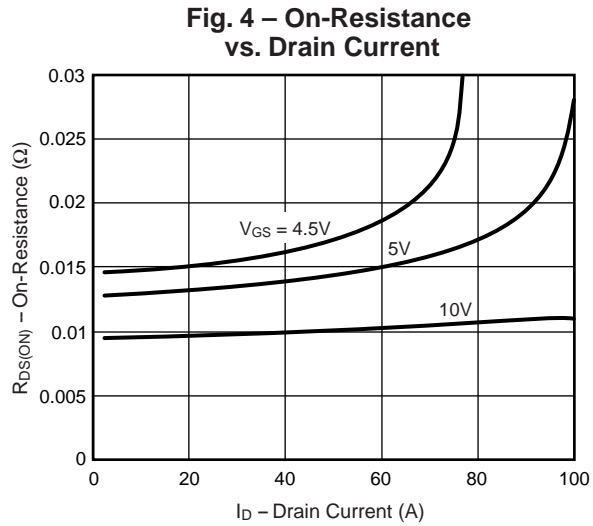
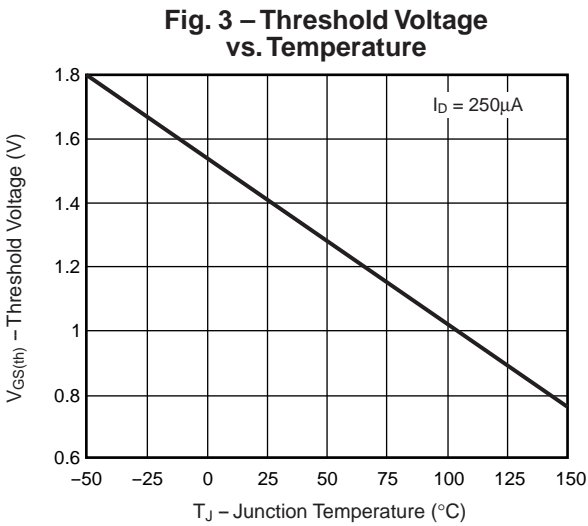
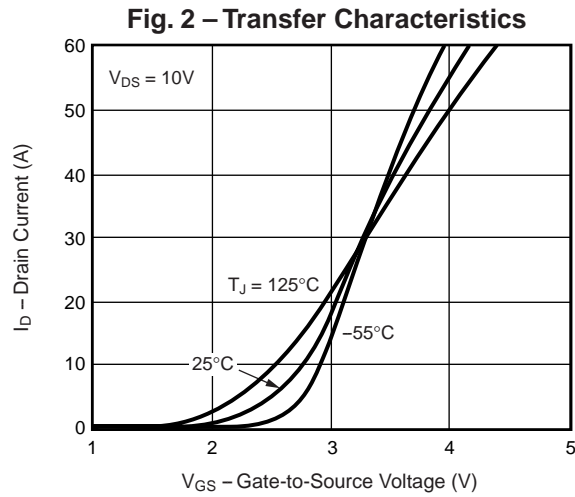
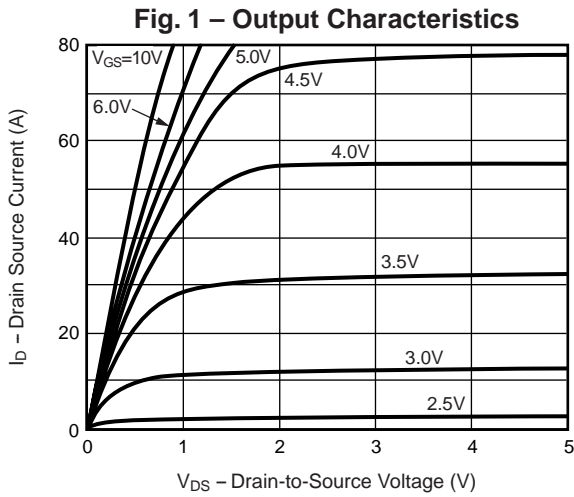

N-Channel Enhancement-Mode MOSFET

Ratings and Characteristic Curves (T_A = 25°C unless otherwise noted)

Fig. 6 – On-Resistance vs. Gate-to-Source Voltage

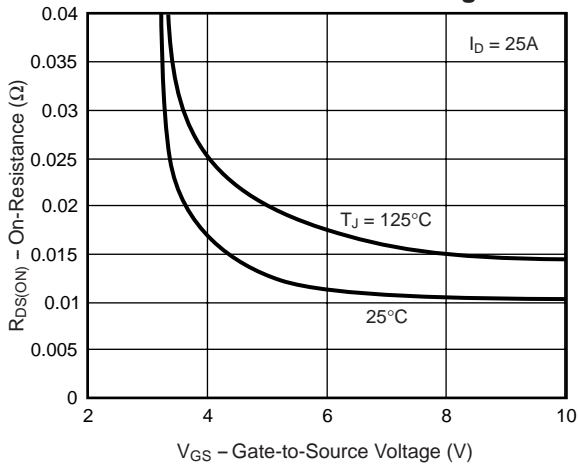

Fig. 7 – Gate Charge

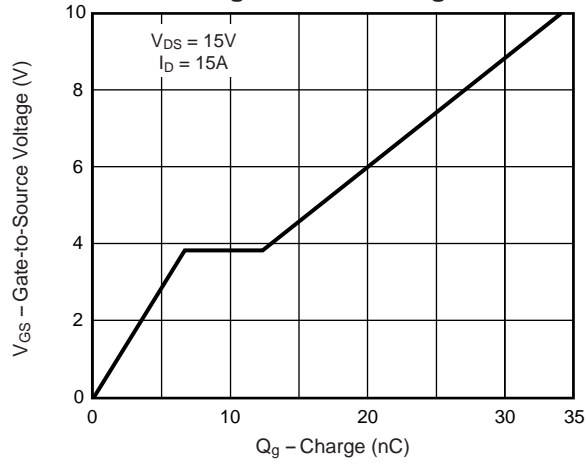

Fig. 8 – Capacitance

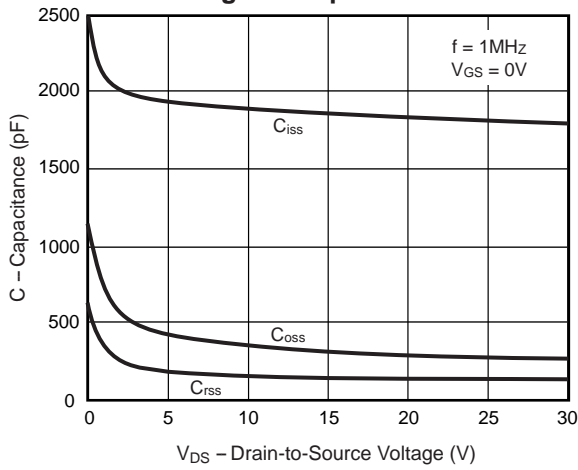
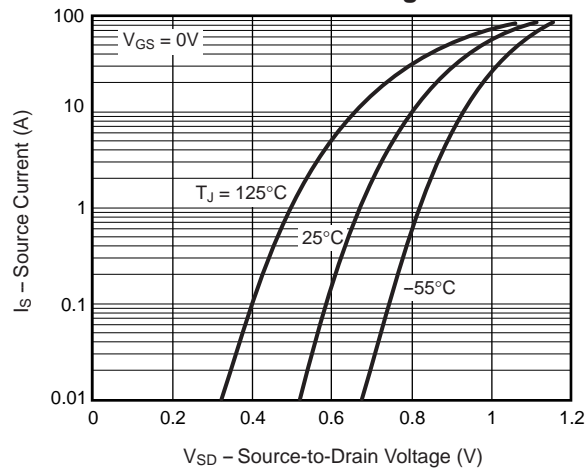

Fig. 9 – Source-Drain Diode Forward Voltage



N-Channel Enhancement-Mode MOSFET

Ratings and Characteristic Curves (T_A = 25°C unless otherwise noted)

Fig. 10 – Breakdown Voltage vs. Junction Temperature

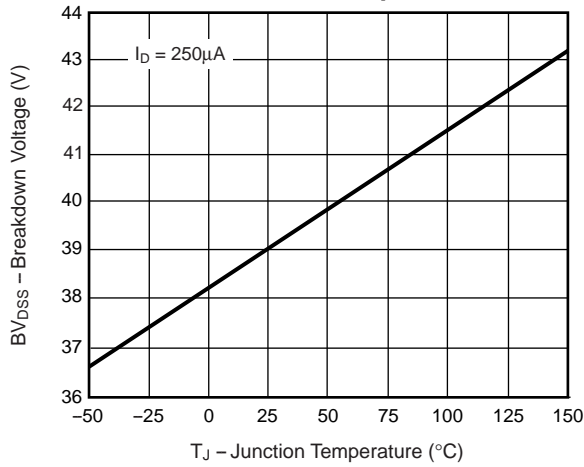

Fig. 11 – Transient Thermal Impedance

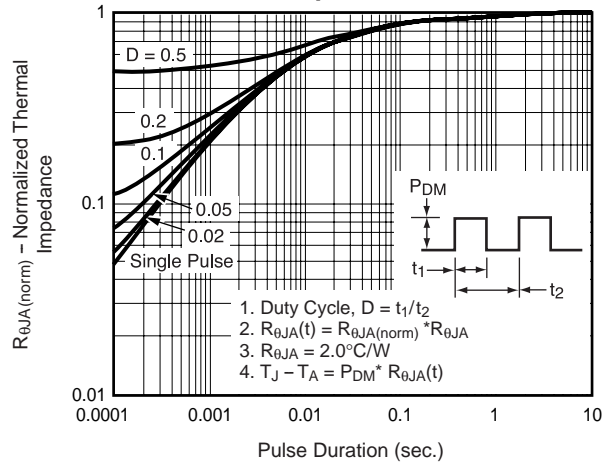

Fig. 12 – Power vs. Pulse Duration

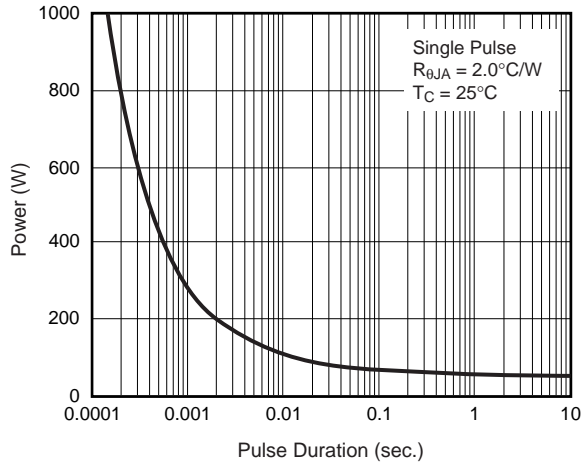

Fig. 13 – Maximum Safe Operating Area

