



# SEMICONDUCTOR TECHNICAL DATA

## FTK3857T/L N CHANNEL JUNCTION FIELD EFFECT TRANSISTOR

CONDENSER MICROPHONE APPLICATION.

### FEATURES

- Especially Suited for Use in Audio, Telephone.
- Capacitor Microphones.
- Excellent Voltage Characteristics.
- Excellent Transient Characteristics.

### MAXIMUM RATING (Ta=25°C)

CHARACTERISTIC	SYMBOL	RATING	UNIT
Gate-Drain Voltage	$V_{GDO}$	-20	V
Gate Current	$I_G$	10	mA
Drain Current	$I_D$	1	mA
Drain Power Dissipation	$P_D$	100	mW
Junction Temperature	$T_j$	150	°C
Storage Temperature Range	$T_{stg}$	-55 ~ 150	°C

### Marking

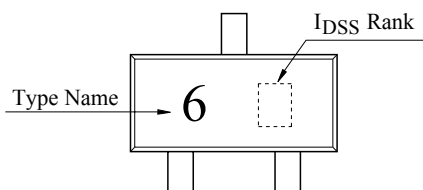

KTF3857T	SOT-923
KTF3857L	LLP-923

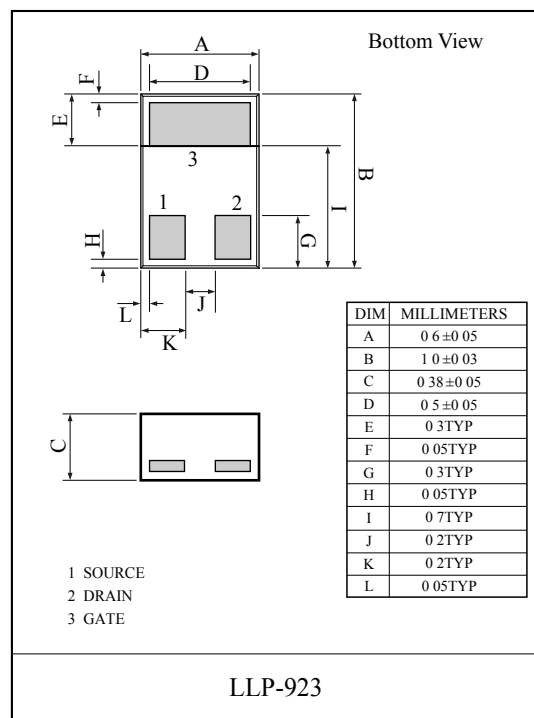
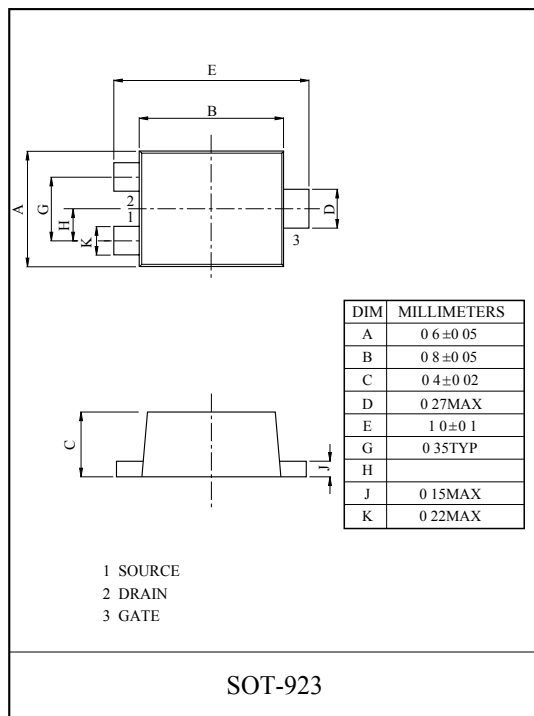

### ELECTRICAL CHARACTERISTICS (Ta=25°C)

CHARACTERISTIC	SYMBOL	TEST CONDITION	MIN.	TYP.	MAX.	UNIT
Gate-Drain Breakdown Voltage	$V_{(BR)GDO}$	$I_G = -100\mu A$	-20	-	-	V
Gate-Source Cut-off Voltage	$V_{GS(OFF)}$	$V_{DS} = 5V, I_D = 1\mu A$	-	-0.6	-1.5	V
Drain Current	$I_{DSS}$ (Note)	$V_{DS} = 5V, V_{GS} = 0$	150	-	320	$\mu A$
Forward Transfer Admittance	$ y_{fs} $	$V_{DS} = 5V, V_{GS} = 0, f = 1kHz$	0.4	1.2	-	mS
Input Capacitance	$C_{iss}$	$V_{DS} = 5V, V_{GS} = 0, f = 1MHz$	-	3.5	-	pF
Reverse Transfer Capacitance	$C_{rss}$	$V_{DS} = 5V, V_{GS} = 0, f = 1MHz$	-	0.65	-	pF

Note :  $I_{DSS}$  Classification B:150~240, C:210~320

## ELECTRICAL CHARACTERISTICS

( $T_a=25^\circ\text{C}$ ,  $V_{CC}=4.5\text{V}$ ,  $R_L=1\text{k}\Omega$ ,  $C_{in}=15\text{pF}$ , See Specified Test Circuit.)

CHARACTERISTIC	SYMBOL	TEST CONDITION	MIN.	TYP.	MAX.	UNIT
Voltage Gain	$G_V$	$V_{in}=10\text{mV}$ , $f=1\text{kHz}$	-	-3.0	-	dB
Reduced Voltage Characteristic	$\Delta G_{VV}$	$V_{in}=10\text{mV}$ , $f=1\text{kHz}$ $V_{CC}=4.5\text{V}\rightarrow 1.5\text{V}$	-	-1.2	-4.0	dB
Frequency Characteristic	$\Delta G_{VF}$	$f=1\text{kHz} \sim 110\text{Hz}$	-	-	-1.0	dB
Input Resistance	$Z_{in}$	$f=1\text{kHz}$	25	-	-	$\text{M}\Omega$
Output Resistance	$Z_O$	$f=1\text{kHz}$	-	-	700	$\Omega$
Total Harmonic Distortion	THD	$V_{in}=30\text{mV}$ , $f=1\text{kHz}$	-	1.0	-	%
Output Noise Voltage	$V_{NO}$	$V_{in}=0$ , A curve	-	-	-110	dB

## SPECIFIED TEST CIRCUIT

- Voltage gain.
- Frequency Characteristic.
- Distortion.
- Reduced Voltage Characteristic.

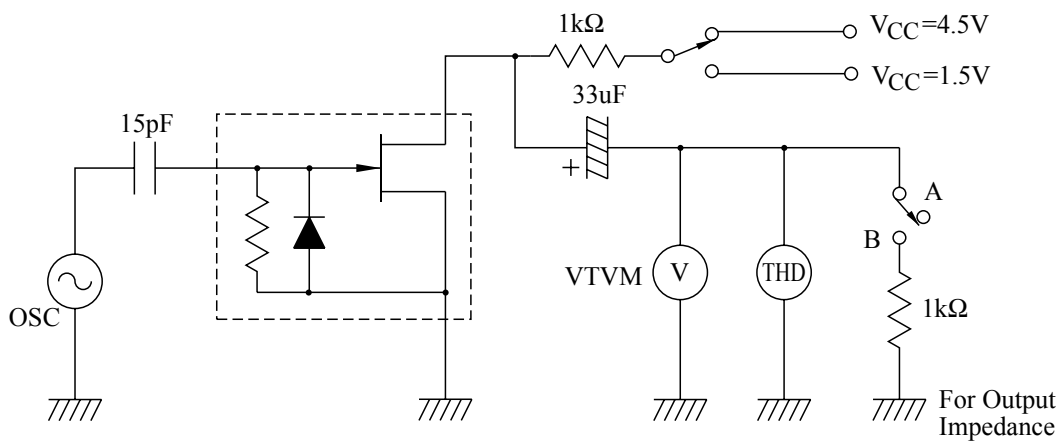

$I_D - V_{DS}$

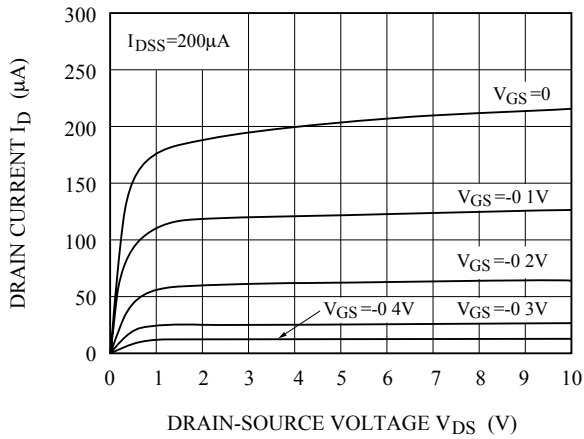

$I_D - V_{GS}$

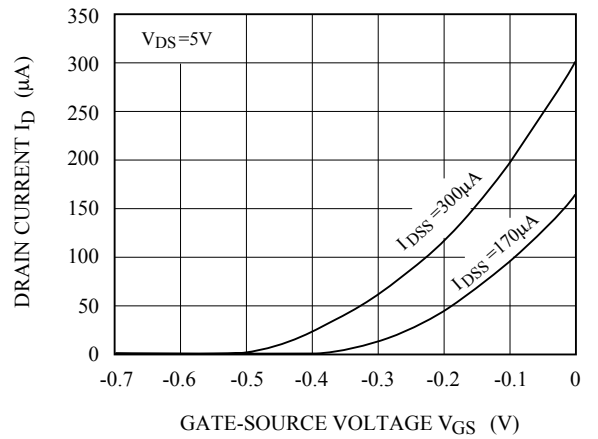

$|y_{fs}| - I_{DSS}$

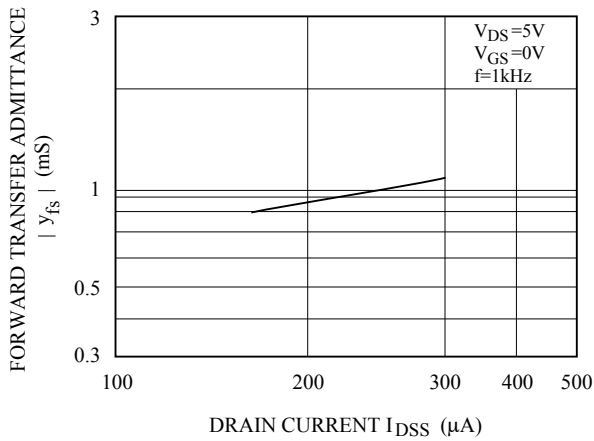

$V_{GS(off)} - I_{DSS}$

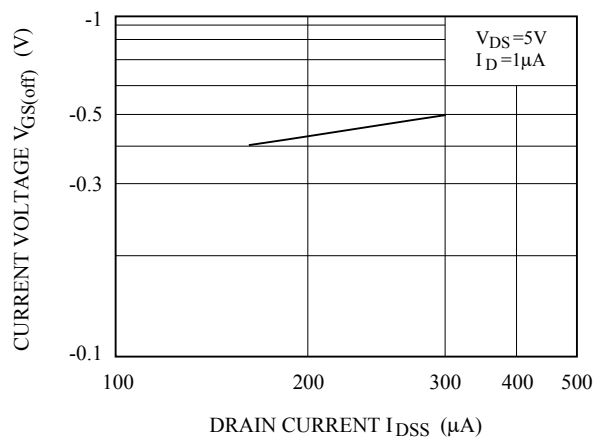

$C_{iss} - V_{DS}$

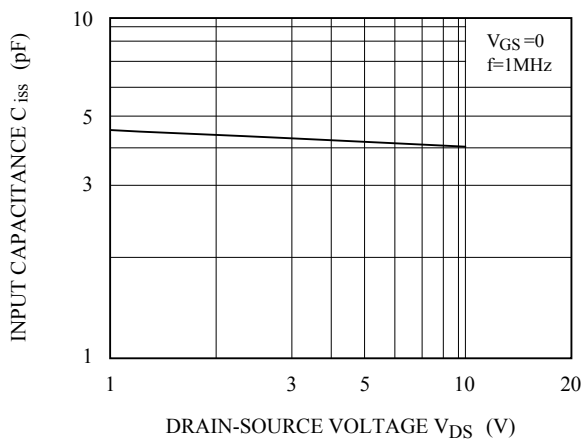

$C_{rss} - V_{DS}$

