

**Major Ratings and Characteristics**

Characteristics	Limits	Units
$I_{F(AV)}$	30	A
$V_{RRM}$ (Per Leg)	60	V
$I_{FSM}$ @ $t_p = 8.3ms$ half-sine (Per Leg)	120	A
$V_F$ @ 30Apk, $T_J = 125^\circ C$ (Per Leg)	1.01	V
$T_J, T_{stg}$ Operating and storage	-55 to 150	$^\circ C$

**Description / Features**

The 30SCLJQ060 center tap Schottky rectifier has been expressly designed to meet the rigorous requirements of HiRel environments. It is packaged in the hermetic surface mount SMD-0.5 ceramic package. The device's forward voltage drop and reverse leakage current are optimized for the lowest power loss and the highest circuit efficiency for typical high frequency switching power supplies and resonant power converters. Full MIL-PRF-19500 quality conformance testing is available on source control drawings to TX, TXV and S quality levels.

- Hermetically Sealed
- Center Tap
- Low Forward Voltage Drop
- High Frequency Operation
- Guard Ring for Enhanced Ruggedness and Long term Reliability
- Surface Mount
- Lightweight
- ESD Rating: Class NS per MIL-STD-750, Method 1020

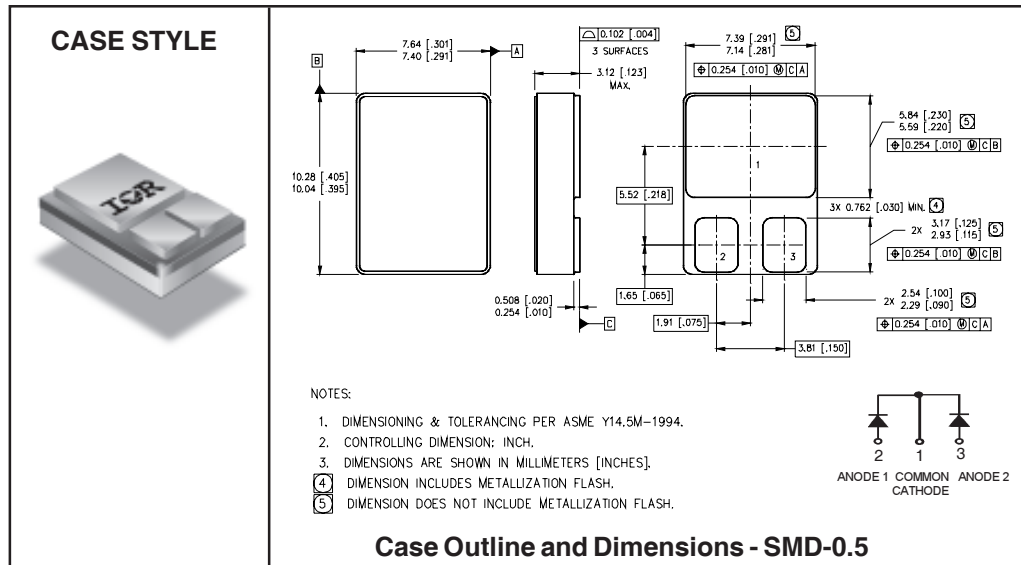

**Voltage Ratings**

Part number	30SCLJQ060
V <sub>R</sub> Max. DC Reverse Voltage (V) (Per Leg)	60
V <sub>RWM</sub> Max. Working Peak Reverse Voltage (V) (Per Leg)	

**Absolute Maximum Ratings**

Parameters	Limits	Units	Conditions
I <sub>F(AV)</sub> Max. Average Forward Current See Fig. 5	30	A	50% duty cycle @ T <sub>C</sub> = 77°C, square waveform
I <sub>FSM</sub> Max. Peak One Cycle Non - Repetitive Surge Current (Per Leg)	120	A	@ t <sub>p</sub> = 8.3 ms half-sine

**Electrical Specifications**

Parameters	Limits	Units	Conditions
V <sub>FM</sub> Max. Forward Voltage Drop (Per Leg) See Fig. 1 ①	0.86	V	@ 15A T <sub>J</sub> = -55°C
	1.22	V	@ 30A
	0.90	V	@ 15A T <sub>J</sub> = 25°C
	1.24	V	@ 30A
	0.78	V	@ 15A T <sub>J</sub> = 125°C
	1.01	V	@ 30A
I <sub>RM</sub> Max. Reverse Leakage Current (Per Leg) See Fig. 2 ①	0.045	mA	T <sub>J</sub> = 25°C V <sub>R</sub> = rated V <sub>R</sub>
	50	mA	T <sub>J</sub> = 125°C
C <sub>T</sub> Max. Junction Capacitance (Per Leg)	600	pF	V <sub>R</sub> = 5V <sub>DC</sub> (1MHz, 25°C)
L <sub>S</sub> Typical Series Inductance (Per Leg)	4.8	nH	Measured from center of cathode pad to center of anode pad

**Thermal-Mechanical Specifications**

Parameters	Limits	Units	Conditions
T <sub>J</sub> Max. Junction Temperature Range	-55 to 150	°C	
T <sub>stg</sub> Max. Storage Temperature Range	-55 to 150	°C	
R <sub>thJC</sub> Max. Thermal Resistance, Junction to Case (Per Leg)	3.5	°C/W	DC operation See Fig. 4
R <sub>thJC</sub> Max. Thermal Resistance, Junction to Case (Per Package)	1.75	°C/W	DC operation
wt Weight (Typical)	1.0	g	
Die Size (Typical)	70X92	mils	
Case Style	SMD-0.5		

① Pulse Width &lt; 300µs, Duty Cycle &lt; 2%

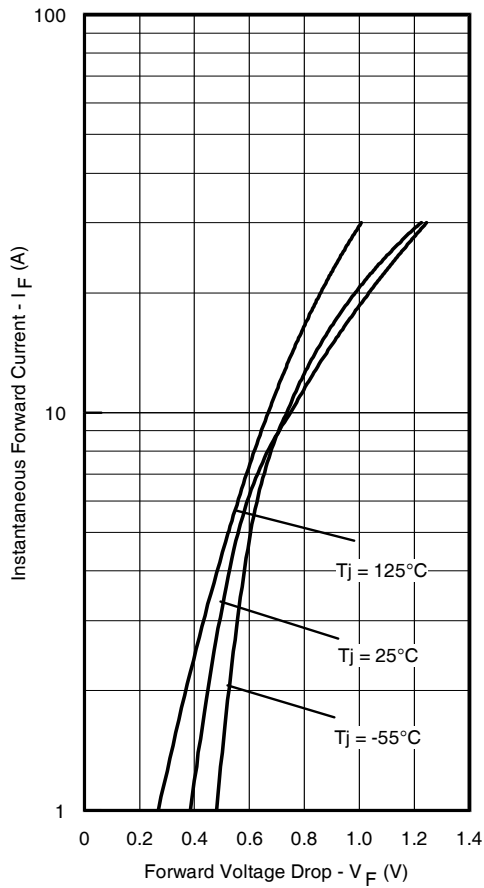

Fig. 1 - Max. Forward Voltage Drop Characteristics (Per Leg)

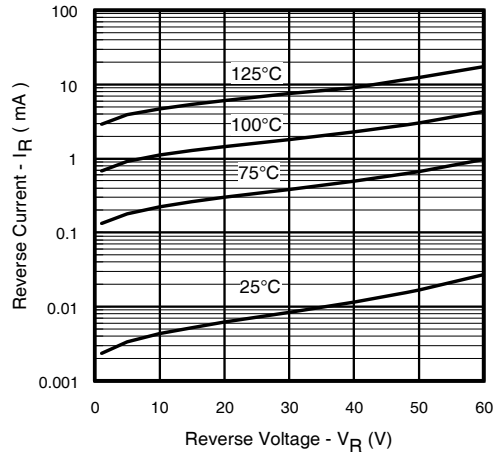

Fig. 2 - Typical Values of Reverse Current Vs. Reverse Voltage (Per Leg)

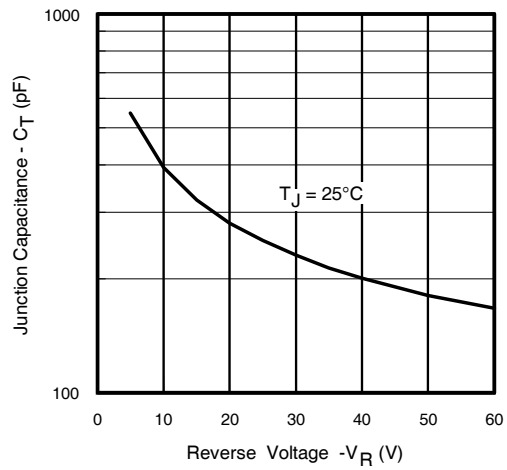

Fig. 3 - Typical Junction Capacitance Vs. Reverse Voltage (Per Leg)

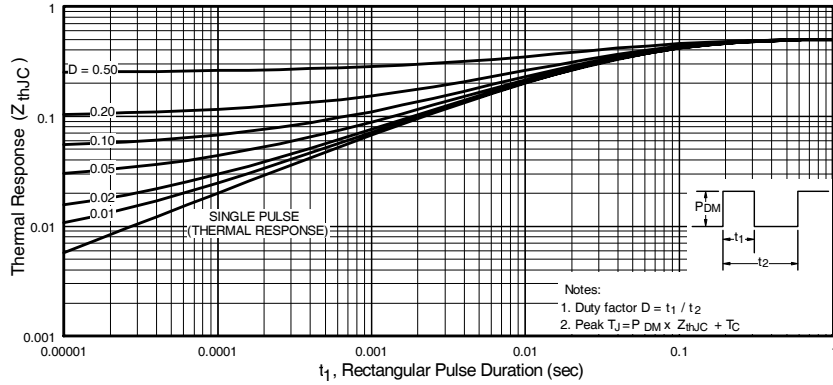

Fig. 4 - Max. Thermal Impedance  $Z_{thJC}$  Characteristics (Per Leg)

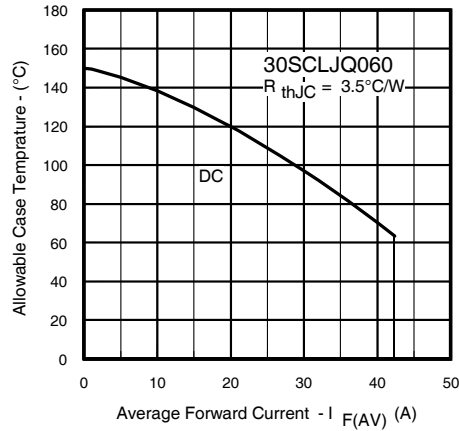

Fig. 5 - Max. Allowable Case Temperature Vs. Average Forward Current (Per Leg)