

BR3500W - BR3510W SILICON BRIDGE RECTIFIERS

PRV : 50 - 1000 Volts
Io : 35 Amperes

FEATURES :

- * High current capability
- * High surge current capability
- * High reliability
- * Low reverse current
- * Low forward voltage drop
- * High case dielectric strength
- * Pb / RoHS Free

MECHANICAL DATA :

- * Case : Molded plastic with heatsink integrally mounted in the bridge encapsulation
- * Epoxy : UL94V-O rate flame retardant
- * Terminals : Plated lead solderable per MIL-STD-202, Method 208 guaranteed
- * Polarity : Polarity symbols marked on case
- * Mounting position : Bolt down on heat-sink with silicone thermal compound between bridge and mounting surface for maximum heat transfer efficiency
- * Weight : 15.95 grams

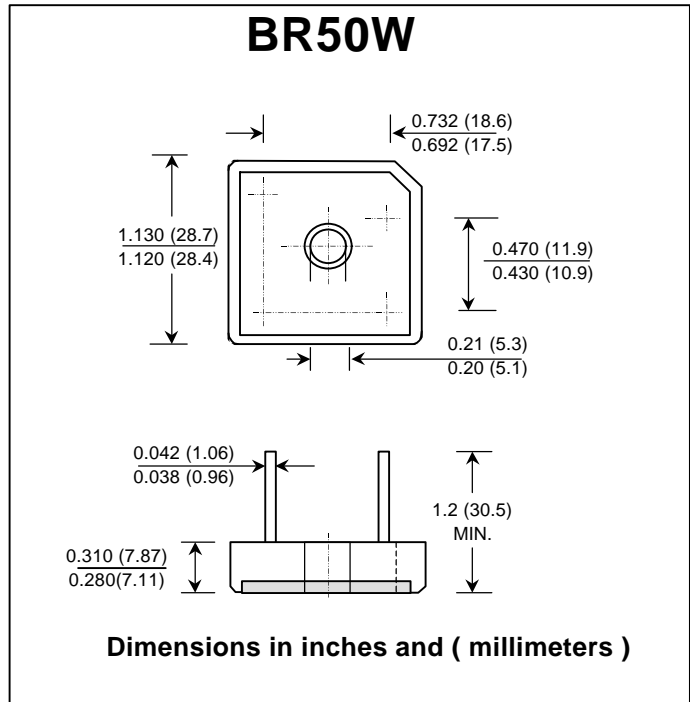

MAXIMUM RATINGS AND ELECTRICAL CHARACTERISTICS

Rating at 25 °C ambient temperature unless otherwise specified.
Single phase, half wave, 60 Hz, resistive or inductive load.
For capacitive load, derate current by 20%.

RATING	SYMBOL	BR 3500W	BR 3501W	BR 3502W	BR 3504W	BR 3506W	BR 3508W	BR 3510W	UNITS
Maximum Recurrent Peak Reverse Voltage	V _{RRM}	50	100	200	400	600	800	1000	V
Maximum RMS Voltage	V _{RMS}	35	70	140	280	420	560	700	V
Maximum DC Blocking Voltage	V _{DC}	50	100	200	400	600	800	1000	V
Maximum Average Forward Current T _c = 55°C	I _{F(AV)}	35							A
Peak Forward Surge Current Single half sine wave Superimposed on rated load (JEDEC Method)	I _{FSM}	400							A
Current Squared Time at t < 8.3 ms.	I ² t	660							A ² S
Maximum Forward Voltage per Diode at I _F = 17.5 A	V _F	1.1							V
Maximum DC Reverse Current Ta = 25 °C at Rated DC Blocking Voltage Ta = 100 °C	I _R	10							µA
	I _{R(H)}	200							mA
Typical Thermal Resistance at Junction to Case (Note 1)	R _{θJC}	1.5							°C/W
Typical Thermal Resistance at Junction to Ambient	R _{θJA}	10							°C/W
Operating Junction Temperature Range	T _J	- 40 to + 150							°C
Storage Temperature Range	T _{STG}	- 40 to + 150							°C

Notes :

1. Thermal Resistance from junction to case with units mounted on a 7.5" x 3.5" x 4.6" (19cm.x 9cm.x 11.8cm.) Al.-Finned Plate

RATING AND CHARACTERISTIC CURVES (BR3500W THRU BR3510W)

FIG.1 - DERATING CURVE FOR OUTPUT RECTIFIED CURRENT

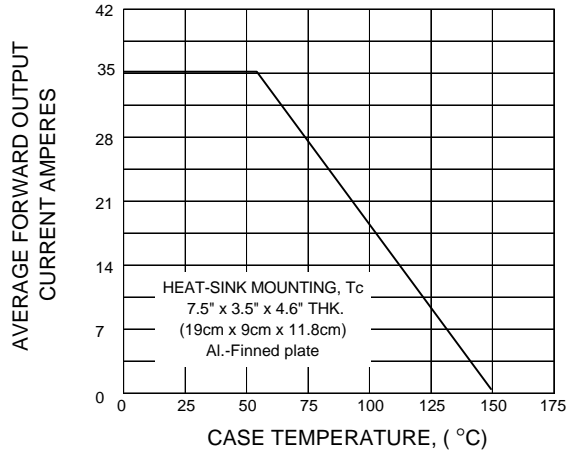

FIG.2 - MAXIMUM NON-REPETITIVE PEAK FORWARD SURGE CURRENT

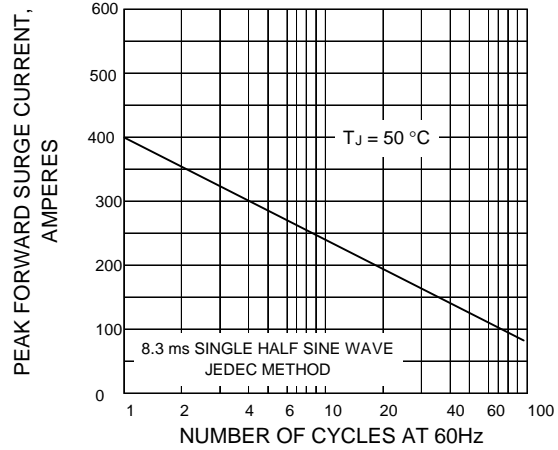

FIG.3 - TYPICAL FORWARD CHARACTERISTICS PER DIODE

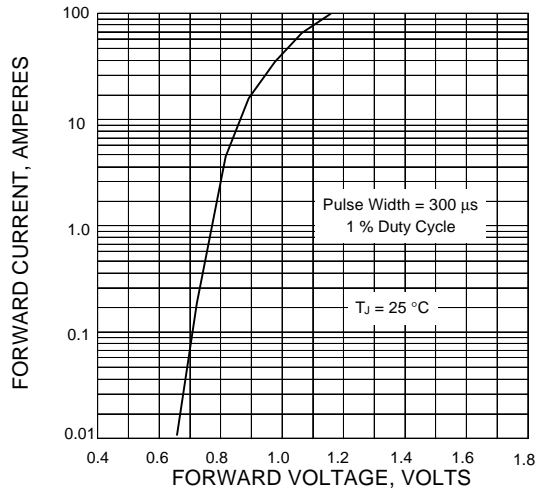

FIG.4 - TYPICAL REVERSE CHARACTERISTICS PER DIODE

