

# BR602L

**PRV : 200 Volts**

**Io : 6.0 Amperes**

## FEATURES :

- \* High current capability
- \* High surge current capability
- \* High reliability
- \* Low reverse current
- \* Low forward voltage drop
- \* Ideal for printed circuit board
- \* **Pb / RoHS Free**

## MECHANICAL DATA :

- \* Case : Reliable low cost construction utilizing molded plastic technique
- \* Epoxy : UL94V-O rate flame retardant
- \* Lead : Axial lead solderable per MIL - STD 202 , Method 208 guaranteed
- \* Polarity : Polarity symbols marked on case
- \* Mounting position : Any
- \* Weight : 3.16 grams

# SILICON BRIDGE RECTIFIER

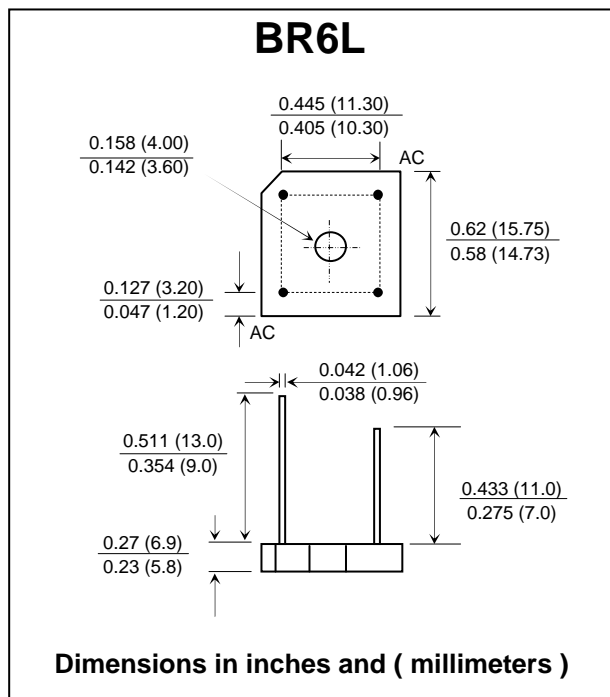

## MAXIMUM RATINGS AND ELECTRICAL CHARACTERISTICS

Rating at 25 °C ambient temperature unless otherwise specific.  
Single phase, half wave, 60 Hz, resistive or inductive load  
For capacitive load, derate current by 20%

RATING	SYMBOL	VALUE	UNIT
Maximum Recurrent Peak Reverse Voltage	V <sub>RRM</sub>	200	V
Maximum RMS Voltage	V <sub>RMS</sub>	140	V
Maximum DC Blocking Voltage	V <sub>DC</sub>	200	V
Maximum Average Forward Current T <sub>c</sub> =50°C	I <sub>F(AV)</sub>	6.0	A
Peak Forward Surge Current, Single half sine wave Superimposed on rated load (JEDEC Method)	I <sub>FSM</sub>	200	A
Current Squared Time at t < 8.3 ms.	I <sup>2</sup> t	64	A <sup>2</sup> S
Maximum Forward Voltage per Diode at I <sub>F</sub> =3 A.	V <sub>F</sub>	1.0	V
Maximum DC Reverse Current Ta = 25 °C at Rated DC Blocking Voltage Ta = 100 °C	I <sub>R</sub>	10	μA
	I <sub>R(H)</sub>	200	μA
Typical Thermal Resistance (Note 1)	RθJC	8.0	°C/W
Operating Junction Temperature Range	T <sub>J</sub>	- 40 to + 150	°C
Storage Temperature Range	T <sub>STG</sub>	- 40 to + 150	°C

### Notes :

1. Thermal Resistance from junction to case with units mounted on a 2.6" x 1.4" x 0.06" THK (6.5cm.x 3.5cm.x 0.15cm.) Al. Plate. Heatsink.

**RATING AND CHARACTERISTIC CURVES ( BR602L )**

**FIG.1 - DERATING CURVE FOR OUTPUT RECTIFIED CURRENT**

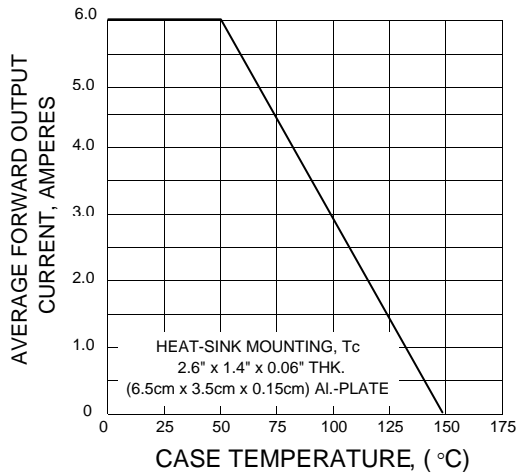

**FIG.2 - MAXIMUM NON-REPETITIVE PEAK FORWARD SURGE CURRENT**

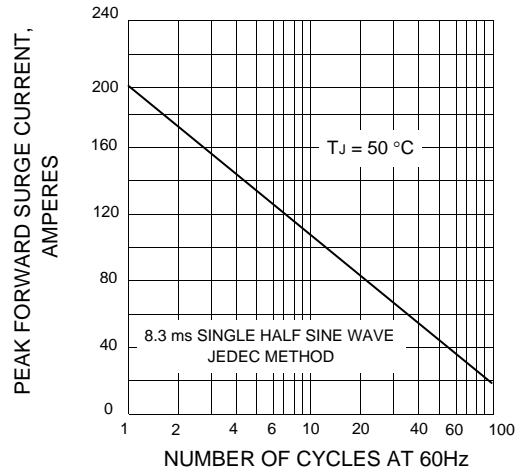

**FIG.3 - TYPICAL FORWARD CHARACTERISTICS PER DIODE**

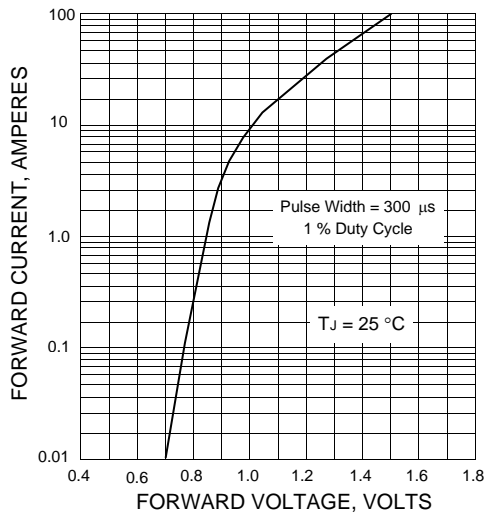

**FIG.4 - TYPICAL REVERSE CHARACTERISTICS PER DIODE**

