

Fast Recovery Diodes

FEATURES

- High surge capability
- Qualified for industrial level
- International standard case DO-205AB
- Both metric and inch threads

TYPICAL APPLICATIONS

- Power supplies
- Machine tools control
- High power drives
- Welders
- Medium traction

MAJOR RATINGS AND CHARACTERISTICS			
PARAMETER	TEST CONDITIONS	VALUES	UNITS
$I_{F(AV)}$		240	A
	T_{Case}	100	°C
$I_{F(RMS)}$		380	A
	T_{Case}	100	°C
I_{FSM}	50 Hz	6560	A
	60 Hz	7150	A
I^2t	50 Hz	195	kA ² s
	60 Hz	213	kA ² s
V_{DRM}/V_{RRM}		200 to 1600	V
T_J		-40 to 150	°C

ELECTRICAL SPECIFICATIONS

VOLTAGE RATINGS				
SERIES	VOLTAGE CODE	V_{DRM}/V_{RRM} , MAX. RE- PETITIVE PEAK AND OFF-STATE VOLTAGE (V)	V_{RSM} , MAX. NON- REPETITIVE PEAK VOLTAGE (V)	I_{DRM}/I_{RRM} , MAX. at T_J = $T_{J(Max.)}$ (mA)
DF240/...10	02	200	300	100
DF240/...10	04	400	500	
DF240/...10	06	600	700	
DF240/...10	08	800	900	
DF240/...10	10	1000	1100	
DF240/...10	12	1200	1300	
DF240/...10	14	1400	1500	
DF240/...10	16	1600	1700	

Fast Recovery Diodes

MAXIMUM ALLOWABLE RATINGS					
SYMBOL	DESCRIPTION	TEST CONDITIONS		VALUE	UNITS
$I_{F(AV)}$	Maximum average on-state current at heatsink temperature	180° conduction, half sine wave		240	A
				100	°C
$I_{F(RMS)}$	Maximum RMS on-state current	DC at 25°C heatsink temperature		380	A
I_{FSM}	Maximum peak, one-cycle non-repetitive surge current	t = 10 ms	100% V_{RRM} reapplied	Sinusoidal half wave, initial $T_J = T_J \text{ max.}$	kA
		t = 8.3 ms			
		t = 10 ms	No voltage reapplied		
		t = 8.3 ms			
I^2t	Maximum I^2t	t = 10 ms	100% V_{RRM} reapplied		kA ² s
		t = 8.3 ms			
		t = 10 ms	No voltage reapplied		
		t = 8.3 ms			
$I^2t^{1/2}$	Maximum $I^2t^{1/2}$	t = 0.1 to 10 ms, no voltage reapplied		2340	kA ² s ^{1/2}
$I_{RM(REC)}$	Peak reverse recovery current	-		50	A
I_{RM}	Peak reverse current	-		100	mA
I_{FM}	Peak forward current	-		240	A
di/dt	Max.non-rep. rate of rise of current	$T_J = 25^\circ\text{C}, V_D = V_{DRM}, I_{FM} = 1\text{A}$		50	A/ μs
t_{rr}	Max.reverse recovery time	$T_J = 25^\circ\text{C}, I_{FM} = 1\text{A}, V_R = 30\text{V}, -di_F/dt = 25\text{A}/\mu\text{s}$		1000	ns
		$T_J = 25^\circ\text{C}, -di_F/dt = 25\text{A}/\mu\text{s}, I_{FM} = \pi \times \text{rated } I_{F(AV)}$		2000	ns
$V_{F(TO)}$	Low level threshold voltage	$(16.7\% \times \pi \times I_{F(AV)} < I < \pi \times I_{F(AV)}), T_J = T_J \text{ max.}$		0.80	V
r_F	Low level on-state slope resistance			1.15	m Ω
V_{FM}	Maximum on-state voltage	$I_{pk} = 754\text{A}, 50\text{Hz half sine pulse}, T_J = T_J \text{ max.}$		1.75	V

THERMAL AND MECHANICAL SPECIFICATIONS				
SYMBOL	DESCRIPTION	TEST CONDITIONS	VALUE	UNITS
T_J	Maximum operating junction temperature	-	-40 to 150	°C
T_{Stg}	Maximum storage temperature	-	-40 to 150	
R_{thJ-hs}	Maximum thermal resistance, junction to heatsink	DC	0.20	°C/W
		180° sine wave	0.22	
		120° rectangular wave	0.24	
R_{thC-hs}	Maximum thermal resistance, case to heat-sink	Mtg. Surface smooth, flat, greased	0.03	
-	Mounting force, $\pm 10\%$	-	30	N.m
-	Approximate weight	-	250	g
-	Case style	-	DO-205AB	JEDEC

Fast Recovery Diodes

CURRENT FORM FACTOR								
FORM FACTOR	CONDUCTION ANGLE	15°	30°	45°	60°	90°	120°	180°
Sine wave		31.956	15.832	10.452	7.721	4.933	3.527	2.468
Rectangular wave		24.000	12.000	8.000	6.000	4.000	3.000	2.000

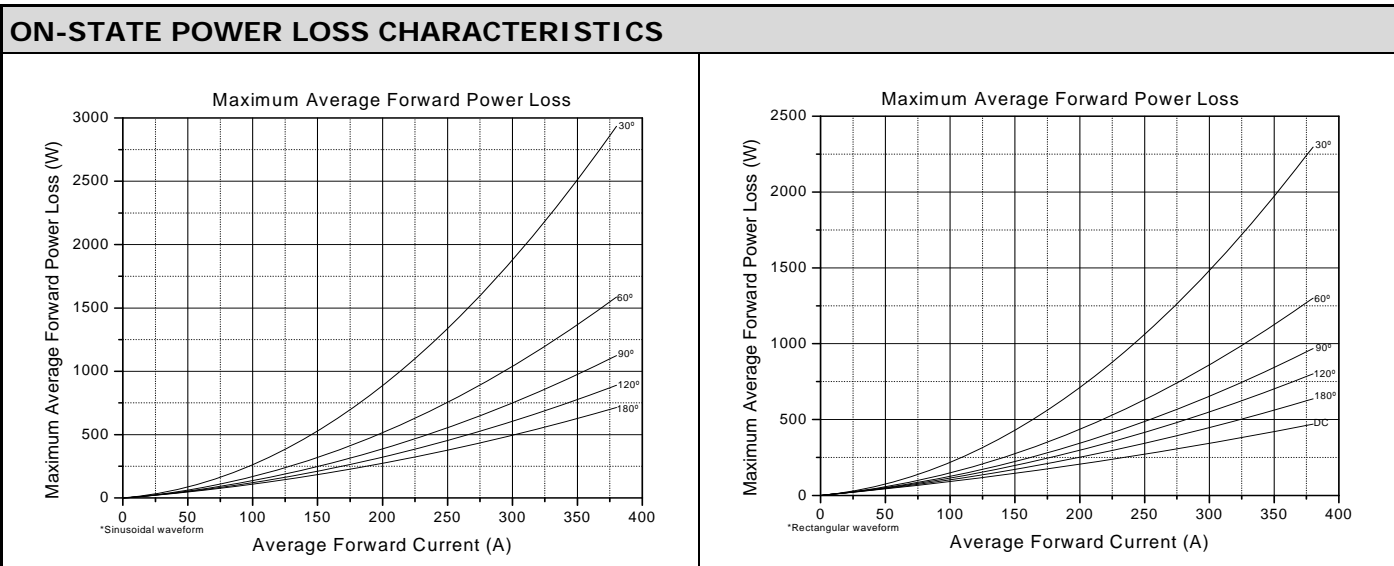
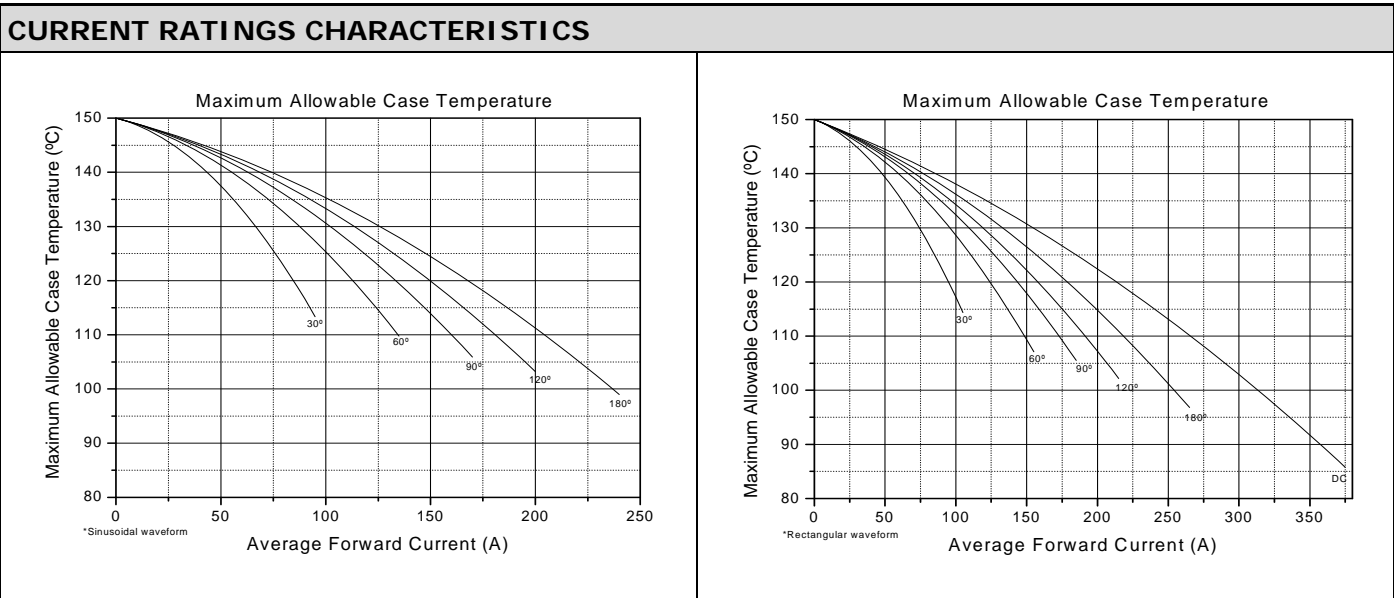

Fast Recovery Diodes

FORWARD VOLTAGE DROP / THERMAL IMPEDANCE CHARACTERISTICS

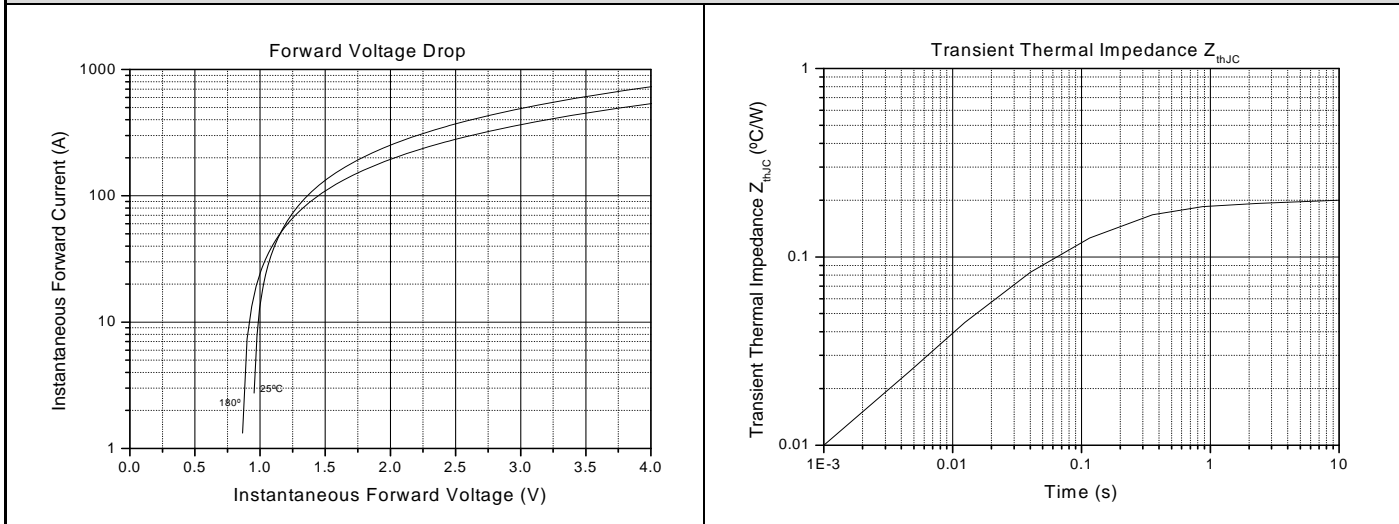

FREQUENCY CHARACTERISTICS

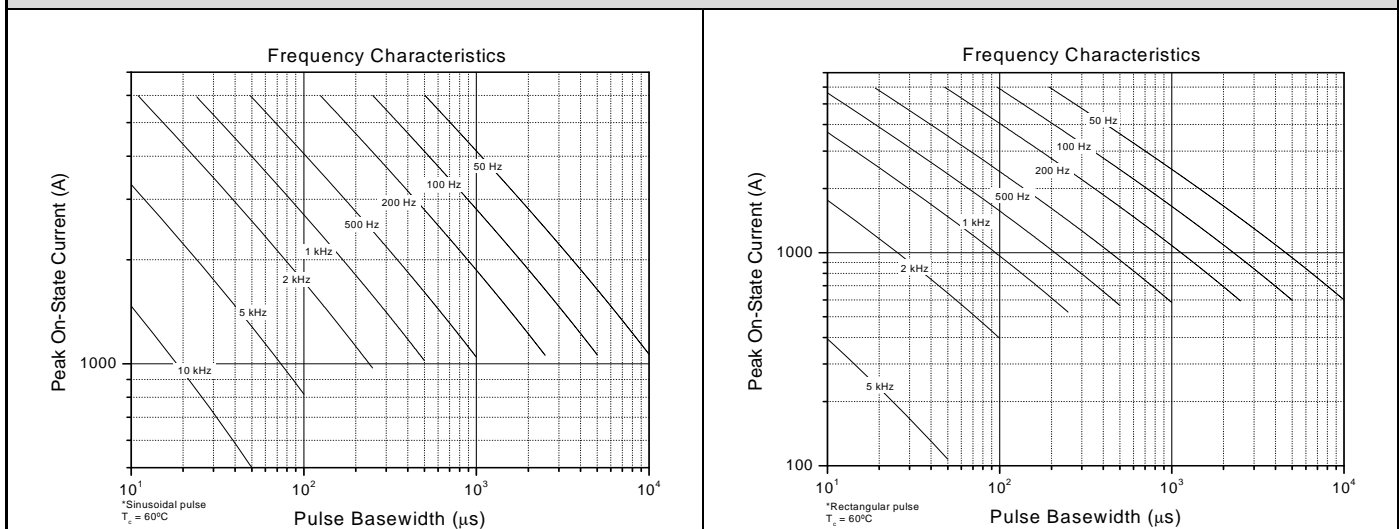

Fast Recovery Diodes

FREQUENCY CHARACTERISTICS

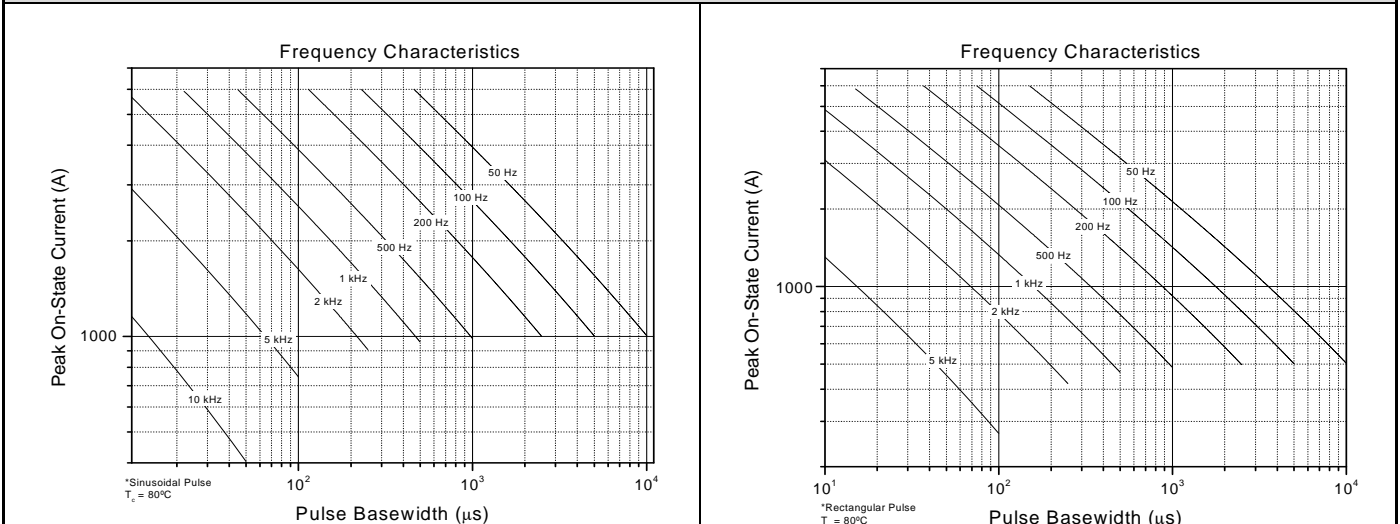

FREQUENCY CHARACTERISTICS

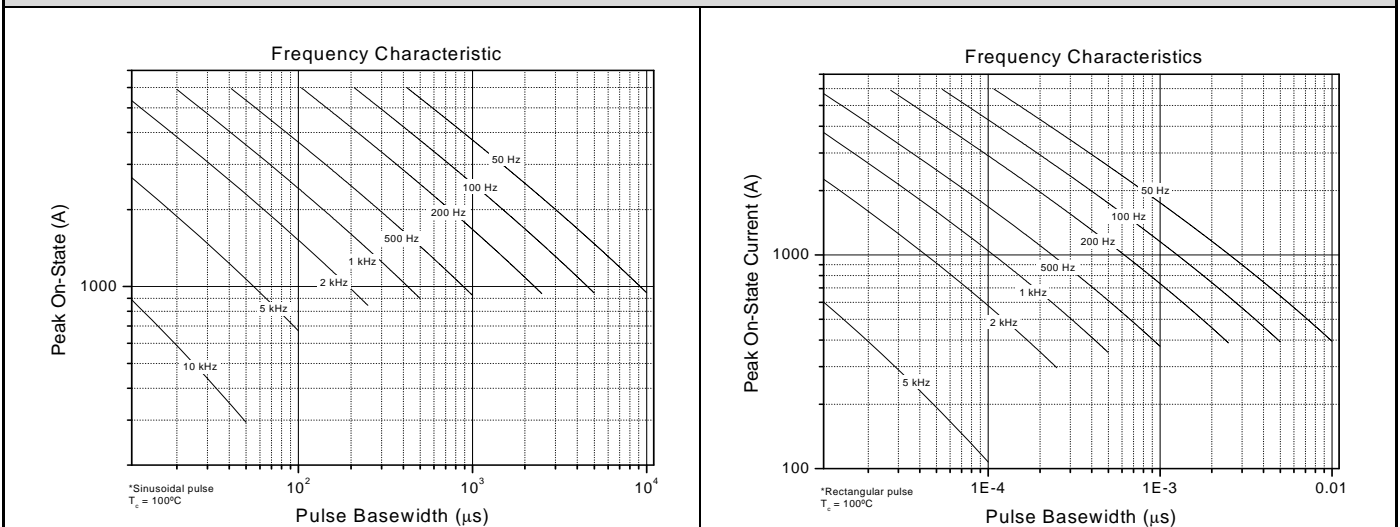

Fast Recovery Diodes

MAXIMUM ON-STATE POWER LOSS CHARACTERISTICS

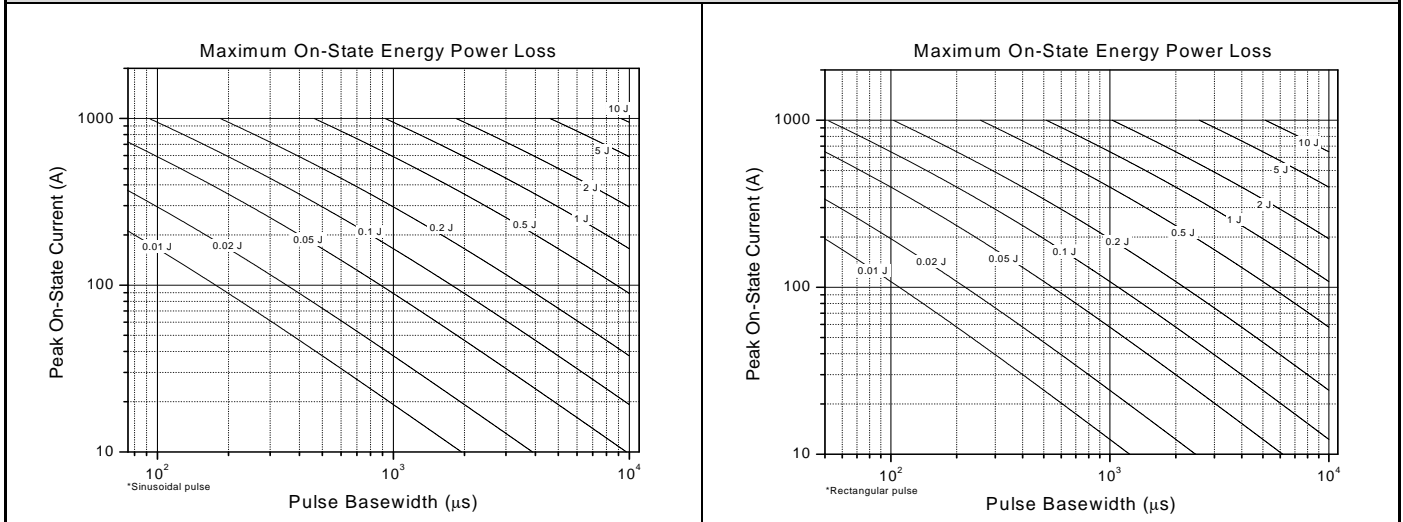

OUTLINE CHARACTERISTICS

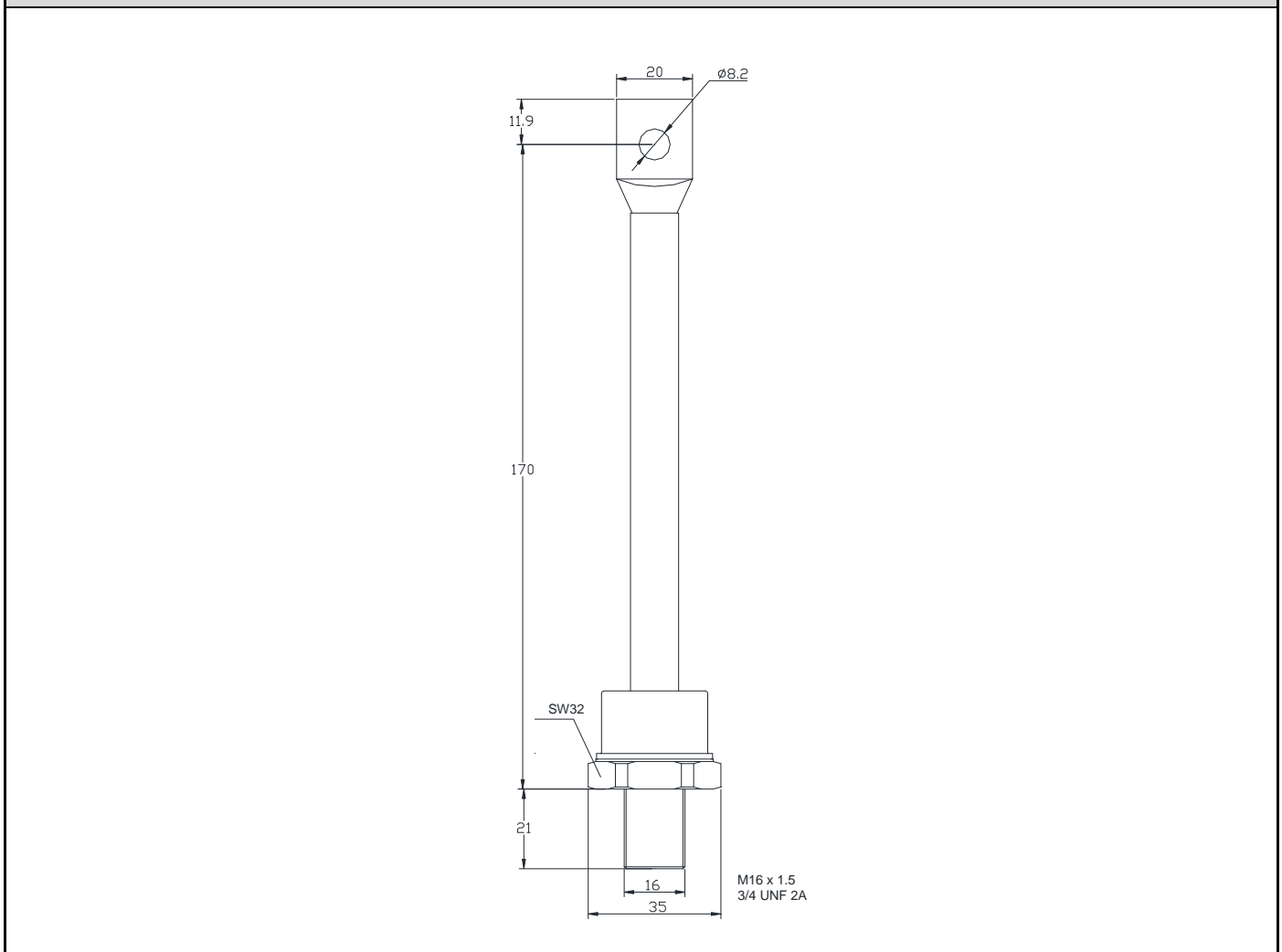

Fast Recovery Diodes

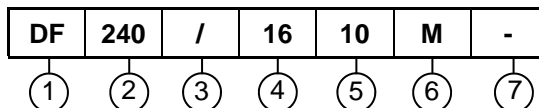
ORDERING INFORMATION
Device code

- | | |
|---|--|
| 1 | <ul style="list-style-type: none"> - N = Phase Control Thyristors - F = Fast Thyristors (inverter grade) - D = Normal Recovery Diodes - DF = Fast Recovery Diodes - DD = Module (diode-diode) - DT = Module (diode-thyristor) - TD = Module (thyristor-diode) - TT = Module (thyristor-thyristor) - P = Press-fit diode |
| 2 | <ul style="list-style-type: none"> - Average Current Code |
| 3 | <ul style="list-style-type: none"> - Essential Part Number |
| 4 | <ul style="list-style-type: none"> - Voltage Code x 100 = V_{RRM} |
| 5 | <ul style="list-style-type: none"> - Turn-off time (fast thyristors only) - Reverse Recovery Time (fast diodes only) |
| 6 | <ul style="list-style-type: none"> - M = Metric Thread - I = Inch Thread |
| 7 | <ul style="list-style-type: none"> - None = Anode to stud (stud diodes only) - R = Cathode to stud (stud diodes only) |

Disclaimer

All product specifications and data are subject to change without notice.

Komkraft Ind.Com.de Componentes Eletrônicos Ltda., its affiliates, agents and employees, and all persons acting on its or their behalf (collectively, "Komkraft"), disclaim any and all liability for any errors, inaccuracies or incompleteness contained herein or in any other disclosure relating to any product.

Komkraft disclaims any and all liability arising of the use or application of any product described herein or of any information provided herein to the maximum extent permitted by law. The product specifications do not expand or otherwise modify Komkraft's terms and conditions of purchase, including but not limited to the warranty expressed therein, which apply to these products.

The products shown herein are not designed for use in medical, life-saving or life-sustaining applications unless otherwise expressly indicated.