

Standard Recovery Diodes

FEATURES

- High surge capability
- Qualified for industrial level
- International standard case TO-200AD
- Ceramic insulator

TYPICAL APPLICATIONS

- Power supplies
- Machine tools control
- High power drives
- Welders
- Traction power supplies

MAJOR RATINGS AND CHARACTERISTICS			
PARAMETER	TEST CONDITIONS	VALUES	UNITS
$I_{F(AV)}$		2300	A
	T_{Case}	125	°C
$I_{F(RMS)}$		4420	A
	T_{Case}	125	°C
I_{FSM}	50 Hz	34100	A
	60 Hz	35700	A
I^2t	50 Hz	4907	kA ² s
	60 Hz	5300	kA ² s
V_{DRM}/V_{RRM}		200 to 1600	V
T_J		-40 to 180	°C

ELECTRICAL SPECIFICATIONS

VOLTAGE RATINGS				
SERIES	VOLTAGE CODE	V_{DRM}/V_{RRM} , MAX. RE- PETITIVE PEAK AND OFF-STATE VOLTAGE (V)	V_{RSM} , MAX. NON- REPETITIVE PEAK VOLTAGE (V)	I_{DRM}/I_{RRM} , MAX. at T_J = $T_{J(Max.)}$ (mA)
D2300/...	02	200	300	100
D2300/...	04	400	500	
D2300/...	06	600	700	
D2300/...	08	800	900	
D2300/...	10	1000	1100	
D2300/...	12	1200	1300	
D2300/...	14	1400	1500	
D2300/...	16	1600	1700	

Standard Recovery Diodes

MAXIMUM ALLOWABLE RATINGS					
SYMBOL	DESCRIPTION	TEST CONDITIONS		VALUE	UNITS
$I_{F(AV)}$	Maximum average on-state current at heatsink temperature	180° conduction, half sine wave, double side cooled		2300	A
				125	°C
$I_{F(RMS)}$	Maximum RMS on-state current	DC at 25°C heatsink temperature, double side cooled		4420	A
I_{FSM}	Maximum peak, one-cycle non-repetitive surge current	t = 10 ms	100% V_{RRM} reapplied	Sinusoidal half wave, initial $T_J = T_J \text{ max.}$	kA
		t = 8.3 ms	reapplied		
		t = 10 ms	No voltage reapplied		
		t = 8.3 ms	reapplied		
I^2t	Maximum I^2t	t = 10 ms	100% V_{RRM} reapplied		kA ² s
		t = 8.3 ms	reapplied		
		t = 10 ms	No voltage reapplied		
		t = 8.3 ms	reapplied		
$I^2t^{1/2}$	Maximum $I^2t^{1/2}$	t = 0.1 to 10 ms, no voltage reapplied		58100	kA ² s ^{1/2}
$V_{F(TO)}$	Low level threshold voltage	(16.7% $\times \pi \times I_{F(AV)} < I < \pi \times I_{F(AV)}$), $T_J = T_J \text{ max.}$		0.786	V
r_F	Low level on-state slope resistance			0.100	mΩ
V_{FM}	Maximum on-state voltage	$I_{pk} = 7225A$, 50Hz half sine pulse, $T_J = T_J \text{ max.}$		1.53	V

THERMAL AND MECHANICAL SPECIFICATIONS				
SYMBOL	DESCRIPTION	TEST CONDITIONS	VALUE	UNITS
T_J	Maximum operating junction temperature	-	-40 to 180	°C
T_{Stg}	Maximum storage temperature	-	-40 to 180	
R_{thJ-hs}	Maximum thermal resistance, junction to heatsink	DC, double side cooled	0.023	°C/W
		180° sine wave, double side cooled	0.024	
		120° rectangular wave, double side cooled	0.025	
R_{thC-hs}	Maximum thermal resistance, case to heat-sink	Mtg. Surface smooth, flat, greased, double side cooled	0.01	
-	Mounting force, ± 10%	-	2500	kgf
-	Approximate weight	-	425	g
-	Case style	-	TO-200AD	JEDEC

Standard Recovery Diodes

CURRENT FORM FACTOR								
FORM FACTOR	CONDUCTION ANGLE	15°	30°	45°	60°	90°	120°	180°
Sine wave		31.956	15.832	10.452	7.721	4.933	3.527	2.468
Rectangular wave		24.000	12.000	8.000	6.000	4.000	3.000	2.000

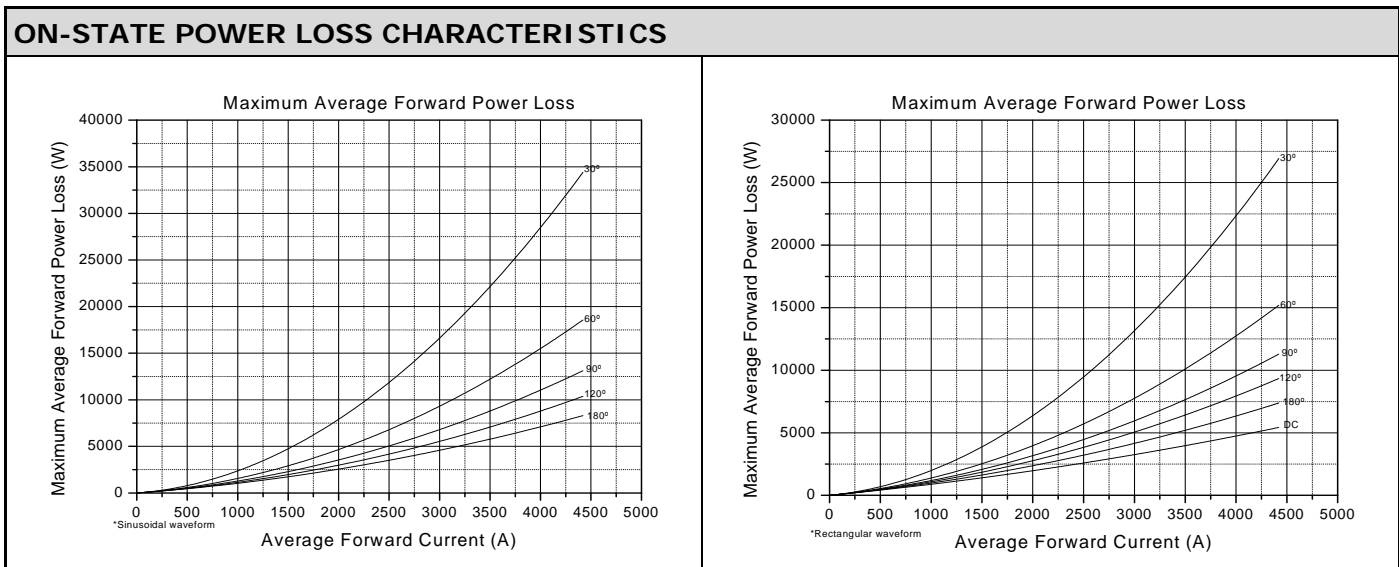
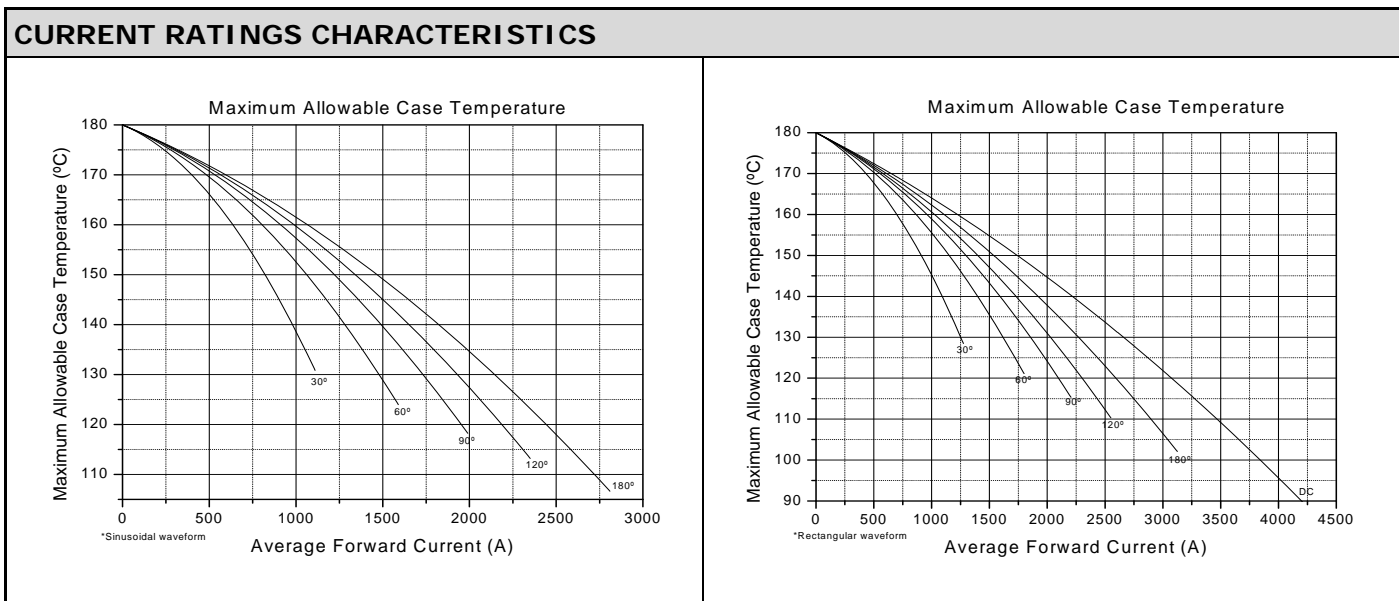

Standard Recovery Diodes

FORWARD VOLTAGE DROP / THERMAL IMPEDANCE CHARACTERISTICS

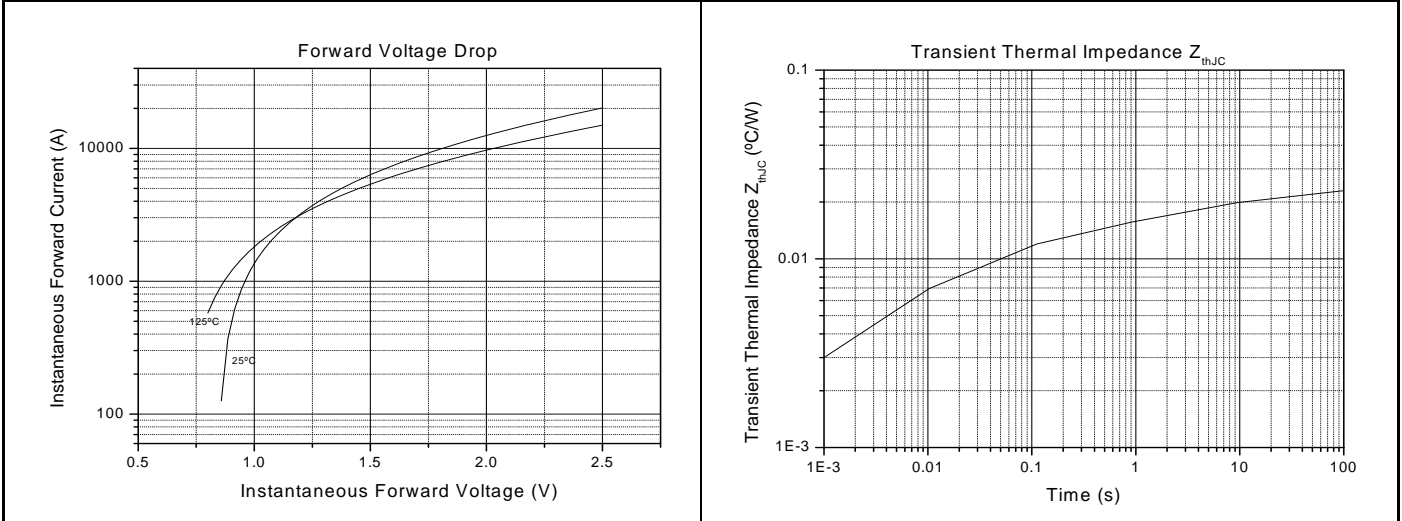

OUTLINE CHARACTERISTICS

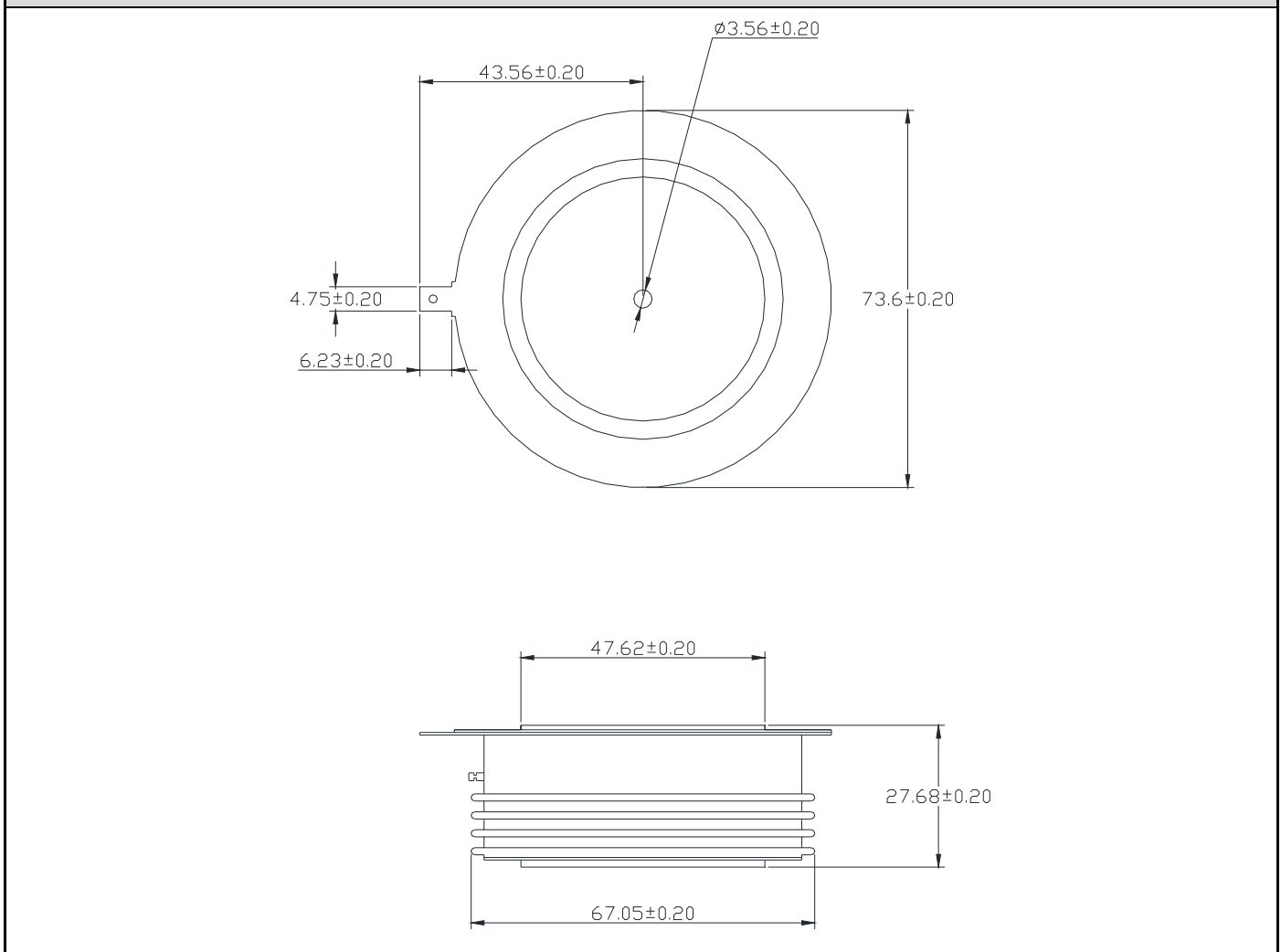

Standard Recovery Diodes

ORDERING INFORMATION

Device code

D	2300	/	16	-	-	-
①	②	③	④	⑤	⑥	⑦

- | | |
|---|--|
| 1 | <ul style="list-style-type: none"> - N = Phase Control Thyristors - F = Fast Thyristors (inverter grade) - D = Normal Recovery Diodes - DF = Fast Recovery Diodes - DD = Module (diode-diode) - DT = Module (diode-thyristor) - TD = Module (thyristor-diode) - TT = Module (thyristor-thyristor) - P = Press-fit diode |
| 2 | <ul style="list-style-type: none"> - Average Current Code |
| 3 | <ul style="list-style-type: none"> - Essential Part Number |
| 4 | <ul style="list-style-type: none"> - Voltage Code x 100 = V_{RRM} |
| 5 | <ul style="list-style-type: none"> - Turn-off time (fast thyristors only) - Reverse Recovery Time (fast diodes only) |
| 6 | <ul style="list-style-type: none"> - M = Metric Thread - I = Inch Thread |
| 7 | <ul style="list-style-type: none"> - None = Anode to stud (stud diodes only) - R = Cathode to stud (stud diodes only) |

Disclaimer

All product specifications and data are subject to change without notice.

Komkraft Ind.Com.de Componentes Eletrônicos Ltda., its affiliates, agents and employees, and all persons acting on its or their behalf (collectively, "Komkraft"), disclaim any and all liability for any errors, inaccuracies or incompleteness contained herein or in any other disclosure relating to any product.

Komkraft disclaims any and all liability arising of the use or application of any product described herein or of any information provided herein to the maximum extent permitted by law. The product specifications do not expand or otherwise modify Komkraft's terms and conditions of purchase, including but not limited to the warranty expressed therein, which apply to these products.

The products shown herein are not designed for use in medical, life-saving or life-sustaining applications unless otherwise expressly indicated.