

Standard Recovery Diodes

FEATURES

- High surge capability
- Qualified for industrial level
- International standard case DO-205AA
- Both metric and inch threads

TYPICAL APPLICATIONS

- Power supplies
- Machine tools control
- High power drives
- Welders
- Medium traction

MAJOR RATINGS AND CHARACTERISTICS			
PARAMETER	TEST CONDITIONS	VALUES	UNITS
$I_{F(AV)}$		100	A
	T_{Case}	125	°C
$I_{F(RMS)}$		200	A
	T_{Case}	125	°C
I_{FSM}	50 Hz	1710	A
	60 Hz	1880	A
I^2t	50 Hz	33	kA ² s
	60 Hz	35	kA ² s
V_{DRM}/V_{RRM}		200 to 1600	V
T_J		-40 to 180	°C

ELECTRICAL SPECIFICATIONS

VOLTAGE RATINGS				
SERIES	VOLTAGE CODE	V_{DRM}/V_{RRM} , MAX. RE- PETITIVE PEAK AND OFF-STATE VOLTAGE (V)	V_{RSM} , MAX. NON- REPETITIVE PEAK VOLTAGE (V)	I_{DRM}/I_{RRM} , MAX. at T_J = $T_{J(Max.)}$ (mA)
D100/...	02	200	300	15
D100/...	04	400	500	
D100/...	06	600	700	
D100/...	08	800	900	
D100/...	10	1000	1100	
D100/...	12	1200	1300	
D100/...	14	1330	1500	
D100/...	16	1520	1700	

Standard Recovery Diodes

MAXIMUM ALLOWABLE RATINGS						
SYMBOL	DESCRIPTION	TEST CONDITIONS			VALUE	UNITS
$I_{F(AV)}$	Maximum average on-state current at heatsink temperature	180° conduction, half sine wave			100	A
					125	°C
$I_{F(RMS)}$	Maximum RMS on-state current	DC at 25°C heatsink temperature			200	A
I_{FSM}	Maximum peak, one-cycle non-repetitive surge current	t = 10 ms	100% V_{RRM} reapplied	Sinusoidal half wave, initial $T_J = T_J$ max.	1.50	kA
		t = 8.3 ms			1.65	
		t = 10 ms	No voltage reapplied		1.71	
		t = 8.3 ms			1.88	
I^2t	Maximum I^2t	t = 10 ms	100% V_{RRM} reapplied		23	kA ² s
		t = 8.3 ms			25	
		t = 10 ms	No voltage reapplied		33	
		t = 8.3 ms			35	
$I^2t^{1/2}$	Maximum $I^2t^{1/2}$	t = 0.1 to 10 ms, no voltage reapplied			215	kA ² s ^{1/2}
$V_{F(TO)}$	Low level threshold voltage	(16.7% x π x $I_{F(AV)} < I < \pi$ x $I_{F(AV)}$), $T_J = T_J$ max.			0.85	V
r_F	Low level on-state slope resistance				1.80	mΩ
V_{FM}	Maximum on-state voltage	$I_{pk} = 314A$, 50Hz half sine pulse, $T_J = T_J$ max.			1.55	V

THERMAL AND MECHANICAL SPECIFICATIONS				
SYMBOL	DESCRIPTION	TEST CONDITIONS	VALUE	UNITS
T_J	Maximum operating junction temperature	-	-40 to 180	°C
T_{Stg}	Maximum storage temperature	-	-40 to 180	
R_{thJ-hs}	Maximum thermal resistance, junction to heatsink	DC	0.35	°C/W
		180° sine wave	0.40	
		120° rectangular wave	0.43	
R_{thC-hs}	Maximum thermal resistance, case to heat-sink	Mtg. Surface smooth, flat, greased	0.08	
-	Mounting force, ± 10%	-	10	N.m
-	Approximate weight	-	100	g
-	Case style	-	DO-205AA	JEDEC

CURRENT FORM FACTOR								
FORM FACTOR	CONDUCTION ANGLE	15°	30°	45°	60°	90°	120°	180°
		Sine wave		31.956	15.832	10.452	7.721	4.933
Rectangular wave		24.000	12.000	8.000	6.000	4.000	3.000	2.000

Standard Recovery Diodes

CURRENT RATINGS CHARACTERISTICS

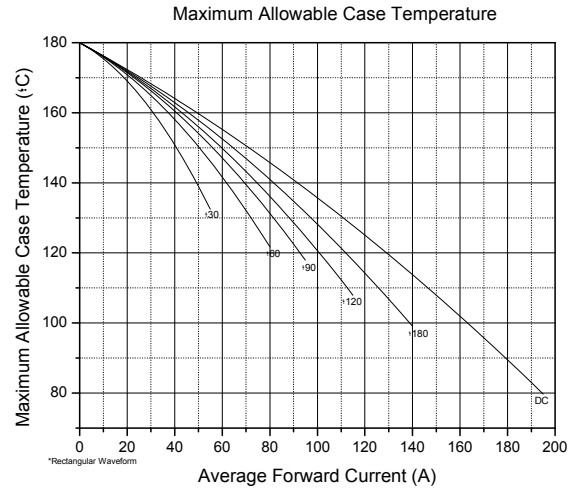
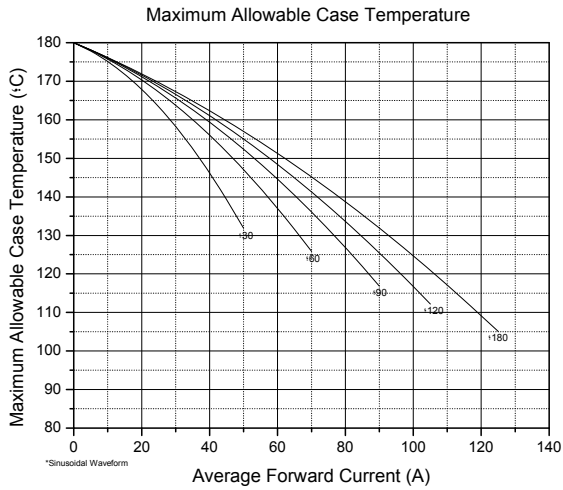

ON-STATE POWER LOSS CHARACTERISTICS

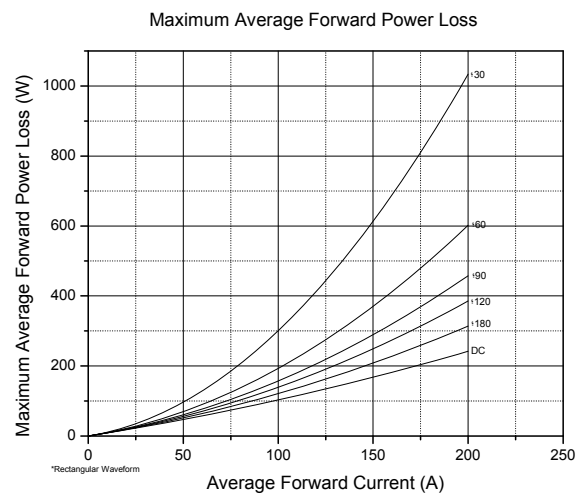
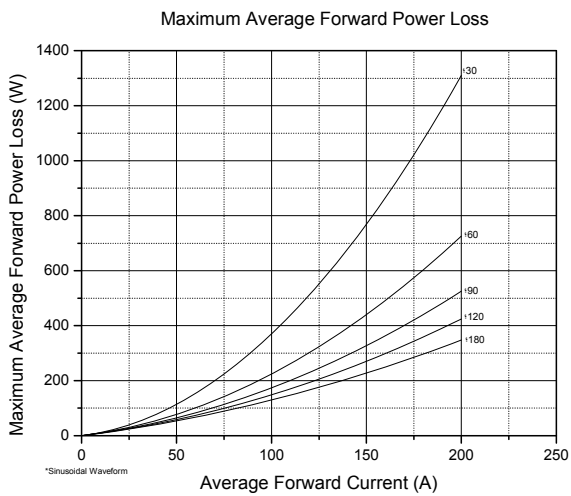

Standard Recovery Diodes

FORWARD VOLTAGE DROP / THERMAL IMPEDANCE CHARACTERISTICS

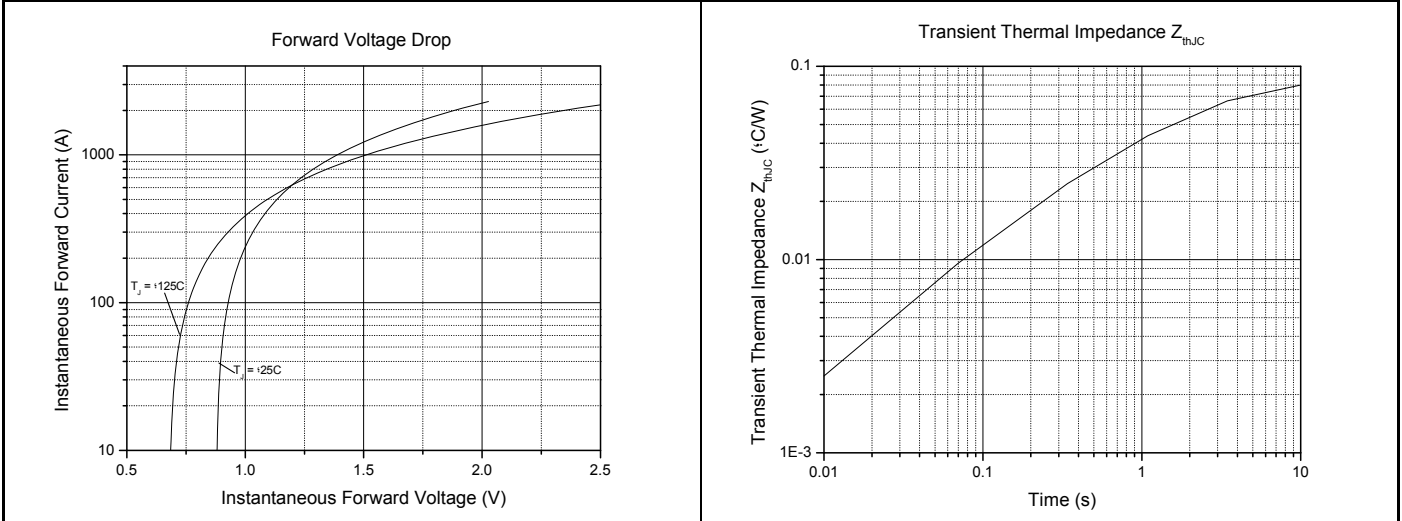

OUTLINE CHARACTERISTICS

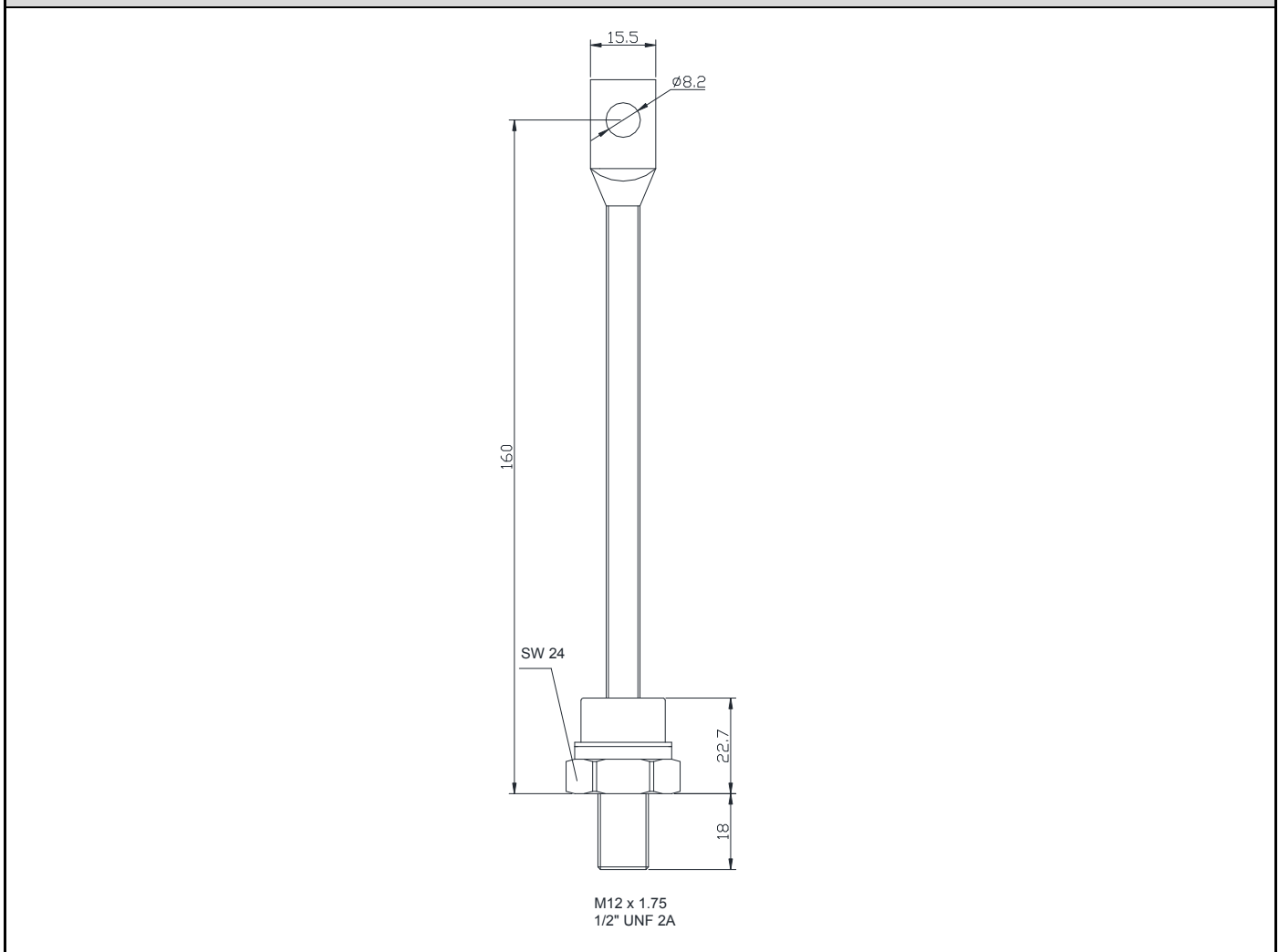

Standard Recovery Diodes

ORDERING INFORMATION

Device code

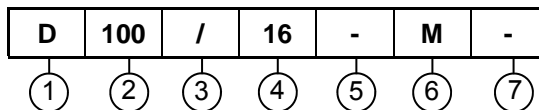

- | | |
|---|--|
| 1 | <ul style="list-style-type: none"> - N = Phase Control Thyristors - F = Fast Thyristors (inverter grade) - D = Normal Recovery Diodes - DF = Fast Recovery Diodes - DD = Module (diode-diode) - DT = Module (diode-thyristor) - TD = Module (thyristor-diode) - TT = Module (thyristor-thyristor) - P = Press-fit diode |
| 2 | - Average Current Code |
| 3 | - Essential Part Number |
| 4 | - Voltage Code x 100 = V_{RRM} |
| 5 | <ul style="list-style-type: none"> - Turn-off time (fast thyristors only) - Reverse Recovery Time (fast diodes only) |
| 6 | <ul style="list-style-type: none"> - M = Metric Thread - I = Inch Thread |
| 7 | <ul style="list-style-type: none"> - None = Anode to stud (stud diodes only) - R = Cathode to stud (stud diodes only) |

Disclaimer

All product specifications and data are subject to change without notice.

Komkraft Ind.Com.de Componentes Eletrônicos Ltda., its affiliates, agents and employees, and all persons acting on its or their behalf (collectively, "Komkraft"), disclaim any and all liability for any errors, inaccuracies or incompleteness contained herein or in any other disclosure relating to any product.

Komkraft disclaims any and all liability arising of the use or application of any product described herein or of any information provided herein to the maximum extent permitted by law. The product specifications do not expand or otherwise modify Komkraft's terms and conditions of purchase, including but not limited to the warranty expressed therein, which apply to these products.

The products shown herein are not designed for use in medical, life-saving or life-sustaining applications unless otherwise expressly indicated.