

FEATURES

- **HIGH POWER**
P1dB=33.0dBm at 7.1GHz to 8.5GHz
- **HIGH GAIN**
G1dB=22.0dB at 7.1GHz to 8.5GHz
- **BROAD BAND INTERNALLY MATCHED**
- **HERMETICALLY SEALED PACKAGE**

ABSOLUTE MAXIMUM RATINGS (Ta= 25°C)

CHARACTERISTICS	SYMBOL	UNIT	RATING
Drain Supply Voltage	VDD	V	15
Gate Supply Voltage	VGG	V	-10
Input Power	Pin	dBm	25
Flange Temperature	Tf	°C	-30 ~ +80
Storage Temperature	Tstg	°C	-65 ~ +175

RF PERFORMANCE SPECIFICATIONS (Ta= 25°C)

CHARACTERISTICS	SYMBOL	CONDITIONS	UNIT	MIN.	TYP.	MAX.
Output Power at 1dB Gain Compression Point	P1dB	VDD1=VDD2=VDD3 = 10V VGG= -5V f = 7.1 – 8.5GHz	dBm	32.0	33.0	—
Power Gain at 1dB Gain Compression Point	G1dB		dB	20.0	22.0	—
Drain Current*	IDD		A	—	1.7	2.0
Input VSWR	VSWRin		—	—	—	3.0

* IDD = IDD1 + IDD2 + IDD3

◆The information contained herein is presented only as a guide for the applications of our products. No responsibility is assumed by TOSHIBA for any infringements of patents or other rights of the third parties which may results from its use, No license is granted by implication or otherwise under any patent or patent rights of TOSHIBA or others.
 The information contained herein is subject to change without prior notice. It is therefor advisable to contact TOSHIBA before proceeding with design of equipment incorporating this product.

PACKAGE OUTLINE (2-11E1A)

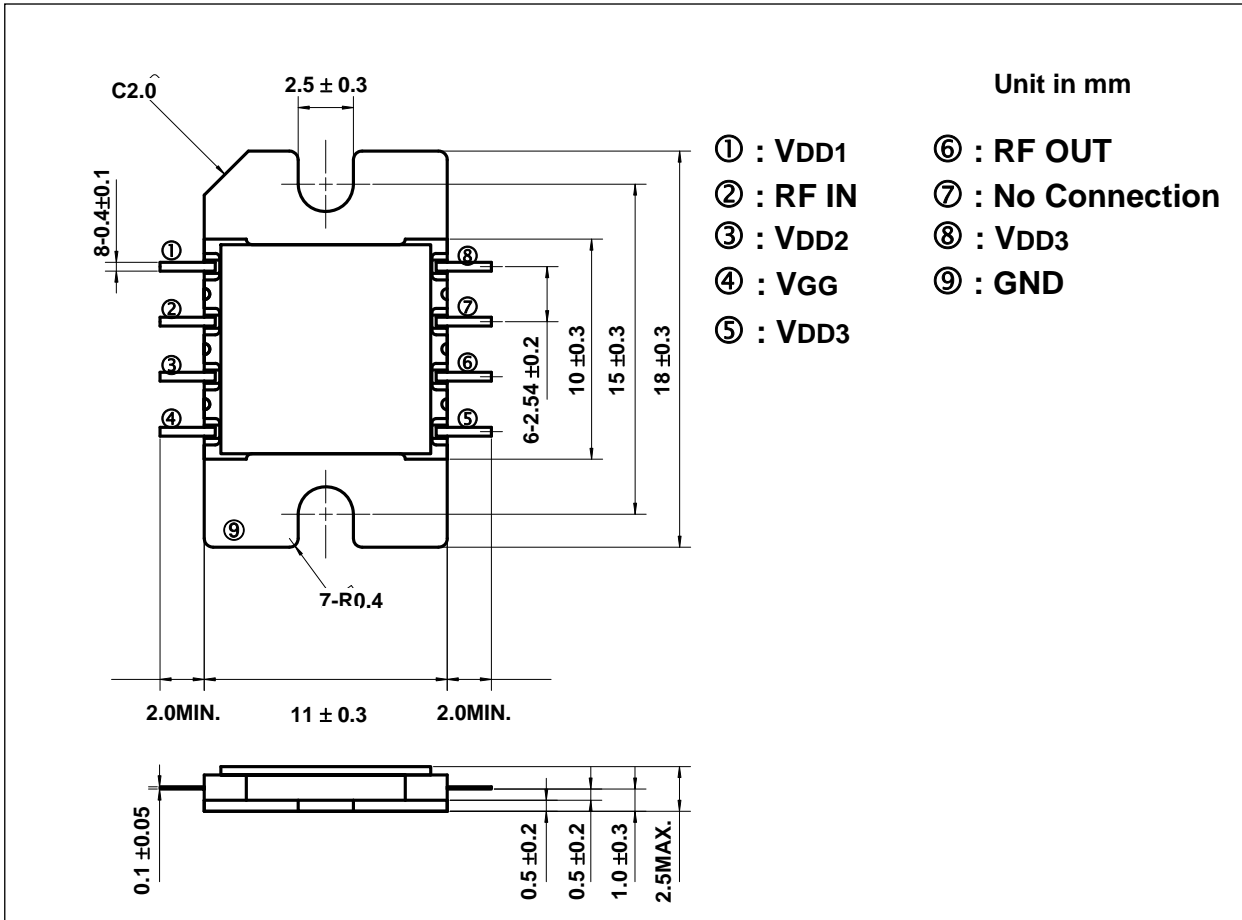

RECOMMENDED BIAS CONFIGURATION

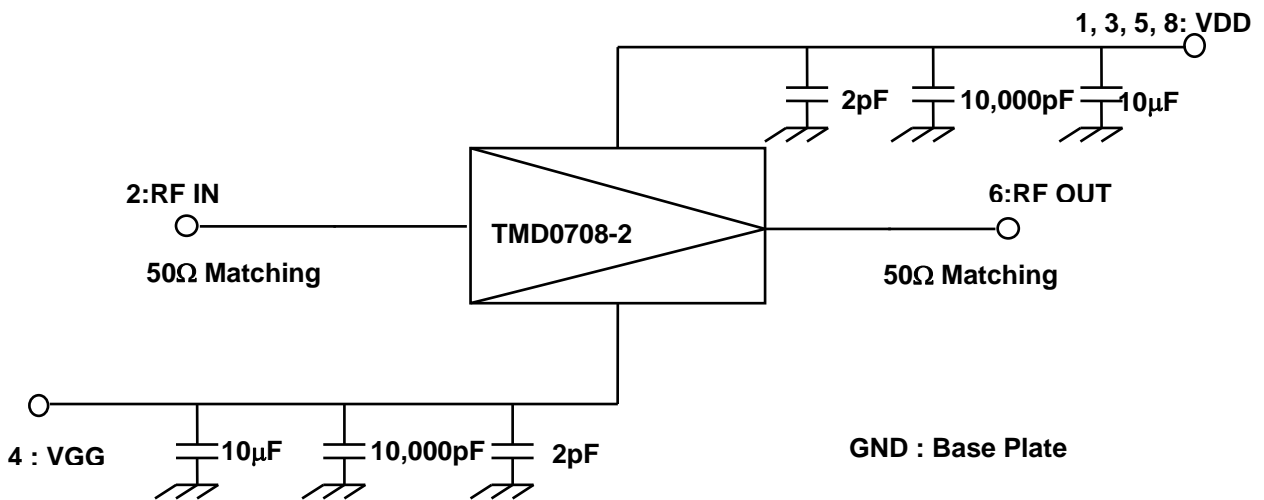

HANDLING PRECAUTIONS FOR PACKAGE MODEL

Soldering iron should be grounded and the operating time should not exceed 10 seconds at 260°C. Flanges of devices should be attached using screws and washers. Recommended torque is 0.18-0.20 N-m.