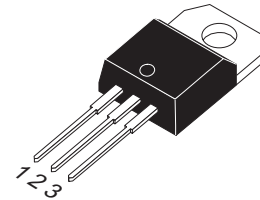
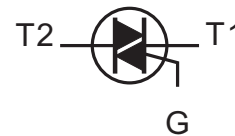

Simplified outline
TO-220AB

Symbol

Description

Glass passivated triacs in a plastic envelope, intended for use in applications requiring high bidirectional transient and blocking voltage capability and high thermal cycling performance. Typical applications include motor control, industrial and domestic lighting, heating and static switching.

Features

- Blocking voltage to 600 V
- On-state RMS current to 4 A

Applications

- Motor control
- Industrial and domestic lighting
- Heating
- Static switching

Pin	Description
1	Main terminal 1 (T1)
2	Main terminal 2 (T2)
3	gate (G)
TAB	Main terminal

SYMBOL	PARAMETER	Value	Unit
V_{DRM}	Repetitive peak off-state voltages	600	V
$I_T (RMS)$	RMS on-state current (360° conduction angle)	4	A
I_{TSM}	Non-repetitive peak on-state current (full cycle, T_j initial=25°C)	42	A

SYMBOL	PARAMETER	CONDITIONS	MIN	TYP	MAX	UNIT
$R_{th}(j-c)$	Junction to case(AC)		-	3.3	-	°C/W
$R_{th}(j-a)$	Junction to ambient		-	60	-	°C/W

Limiting values in accordance with the Maximum system(IEC 134)

SYMBOL	PARAMETER	CONDITIONS	MIN	Value	UNIT	
V_{DRM}	Repetitive peak off-state Voltages	$T_j=110^\circ\text{C}$	-	600	V	
$I_{T(RMS)}$	RMS on-state current	$T_c=90^\circ\text{C}$	-	4	A	
I_{TSM}	Non repetitive surge peak on-state current	T_j initial =25°C	$T_p=8.3\text{ms}$	-	42	A
			$T_p=10\text{ms}$	-	40	A
I^2t	I^2t value	$T_p=10\text{ms}$	-	8	A ² S	
di/dt	Critical rate of rise of on-state current Gate supply: $I_g=50\text{mA}$ $di_g/dt=0.1\text{A}/\mu\text{s}$		Repetitive $F=50\text{Hz}$	-	10	A/ μs
			Non repetitive	-	50	
I_{GM}		$t_p=20\mu\text{s}$	-	4	A	
I_{DRM}	$V_{DRM}=V_{RRM}$	$T_j=25^\circ\text{C}$	-	0.01	mA	
I_{RRM}	$V_{DRM}=V_{RRM}$	$T_j=110^\circ\text{C}$	-	0.75	mA	
$P_{G(AV)}$	Average gate power		-	1	W	
T_{stg}	Storage temperature range		-40	150	°C	
T_j	Operating junction Temperature range		-40	110	°C	

 $T_j = 25^\circ\text{C}$ unless otherwise stated

SYMBOL	PARAMETER	CONDITIONS	MIN	TYP	MAX	UNIT	
Static characteristics							
I_{GT}		$V_D=12\text{V(DC)}$; $R_L=33\Omega$	I-II-III	-	-	5	mA
			IV	-	-	10	mA
I_L		$I_g=1.2 I_{GT}$	I-III-IV	-	10	-	mA
			II	-	20	-	mA
I_H		$I_T=100\text{mA}$ gate open	-	-	15	mA	
V_{GT}		$V_D=12\text{V(DC)}$; $R_L=33\Omega$			1.5	V	
V_{GD}		$V_D=V_{DRM}$ $R_L=3.3\text{K}\Omega$ $T_j=110^\circ\text{C}$	0.2	-	-	V	
dV/dt		Linear slope up to $V_D=67\%V_{DRM}$ gate open; $T_j=110^\circ\text{C}$	-	10	-	V/ μs	
$(di/dt)_c$	$(di/dt)_c=1.8\text{A/ms}$	$T_j=110^\circ\text{C}$	-	1	-	V/ μs	

Dynamic Characteristics

V_{TM}	$I_{TM}=5.5\text{A}$ $t_p=380\mu\text{s}$	$T_j=25^\circ\text{C}$	-	-	1.65	V
t_{gt}	$V_D=V_{DRM}$ $I_g=40\text{mA}$ $di_g/dt=0.5\text{A}/\mu\text{s}$	$T_j=25^\circ\text{C}$ I-II-III-IV	-	2	-	μs

Description

Fig. 1: Maximum RMS power dissipation versus RMS on-state current ($F = 50\text{Hz}$). (Curves are cut off by $(di/dt)_c$ limitation)

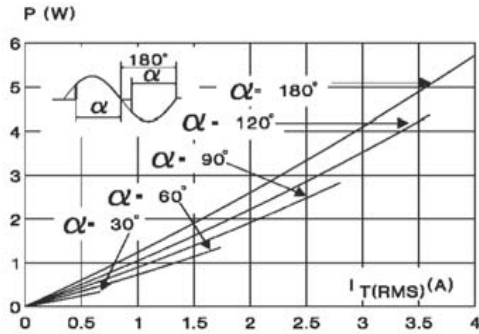

Fig. 2: Correlation between maximum RMS power dissipation and maximum allowable temperature (T_{amb} and T_{case}) for different thermal resistances heatsink + contact (BTA).

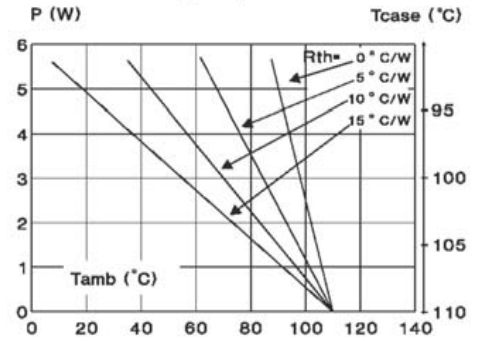

Fig. 3: Correlation between maximum RMS power dissipation and maximum allowable temperature (T_{amb} and T_{case}) for different thermal resistances heatsink + contact (BTB).

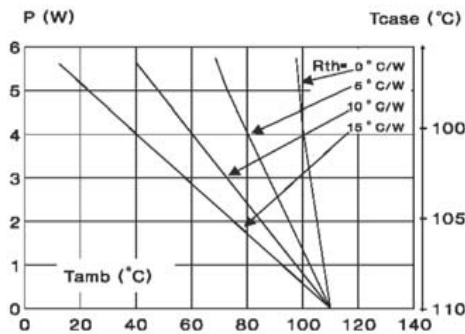

Fig. 4: RMS on-state current versus case temperature.

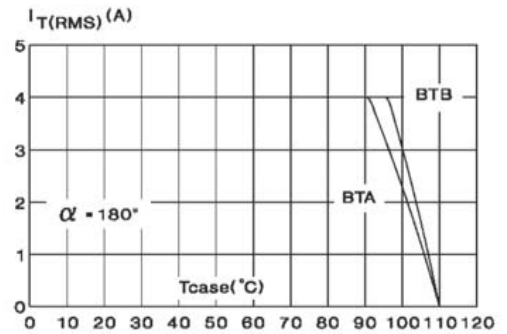

Fig. 5: Relative variation of thermal impedance versus pulse duration.

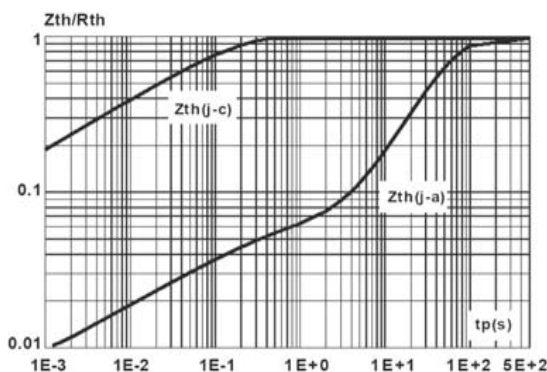
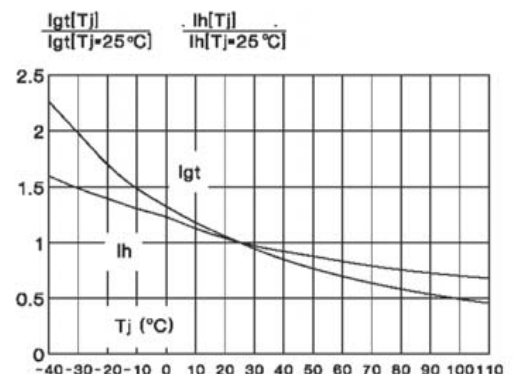
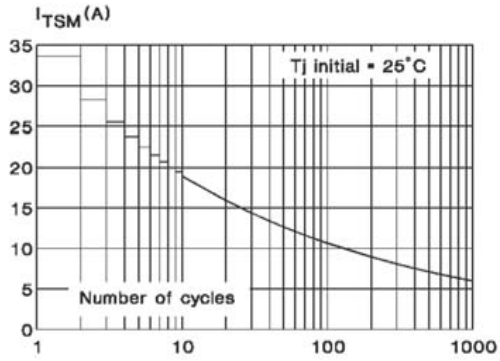
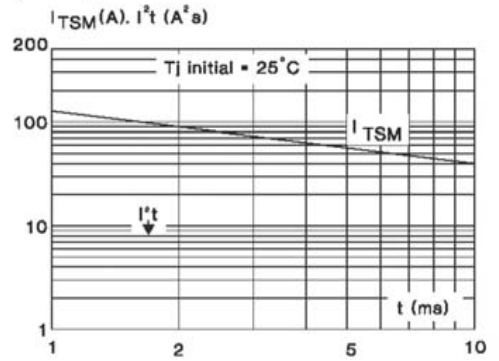
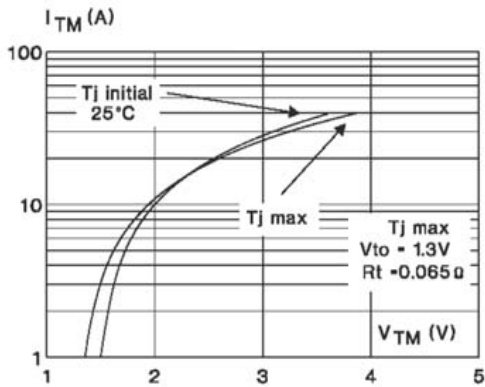
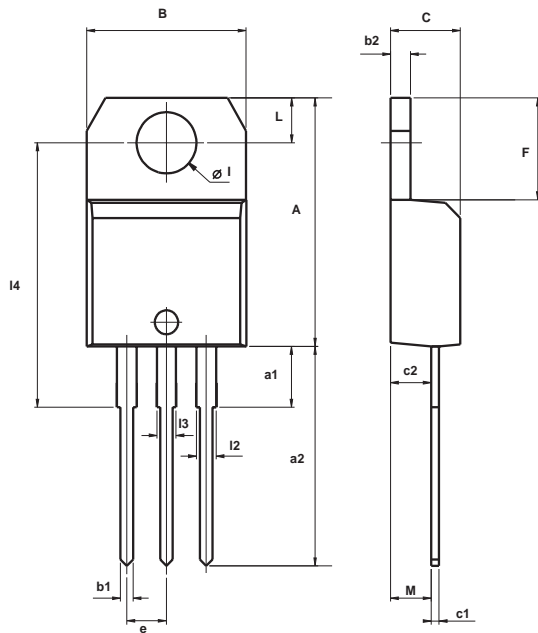

Fig. 6: Relative variation of gate trigger current and holding current versus junction temperature.



Description
Fig. 7: Non repetitive surge peak on-state current versus number of cycles.

Fig. 8: Non repetitive surge peak on-state current for a sinusoidal pulse with width: $t \leq 10\text{ms}$, and corresponding value of I^2t .

Fig. 9: On-state characteristics (maximum values).

Package Mechanical Data
TO-220AB (Plastic)

REF.	DIMENSIONS					
	Millimeters			Inches		
	Min.	Typ.	Max.	Min.	Typ.	Max.
A	15.20		15.90	0.598		0.625
a1		3.75			0.147	
a2	13.00		14.00	0.511		0.551
B	10.00		10.40	0.393		0.409
b1	0.61		0.88	0.024		0.034
b2	1.23		1.32	0.048		0.051
C	4.40		4.60	0.173		0.181
c1	0.49		0.70	0.019		0.027
c2	2.40		2.72	0.094		0.107
e	2.40		2.70	0.094		0.106
F	6.20		6.60	0.244		0.259
I	3.75		3.85	0.147		0.151
I4	15.80	16.40	16.80	0.622	0.646	0.661
L	2.65		2.95	0.104		0.116
I2	1.14		1.70	0.044		0.066
I3	1.14		1.70	0.044		0.066
M		2.60			0.102	