

S8050G TRANSISTOR (NPN)

Features

Power dissipation

$$P_{CM} : 0.625 \text{ W (} T_{amb}=25 \text{)}$$

Collector current

$$I_{CM} : 0.5 \text{ A}$$

Collector-base voltage

$$V_{(BR)CBO} : 40 \text{ V}$$

Operating and storage junction temperature range

$$T_J, T_{stg} : -55 \text{ to } +150$$

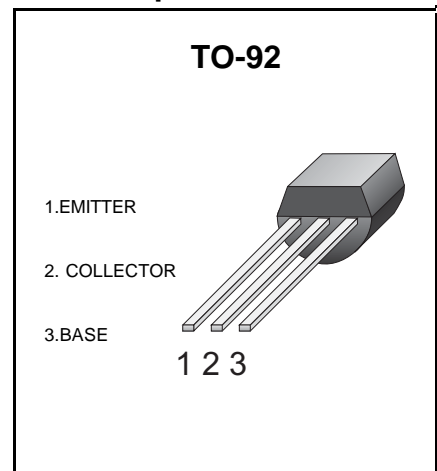
Simplified outline

Electrical Characteristics ($T_{amb}=25$ unless otherwise specified)

Parameter	Symbol	Test conditions	MIN	TYP	MAX	UNIT
Collector-base breakdown voltage	$V_{(BR)CBO}$	$I_C=100 \mu A, I_E=0$	40			V
Collector-emitter breakdown voltage	$V_{(BR)CEO}$	$I_C=1 \text{ mA}, I_B=0$	25			V
Emitter-base breakdown voltage	$V_{(BR)EBO}$	$I_E=100 \mu A, I_C=0$	5			V
Collector cut-off current	I_{CBO}	$V_{CB}=40 \text{ V}, I_E=0$			0.1	μA
Collector cut-off current	I_{CEO}	$V_{CE}=20 \text{ V}, I_B=0$			0.1	μA
Emitter cut-off current	I_{EBO}	$V_{EB}=3 \text{ V}, I_C=0$			0.1	μA
DC current gain	$h_{FE(1)}$	$V_{CE}=1 \text{ V}, I_C=50 \text{ mA}$	85		300	
	$h_{FE(2)}$	$V_{CE}=1 \text{ V}, I_C=500 \text{ mA}$	50			
Collector-emitter saturation voltage	$V_{CE(sat)}$	$I_C=500 \text{ mA}, I_B=50 \text{ mA}$			0.6	V
Base-emitter saturation voltage	$V_{BE(sat)}$	$I_C=500 \text{ mA}, I_B=50 \text{ mA}$			1.2	V
Transition frequency	f_T	$V_{CE}=6 \text{ V}, I_C=20 \text{ mA}$ $f=30 \text{ MHz}$	150			MHz

Classification Of $h_{FE(1)}$

Rank	B	C	D
Range	85-160	120-200	160-300

Mechanical Data

Dimensions in mm

Net Mass:0.2 g

TO-92

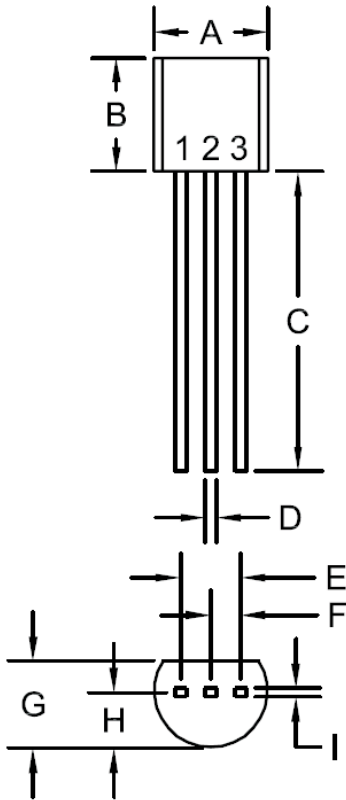

DIMENSIONS				
SYMBOL	INCHES		MILLIMETERS	
	MIN	MAX	MIN	MAX
A (DIA)	0.175	0.205	4.45	5.21
B	0.170	0.210	4.32	5.33
C	0.500	-	12.70	-
D	0.016	0.022	0.41	0.56
E	0.100		2.54	
F	0.050		1.27	
G	0.125	0.165	3.18	4.19
H	0.080	0.105	2.03	2.67
I	0.015		0.38	